

rotameters

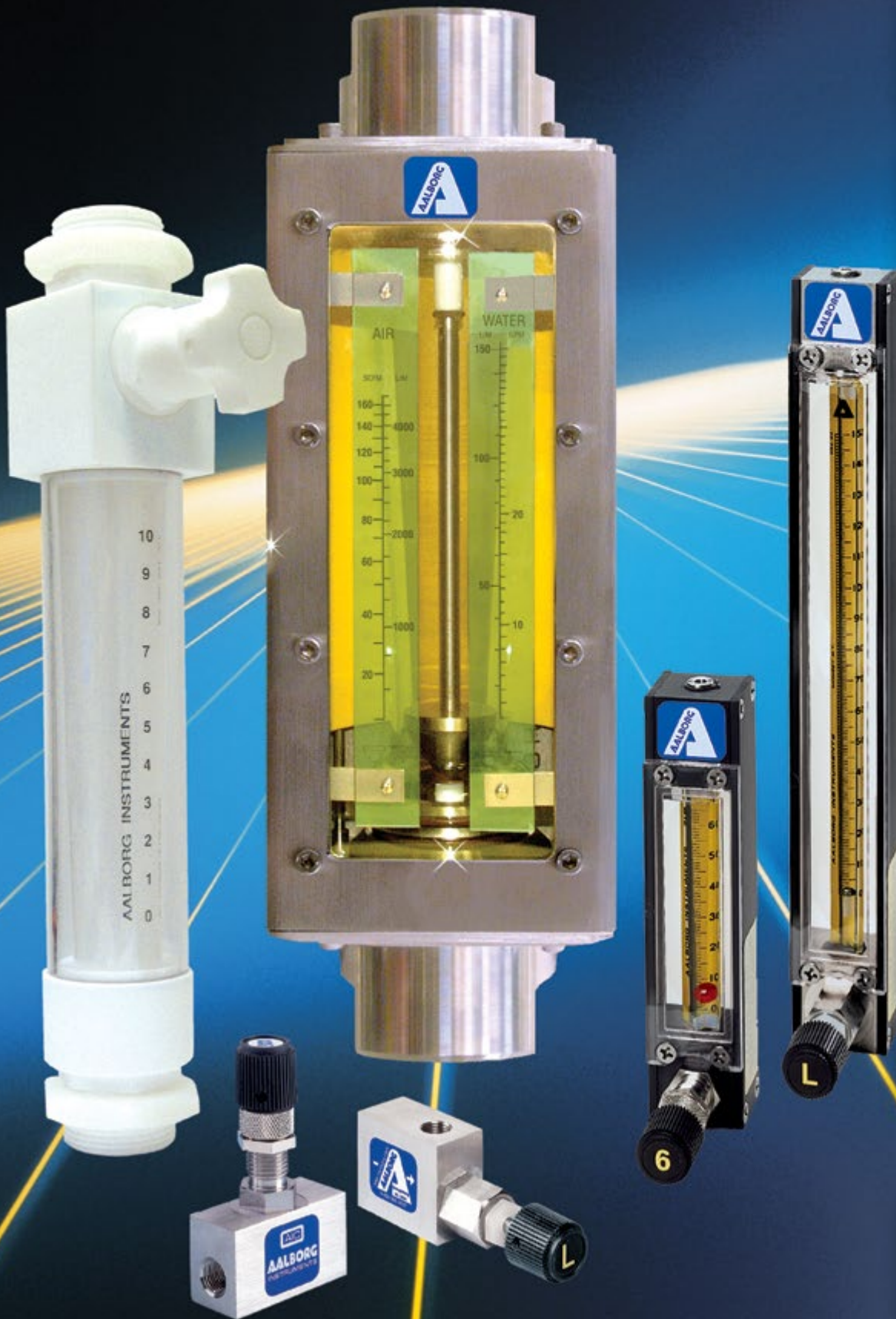

AALBORG



Worldwide Distribution

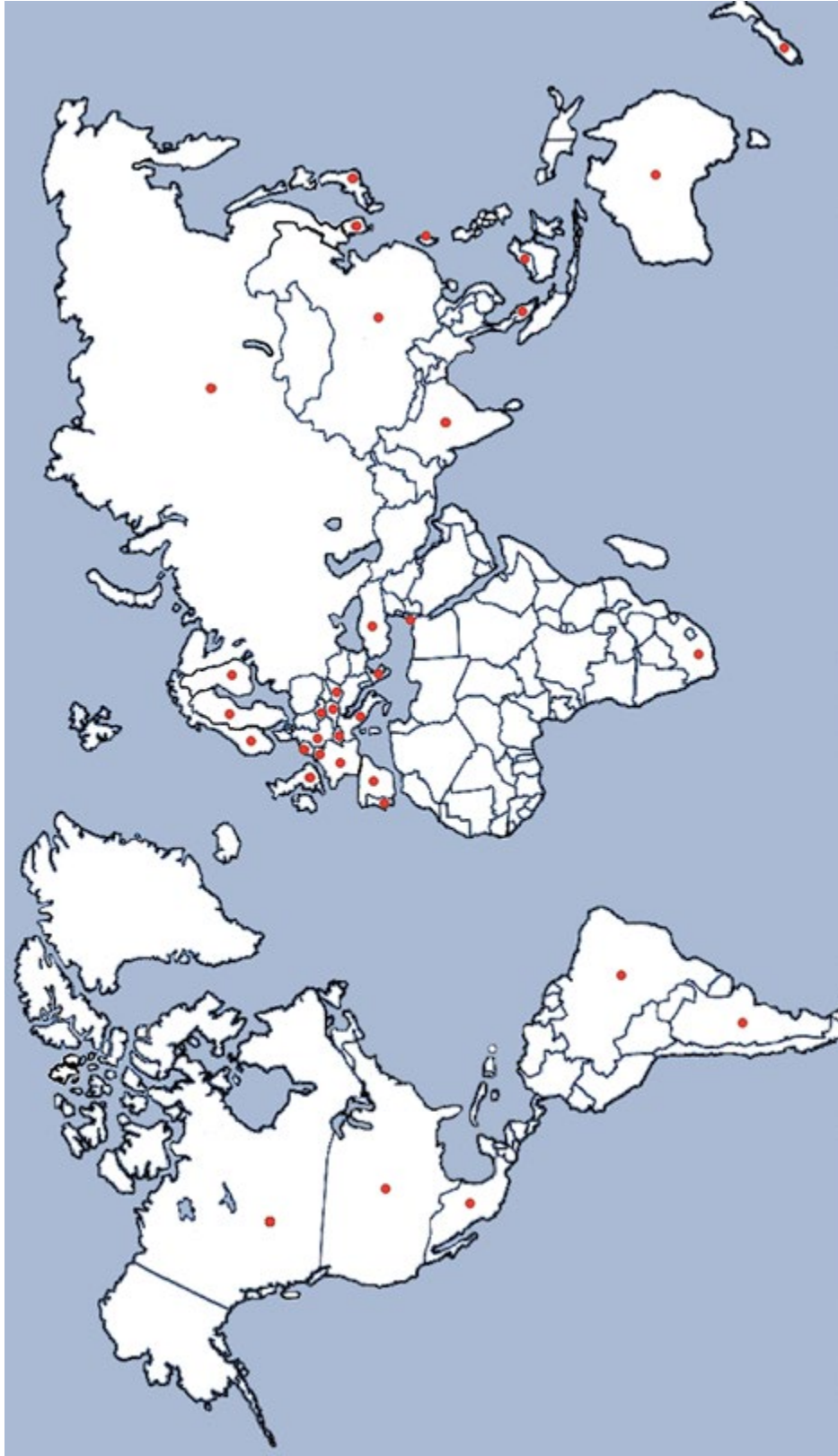

Visit our web site at: www.aalborg.com



About the Company	<p>Founded in 1972, AALBORG® is well-known throughout the world as a primary manufacturer of precision instrumentation for flow measurement and control.</p> <p>We operate two divisions:</p> <p>The Variable Area Division manufactures a complete line of glass tube rotameters. These flow meters are available with aluminum, brass, stainless steel or PTFE wetted components. AALBORG® also manufactures a unique line of PFA tube meters for ultrapure or corrosive applications. Precision barstock stainless steel or brass needle valves, as well as PTFE valves, are also manufactured in this division.</p> <p>The Electronics Division produces analog and digital mass flow meters and controllers, as well as a diverse line of wafer and insertion type vortex flow meters for steam, liquid or gases. In addition a line of peristaltic pumps, stepping motor driven valves made in this department are highly useful in processing and OEM applications.</p>
NIST Traceability	<p>All equipment used for flow calibrations are traceable to NIST.</p>
Accredited Calibration Services	<p>AALFA-KAL Metrology Laboratory, division of Aalborg Instruments & Controls is accredited by A2LA in conformance to ISO17025/2005 and to Z540-1/1994. Gas flow calibrations up to 50L/min are performed according Scope of Accreditation - Certificate Number: 3989.01.</p>
Technical Assistance	<p>Technical Assistance is readily available. Customers are invited to contact the company or our distributors to discuss individual requirements. OEM applications are welcome.</p>
ISO9001/2015 Certification	<p>Aalborg® has been ISO 9001 certified since April of 1995. We are very proud of the design features and the exceptionally high quality for which our products which have been known since 1972. It is our policy that through strict enforcement of exacting manufacturing standards the Aalborg® brand name continues to be associated with a reputation of high quality and reliability. Our products are backed by meticulous innovative engineering combined with efficient manufacturing practices and a highly skilled work force guaranteeing total customer satisfaction.</p>
Our Mission	<p>It is the policy of AALBORG® to develop, produce and deliver products and services which consistently conform to or exceed customer requirements.</p> <p>Our commitment is to provide cutting-edge technology combined with a sincere desire to serve our customers and produce the highest quality products attainable.</p>

TABLE OF CONTENTS

Principle of Operation /General Description /Flow Tubes & Valves

Pages 1-3

CAL

Calibrations, Services and Certificates

Pages 4-16

P Px

Single & Multiple Tube Flow Meters

Pages 17-21



T Tx

PTFE-Glass Single and Multiple Tube Flow Meters

Pages 22-26



S

S Style Single Tube Flow Meters

Pages 27-29



O

Optical Sensor Switch

Pages 30-36



G

Gas Proportioners

Pages 37-39

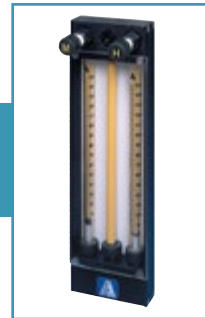

K

Kits

Pages 40



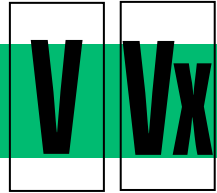

**Medium Range Brass, Stainless, PTFE
and Direct Reader Flow Meters**



Pages 41-45



Stainless Industrial Flow Meters



Pages 46-47



In Line PTFE Flow Meter



Pages 48-50



PTFE-PFA Flow Meters



Pages 51-52



Barstock Valves



Pages 53-55



PTFE Needle Valves



Pages 56-58

TECHNICAL INFORMATION

Spare Valve Cartridge Flow Capacities	Page 59
Meter Sizing and Calculation vs Calibration	Pages 60-61
Tables of Standard Flow Capabilities	Pages 62-64
Table of Flow Capacities For Gas	Page 65
Direct Reading Scales	Pages 66-68
Conversion Factors	Page 69

TRADEMARKS

Aalborg® - is a registered trademark of Aalborg Instruments, Inc.
 Buna® - is a registered trademark of DuPont Dow Elastomers.
 Carboloy® - is a registered trademark of General Electric Company.
 Lexan® - is a registered trademark of General Electric Company.
 Kalrez® - is a registered trademark of DuPont Dow Elastomers.
 Kynar® - is a registered trademark of Atochem North America, Inc.
 Viton® - is a registered trademark of The Chemours Company.

Aalborg® reserves the right to change all designs and dimensions without notice.

For certified dimensions please contact Aalborg® Instruments and Controls.

PRINCIPLE OF OPERATION

When compared with other types of flow instrumentation, variable area interchangeable flow meters offer the most practical, precise and economical means of visually indicating flow rate measurement.

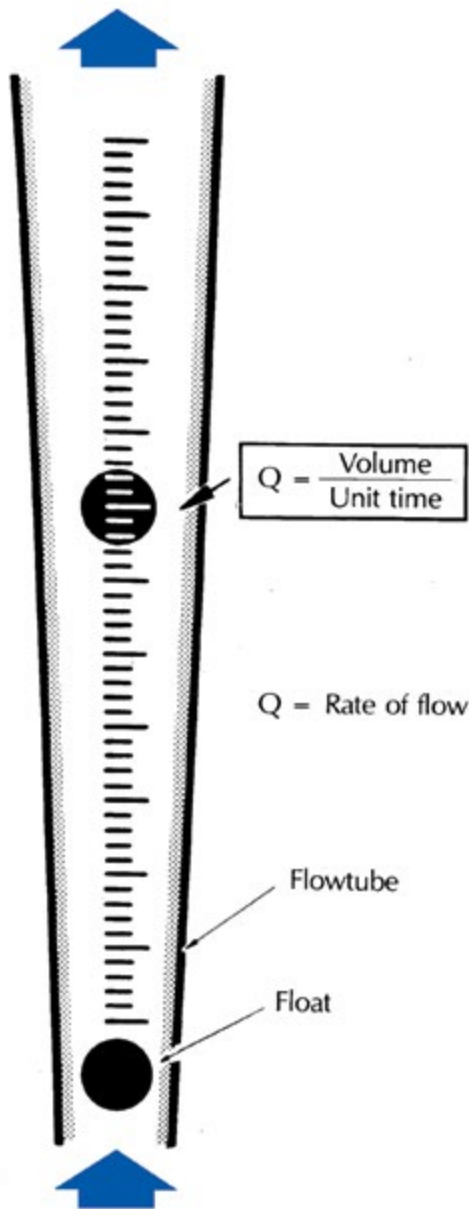

They require no electrical connections, and have low meter related pressure drops.

Meters are available in a large selection of flow rates and configurations, to accommodate the unique requirements of most applications.

Included in the line are flow tube assemblies, single and multiple tube flow meters. PTFE-Glass meters are for metering corrosive fluids or for high purity requirements.

Back pressure compensated Gas Proportioners are popular choices for blending component gases accurately to customized end use requirements at great savings.

Multiple tube flow meters are available with or without manifolding.

A tapered glass FLOW TUBE, and a spherical FLOAT inside it, constitute the heart of variable area type flow meters.

Flow meters are installed vertically in lines carrying gases or liquids to be monitored.

Fluids enter through the smaller opening at the bottom, and exit through the upper end. Upward pressure causes the float to rise. Flow takes place through the circular area between the float and the inside surface of the flow tube. As the float rises, the flow area increases, due to the tapered bore of the flow tube.

Dynamic equilibrium results when the buoyant force, due to the float and the upward force, due to fluid pressure, balance the weight of the float.

The vertical position of the float at equilibrium corresponds exclusively to one particular flow rate.

This flow rate is obtained by determining the height of the float with the aid of a scale etched on the flow tube.

These meters have the highest useful flow ranges providing consistently reliable readings from maximum flow down to 5 to 10% of capacity.

INTERCHANGEABILITY

Flow tubes and other components are thoroughly interchangeable resulting in greatly increased versatility. Meters are even interchangeable with standard sizes made by other manufacturers.

As a result of simple assembly and installation procedures, it is possible to use several sets of flow tubes in conjunction with one mounting frame.

flow tubes

- ✓ Precision fabricated from heavy walled, shock resistant borosilicate glass.
- ✓ Bores are uniformly tapered or formed with internal "rib-guides" or flutes.
- ✓ Floats are retained by TFE plugs.
- ✓ OPTIGRAD™ scales minimize parallax and eye fatigue.
- ✓ Interchangeability.
- ✓ Self cleaning.
- ✓ Low differential pressures that stay independent of Flow rate changes.

OPTIGRAD™ SCALES

The vertical "tangential locator line" facilitates hair-line accuracy and convenience of reading. Flow tubes are supplied with millimeter, or direct reading scales.

Standard scale lengths are 65 mm (2.56 in) or 150mm (5.91 in). Flow rates are determined by lining up the scale graduation at the center of the spherical float.

Parallax and lack of visual reference will affect the accuracy and reproducibility of metering to a great extent. Such a drawback is eliminated by OPTIGRAD™ scales.

A vertical "locator" line is incorporated into the geometry of the scale graduation. To pinpoint the center of the float with "hairline" accuracy.

readings are taken as follows:

- 1) Position head in front of flow meter, with eyes at level with the float.
- 2) Move head horizontally to the left until the contour of the float appears to just touch the "locator" line tangentially.
- 3) The intersection of the "locator" line with the horizontal graduation at the center of the float, pinpoints the appropriate reading value.

UNIVERSAL MILLIMETER SCALES

Millimeter scales indicate the height to which the float rises within the metering

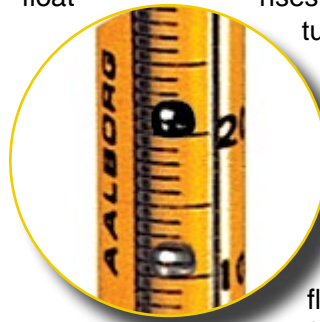

tube and are correlated with specific flow rates through the use of appropriate calibration data sheets or curves.

Scales of this type permit utilization of a given flow meter for a great number of different fluids at diverse pressure and temperature conditions. See tables 6,7,8, 9 and 10 on pages 61-64 for maximum flow rates.

To minimize eye fatigue associated with periods of repetitive readings, contrasting yellow backgrounds are provided behind scales

DIRECT READING SCALES

Direct reading scales are indicating flow rates, in engineering units such as [mL/min], standard cubic feet per hour [scfh]

etc. Such scales are designed exclusively for a specific gas or liquid at a given set of pressure and temperature and are valid for the associated units of flow only.

Thus, the convenience of direct reading scale designs should be weighed against the resultant limitations of applicability.

For listing of flow tubes with standard Direct Reading Scales, see tables 11-22 on pages 65 thru 67.



BUILT-IN VALVES

Meters are available with built-in needle valves (CV™), high precision metering valves (MFV™) with “non-rising stems”, or with no valves.

Built-in valves are mounted at the inlet (bottom) or outlet (top) of flow meters. Generally, for gas metering it is recommended that valves are positioned at inlets - for liquids valves may be positioned either at inlets or outlets. For vacuum service, valves must be mounted at outlets.

If unspecified at the time of ordering, meters will be shipped with valves mounted at the inlets.

HIGH PRECISION VALVES (MFV™)

The higher cost of MFV™ valves is justified whenever high sensitivity control and resolution are desirable particularly in conjunction with metering tubes of very low flow rates. A choice of six MFV™ flow capacities are offered (see Table 1 on page 58) to be matched with individual flow meter ranges.

This unique design comprises rectilinear motion valve needles, with non-rising stems. As the needle advances into and out of high precision cylindrical orifices, the flat tapered surface of the needle gradually, without turning, uncovers the flow area.



MFV™ Valve Cartridge

CV™ VALVE CARTRIDGES

These valves are designed for adjusting flow rates in applications where high resolution metering regulation is not essential. Available in three ranges, (see Table 2 on page 58) they represent a relatively inexpensive option.

The simple construction of CV™ valves incorporate a VALVE SPINDLE with conical ends and compound angles for optimal resolution.

The VALVE NEEDLE turns as it travels into or out of the VALVE ORIFICE. In conjunction with the cylindrical cross section, the conical front tip of the VALVE SPINDLE increases or decreases the annular flow area. The cartridge serves as a bubble-tight “shut-off” valve when the tip of the VALVE SPINDLE comes into a stop position against the VALVE ORIFICE.



CV™ Valve Cartridge

to reverse the position of valves

- 1) Disassemble flow tubes from frames.
- 2) Install flow tubes upside down in frame.
- 3) Invert flow meter.

FRONT SHIELDS WITH MAGNIFIER LENSES

A unique longitudinal magnifier is part of the molded Lexan® front shield which is supplied on all single tube flow meters.

The magnification of the scale reading facilitates greatly enhanced resolution of measurement.



MOUNTINGS

Flow meters are shipped ready for panel mounting. Meters may be mounted on or behind panels.

For “on-panel” installations holes are drilled for inlet and outlet fittings and meters are mounted simply by means of panel mounting nuts supplied.

Mounting behind panels is done by utilizing the screws from front shields. Panel mounting is easily converted to self standing bench mounting by using the appropriate optional acrylic tripod base.

NIST TRACEABLE CALIBRATIONS

Our laboratories are fully equipped to perform NIST traceable flow calibrations for Rotameters, Mass Flow Meters and Mass Flow Controllers.

We offer calibration services on meters and controllers of other manufacturers' products as well.

AALFA-KAL laboratory is equipped to calibrate Molboxes. Our technicians are trained and certified by the manufacturer of Molboxes and Moblocs.

For fast cost effective service please contact our customer service department.

A2LA ACCREDITED CALIBRATIONS

AALFA-KAL Metrology Laboratory, division of Aalborg Instruments & Controls is accredited by A2LA in conformance to ISO17025/2005 and to Z540-1/1994. Gas flow calibrations up to 50L/min are performed according to Scope of Accreditation - Certificate Number: 3989.01.

COMPLIANCE QUALIFICATIONS

Extensive set of Molbox/Molblocs ensure conveniently overlapping calibration ranges.

- ✓ ANSI/NCSL Z540-1-1994
- ✓ ISO9001/2015 CERTIFIED
- ✓ MIL-STD-456624A
- ✓ ISO17025 Accredited

Partial view of the gas calibration laboratory.



Technicians calibrating Flow Controllers using Bell Provers and Molbox/Molblocs technology.



Customer's Rotameter returned for re-calibration performed in Aalborg's laboratory.

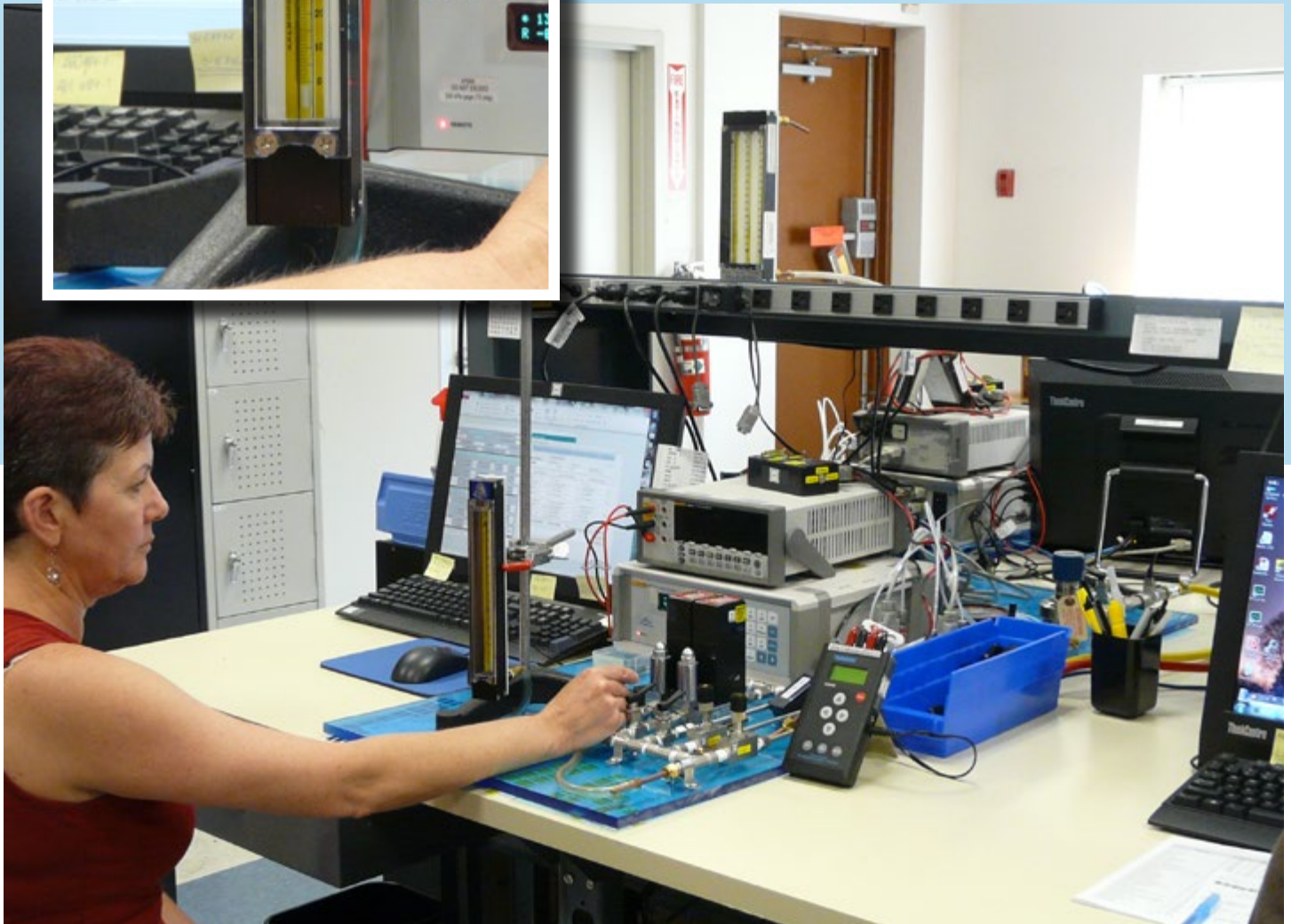



Close-up view of Molbox/Molblocs equipment supported by COMPASS software for calibrating GFM flow meters.

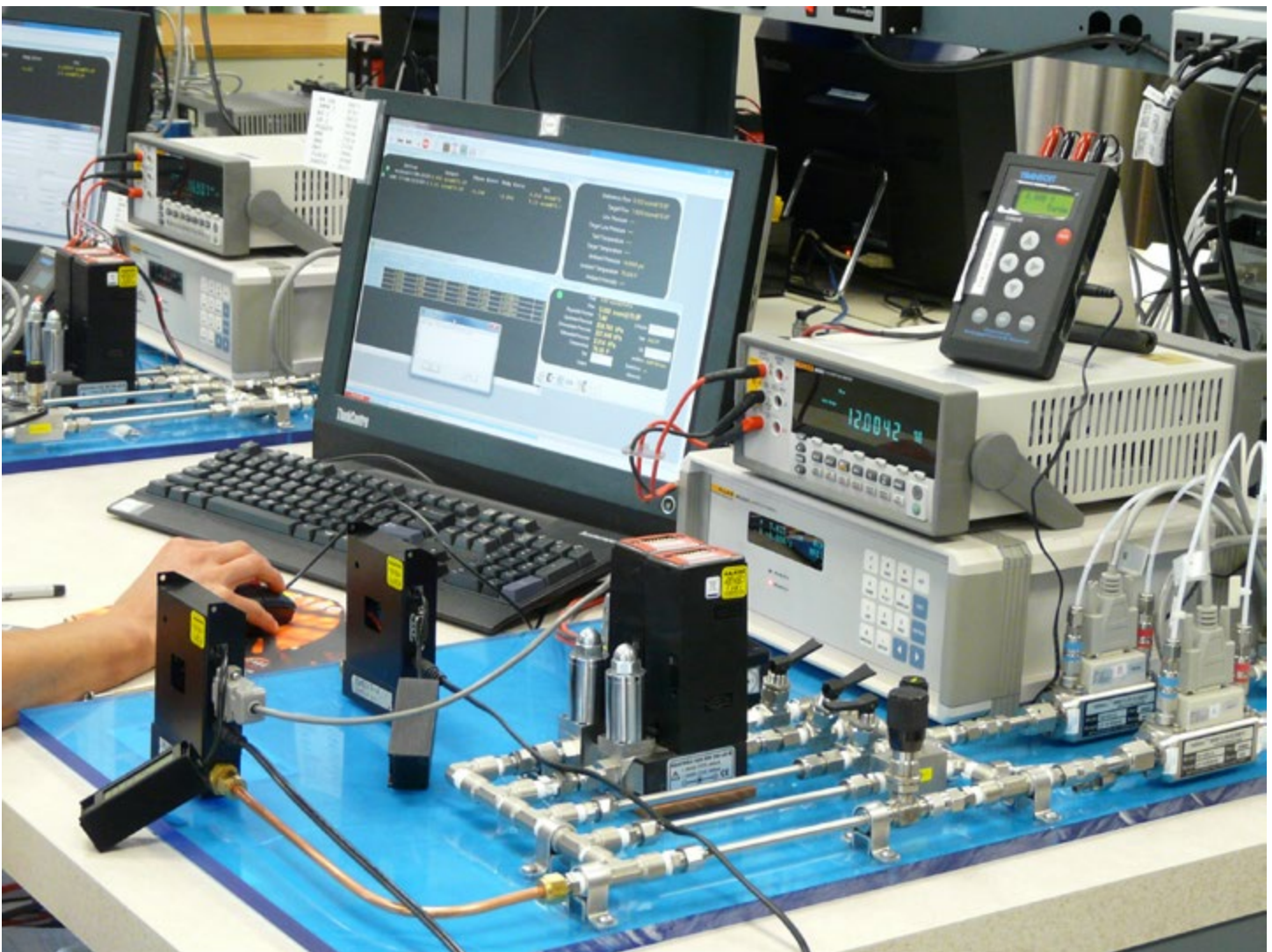

Link for an explanation how to use Molbox/Molblocs method of calibrations of Flow Meters and Controllers.

<http://www.youtube.com/watch?v=FVDqrW5y70A>

PRESSURE LIMITS OF CALIBRATIONS

Up to 500 PSIG for routine gases (Air, N₂, He and Ar) with a maximum flow of 250 L/min. Up to 80 PSIG for Air, with a maximum flow of 1000 L/min.

- ✓ Calibrations are performed at standard (STP) conditions (70 °F/21.1 °C and 14.7 psia/1 atm abs).
- ✓ Gas calibrations for up to 1000 L/min and water calibrations up to 4 L/min available.
- ✓ Calibrated to NIST traceable standards.



Bell prover used by technician in calibrating high flow capacity Flow Meter.



Terminal shown for low-flow Flow Controller calibration supported by Aalborg SDPROC software.

Piston Gauge, model 7601 with gas operated, gas lubricated piston-cylinder module. It supports definition of pressure against a vacuum reference.



OPERATING MODES: Gauge, Absolute and Differential.

OVERALL SPECIFICATION FOR PRESSURE MEASUREMENT:

Sensitivity: 0.02Pa +0.5 ppm

Reproducibility: +/-4 ppm

Measurement Uncertainty (k=2): +/- (0.5Pa + 20 ppm)

Suitable for Molbox 1+ A350/A700.



Our gas calibration laboratory has NIST traceable approved in-house equipment to certify our calibration devices. Molbox/Molblox based calibration for GFC Flow Controller.

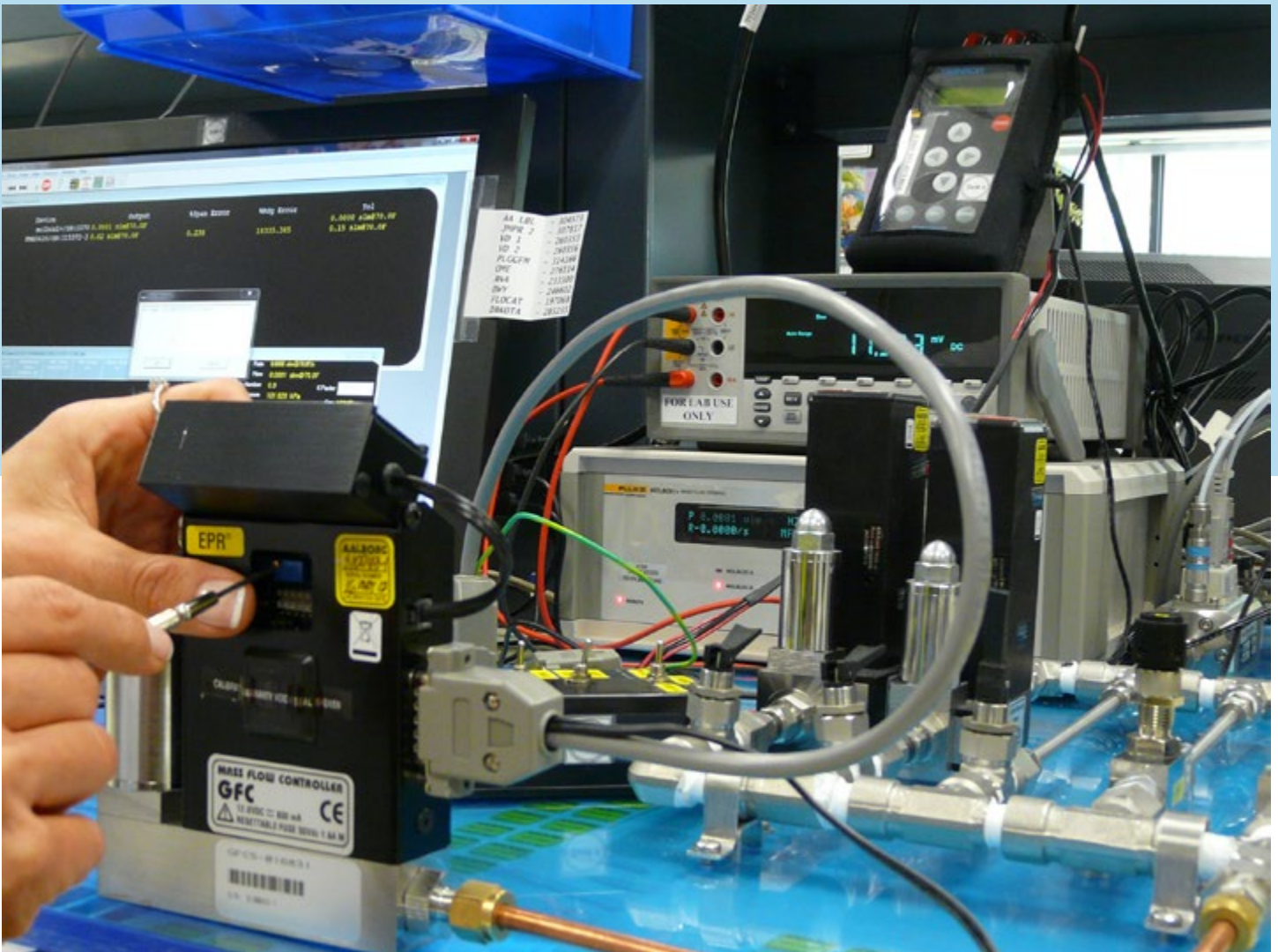

Our technicians are trained and certified and our Laboratory is equipped to calibrate Molboxes. In addition, our laboratory can calibrate NIST traceable approved “In-House” equipment to certify our primary calibration devices.

We also calibrate and certify customers’ Molboxes.

For fast cost effective service please contact our customer service department.

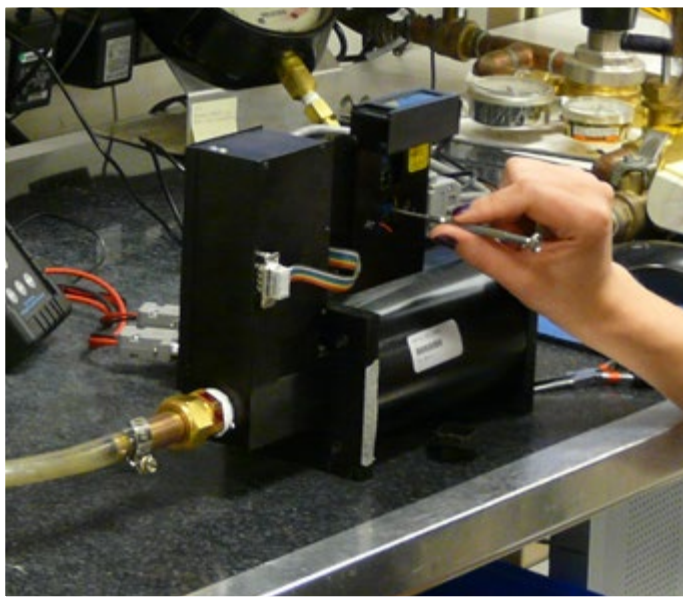

Gas flow calibration laboratory is capable of performing calibrations from 1 mL/min to 1000 L/min at 21.1 °C /101.325 kPa (70 °F, 14.69 PSI abs).

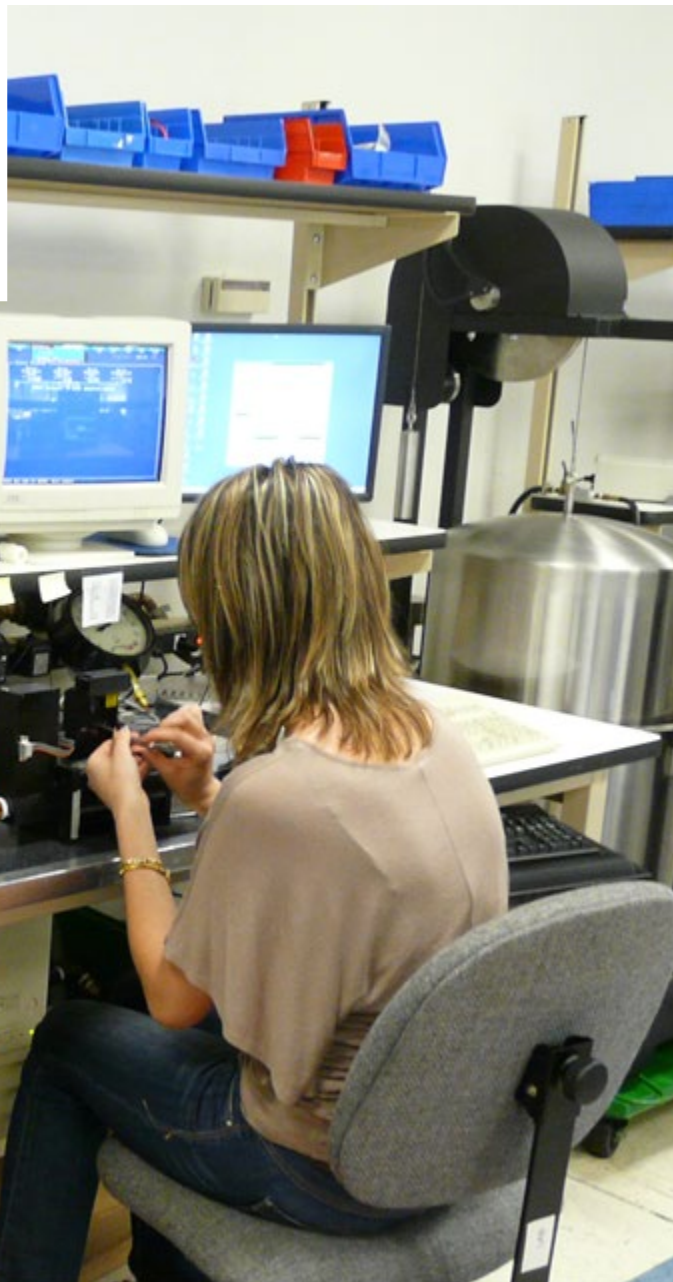

According to “state of the art” calibrating practices, calibrations are performed based on 4 to 1 uncertainty ratio.



Specialized software applied to calibration of Flow Meter.

EUROPEAN SERVICE FACILITY

Authorized Repair and Service Facility
for Aalborg Thermal Mass Flow Systems

AALBORG - ANALYT-MTC
MESSTECHNIK GMBH
Klosterrunsstraße 18 P.O. Box 1321
Müllheim D-79379 Germany

Telefon: +49 (0)7631 5545
Fax: +49 (0)7631 14740
Website: www.analyt-mtc.de
e-mail: info@analyt-mtc.de

175, avenue d'Alsace
68000 COLMAR
Tel: 03 89 41 47 78
Fax: 03 89 41 59 88
e-mail: ANALYT_MTC@T-online.de

ASIAN SERVICE FACILITY

Authorized Repair and Service Facility
for Aalborg Thermal Mass Flow Systems

**AALBORG -Beijing Comity
MEASURE & CONTROL CO.**

Floor 1 Tower B Jindayuan Office Building
Xisanqi, Hai Dian District, Beijing, China

Phone: 86-10-6295-0464, 86-10-6295-0465
Fax: 86-10-6295-0466
Website: <http://www.comity-tec.com>



**Typical Bell Prover
used for NIST traceable calibrations**





American Association for Laboratory Accreditation



Has Attended the

ISO/IEC 17025 and Accreditation Course

- ISO 17025
- Documentation
- Internal Auditing

Sponsored by the

American Association for Laboratory Accreditation

Scottsdale, AZ
1.5 CEUS Awarded
February 29-March 2, 2012

Dawn Metler
Consultant



Accredited Laboratory

A2LA has accredited

**AALFA - KAL METROLOGY LABORATORY,
DIVISION OF AALBORG INSTRUMENTS & CONTROLS, INC.**
Orangeburg, NY

for technical competence in the field of

Calibration

This laboratory is accredited in accordance with the recognized International Standard ISO/IEC 17025:2005 General requirements for the competence of testing and calibration laboratories. This laboratory also meets the requirements of ANSI/NCSL Z540-1-1994 and R205 - Specific Requirements: Calibration Laboratory Accreditation Program. This accreditation demonstrates technical competence for a defined scope and the operation of a laboratory quality management system (refer to joint ISO-ILAC-IAF Communiqué dated April 2017).



Presented this 26th day of April 2018.

President and CEO
For the Accreditation Council
Certificate Number 3989.01
Valid to April 30, 2020

For the calibrations to which this accreditation applies, please refer to the laboratory's Calibration Scope of Accreditation.



SCOPE OF ACCREDITATION TO ISO/IEC 17025:2005
& ANSI/NCSL Z540-1-1994

AALFA - KAL METROLOGY LABORATORY,
 DIVISION of AALBORG INSTRUMENTS & CONTROLS, INC.
 20 Corporate Dr.
 Orangeburg, NY 10962
 Mr. Stefan Radecki Phone: 845 770 3000

CALIBRATION

Valid To: April 30, 2020

Certificate Number: 3989.01

In recognition of the successful completion of the A2LA evaluation process, accreditation is granted to this laboratory to perform the following calibrations¹:

I. Fluid Quantities

Parameter	Range	CMC ^{2,3} (±)	Comments
Flow – Gas	Up to 20 SCCM	0.18 %	DHI Molbox-1 (Air, He, Arg, CO ₂ , O ₂ , N ₂)
	(8 to 100) SCCM	0.18 %	
	(16 to 200) SCCM	0.18 %	
	(32 to 400) SCCM	0.18 %	
	(80 to 1000) SCCM	0.18 %	
	(160 to 2000) SCCM	0.18 %	
	(800 to 10 000) SCCM	0.18 %	
	(1600 to 20 000) SCCM	0.19 %	
(4000 to 50 000) SCCM	0.27 %		

¹ This laboratory offers commercial calibration services.

² Calibration and Measurement Capability Uncertainty (CMC) is the smallest uncertainty of measurement that a laboratory can achieve within its scope of accreditation when performing more or less routine calibrations of nearly ideal measurement standards or nearly ideal measuring equipment. CMCs represent expanded uncertainties expressed at approximately the 95 % level of confidence, usually using a coverage factor of $k = 2$. The actual measurement uncertainty of a specific calibration performed by the laboratory may be greater than the CMC due to the behavior of the customer's device and to influences from the circumstances of the specific calibration.

³ In the statement of CMC, percentages represent the percent of reading unless otherwise noted.

(A2LA Cert. No. 3989.01) 04/26/2018

Page 1 of 1

5202 Presidents Court, Suite 220 | Frederick, MD 21703-8515 | Phone: 301 644 3248 | Fax: 240 454 9449 | www.A2LA.org



INTERCHANGEABLE

Designed for low flow rates, the **Model P** flow meter is a precision instrument embodying the inherent simplicity, versatility and economy of the classical rotameter. It is particularly suitable for metering carrier gases in chromatography, indicating and controlling gases in manufacturing processes, liquid and gas measurement in laboratories, pilot plants, flow and level indicating, etc.

Shipped completely assembled, flow meters include standard mounting fittings in a choice of materials, side plates, thick protective magnifying front shield and back plate, optional built-in control valve, and flow tubes selected from the Flow Capacities tables. Panel mounting style is convertible to bench mounting through the use of the optional acrylic tripod. The tripod has a built-in spirit leveler and leveling screws.

For multiple tube meters see pages 17 and 18.

design features

- ✓ Rib-guided or fluted metering tubes facilitate stable, accurate readings.
- ✓ Magnifier lens in front shield to enhance reading resolution.
- ✓ Interchangeability of flow tubes and floats.
- ✓ Ease of installation and exchange of flow tubes.
- ✓ "Non-rotating" adapter feature - glass flow tubes are prevented from turning during the tightening phase of the assembly procedure.
- ✓ OPTIGRAD™ scales minimize parallax and eye fatigue.
- ✓ Chemical compatibility.
- ✓ Simple means of panel mounting.

150 mm Meter with CV™ Valve



65 mm Meter with MFV™ Valve

BUILT-IN VALVES

Meters are available with built-in needle valves (CV™), high precision metering valves (MFV™) with “non-rising stems”, or with no valves. The higher cost of MFV™ valves is justified whenever high sensitivity control and resolution are desirable particularly in conjunction with metering tubes of very low flow rates.

Generally, for gas metering it is recommended that valves are positioned at inlets (bottom) for liquids valves may be positioned either at inlets or outlets (top). For vacuum services, valves must be mounted at outlets. If unspecified at the time of ordering, meters will be shipped with valves mounted at the inlets.

Panel mounting is convertible to bench mounting through the use of an optional acrylic tripod base with spirit leveler (catalog No. TP1).

Select flow tube consistent with requirements from flow capacity tables 6 to 22 (page 61 to 64).

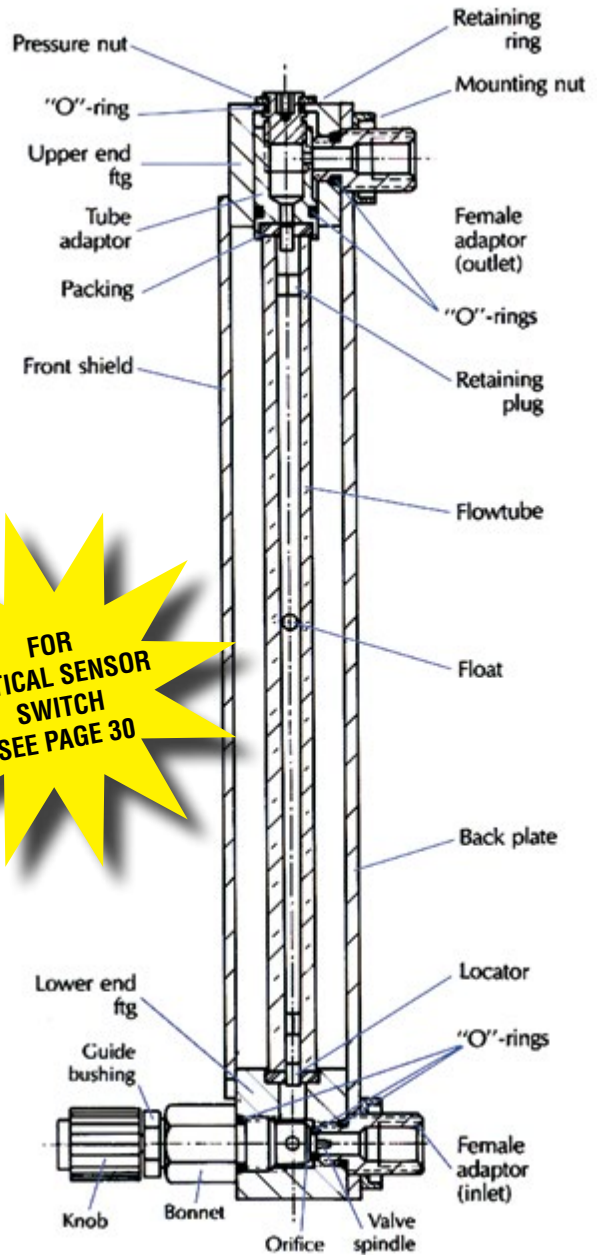

FOR OPTICAL SENSOR SWITCH SEE PAGE 30

SPECIFICATIONS	
STANDARD ACCURACY	±2% FS mm scales except 042 and 032 flow tubes. ±5% FS direct reading scales 042 and 032 flow tubes.
CALIBRATED ACCURACY	±1% FS optional.
REPEATABILITY	±0.25%.
USEFUL FLOW RANGE	10:1 minimum with one float and better than 20:1 with combination of two floats installed in meters.
MAXIMUM OPERATING PRESSURE	200 psig/13.8 bars.
MAXIMUM OPERATING TEMPERATURE	250 °F/ 121 °C.

**MATERIALS OF CONSTRUCTION	
FLOW TUBES	Heavy walled borosilicate glass.
FLOATS	Glass, Sapphire, 316 Stainless Steel, Carboloy® and Tantalum.
CHOICE OF MOUNTING FITTINGS IN CONTACT WITH FLUIDS	a) Aluminum, black anodized. b) Brass, chrome plated. c) 316 stainless steel.
SIDE PANELS	Aluminum, black anodized.
FRONT SHIELD	Lexan® with longitudinal magnifier lens for enhanced reading resolution.
BACK PLATE	1/8" thick white acrylics.
O-RINGS AND PACKING	Buna® o-rings in aluminum/ brass model. FKM o-rings in stainless steel meters. OPTIONAL FKM PTFE FFKM and EPR.
CONNECTIONS	1/8" NPT female inlet and outlet connections. OPTIONAL 1/4" FNPT, hose and compression fittings are available.

Assorted flow tubes may be used in conjunction with a single mounting frame, an apparent benefit in many laboratory applications.

**The selection of materials of construction, is the responsibility of the customer. The company accepts no liability.

Ordering information see page 21.
Dimensional information see page 20.



MULTIPLE TUBE FLOW METERS

The **Model Px** multiple tube flow meter line offers, the convenience and simplicity of 2, 3, 4, 5 and 6 tube meters, retaining most of the unique design features associated with single tube units. Multiple tube meters are available with 65mm or 150mm flow tubes same as used in single unit flow meters.

Px meters are convenient for applications where several streams of gases or liquids are to be metered in individual channels, or manifolded.

Shipped completely assembled, flow meters include standard mounting fittings in a choice of materials, side plates, thick protective front shield and back plate, optional built-in control valve, and flow tubes selected from the Flow Capacities tables.

Panel mounting style is convertible to bench mounting through the use of the optional acrylic tripod. The tripod has a built-in spirit leveler and leveling screws.

design features

- ✓ Rib-guided or fluted metering tubes facilitate stable, accurate readings.
- ✓ Interchangeability of flow tubes and floats.
- ✓ Manifolding at inlet or outlet.
- ✓ Ease of installation and exchange of flow tubes.
- ✓ "Non-rotating" adapter feature - glass flow tubes are prevented from turning during the tightening phase of the assembly procedure.
- ✓ OPTIGRAD™ scales minimize parallax and eye fatigue.
- ✓ Chemical compatibility.
- ✓ Simple means of panel mounting.

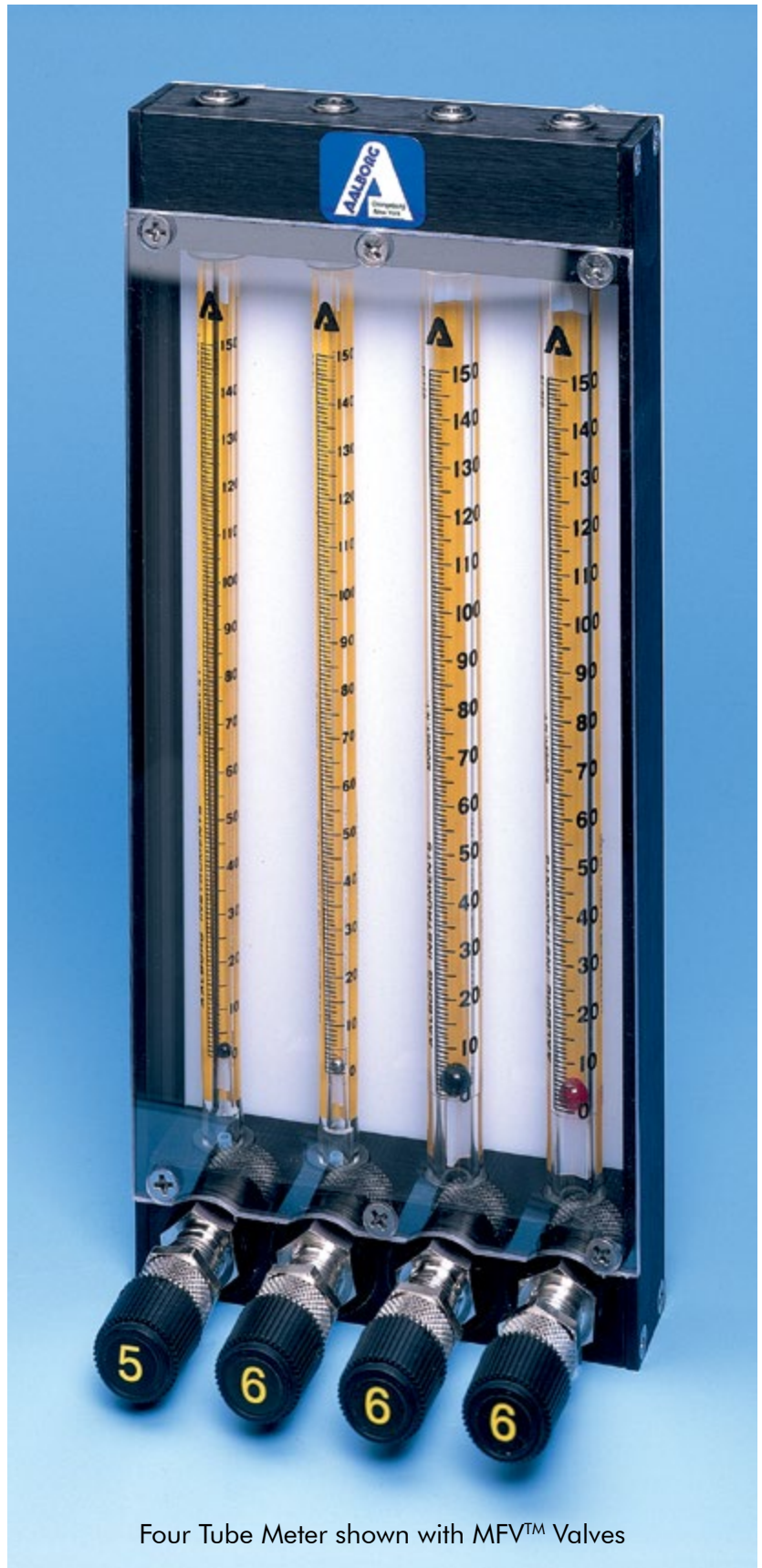

Four Tube Meter shown with MFV™ Valves

BUILT-IN VALVES

Meters may be supplied with built-in needle valves (CV™), high precision metering valves (MFV™) with “non-rising stems”, or with no valves. Generally for gas metering, it is recommended that valves are positioned at inlets (bottom) for liquids valves may be positioned either at outlets (top) or inlets. For vacuum service, valves must be mounted at outlets. If unspecified at the time of ordering, meters will be shipped with valves mounted at inlets.

MOUNTING DIMENSIONS

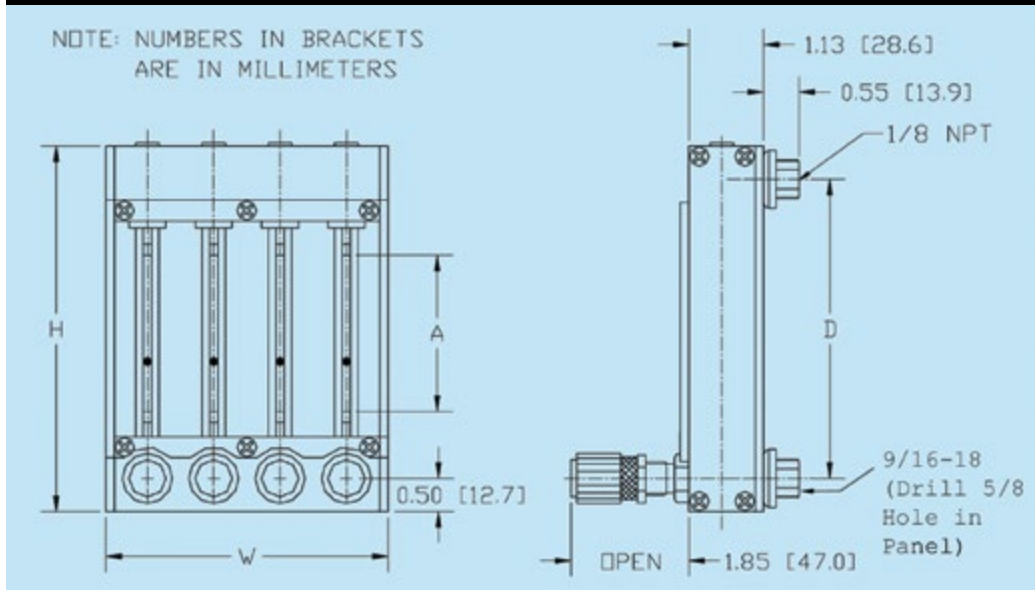

NOTE: Aalborg® reserves the right to change designs and dimensions at its sole discretion at any time without notice. For certified dimensions please contact Aalborg®.

SPECIFICATIONS

STANDARD ACCURACY

±2% FS mm scales except 042 and 032 flow tubes.
 ±5% FS direct reading scales 042 and 032 flow.
 Conforming to ISA RP. 16-1.2.3
Specification 2-S-10. Manifoldd models excepted.

CALIBRATED ACCURACY

±1% FS optional.

REPEATABILITY ±0.25%.

USEFUL FLOW RANGE

10:1 minimum with one float. Better than 20:1 with combinations of two floats installed in meters.

MAXIMUM OPERATING PRESSURE

200 psig/13.8 bars.

MAXIMUM OPERATING TEMPERATURE

250 °F/ 121 °C.

**MATERIALS OF CONSTRUCTION

FLOW TUBES Heavy walled borosilicate glass.

CHOICE OF MOUNTING FITTINGS IN CONTACT WITH FLUIDS

- a) Aluminum, black anodized.
- b) 316 Stainless Steel.

SIDE PANELS Aluminum, black anodized.

FRONT SHIELD AND BACK PLATE

1/8" thick clear polycarbonate and white acrylics.

O-RINGS AND PACKING

Buna® O-rings in aluminum model.
 FKM O-rings in stainless steel meters.
OPTIONAL FKM, PTFE/FFKM, EPR.

CONNECTIONS 1/8" NPT female inlet and outlet connections.

OPTIONAL: 1/4" FNPT, hose & compression fittings are available.

Ordering information see page 21.

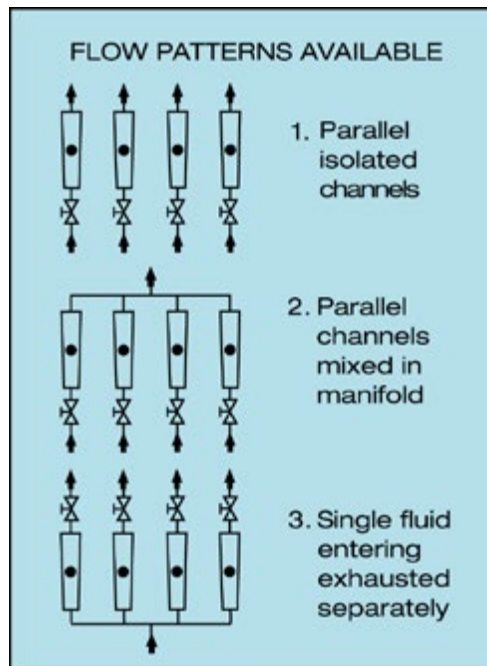

The built-in-valves are always installed in the end block opposite to the manifolded one.

Thus, if a meter is manifolded at the outlet, valves are installed at the inlets; if a meter is manifolded at the inlet, valves are installed at the outlets.

DIMENSIONS FOR P STYLE METERS

SCALE LENGTH (A)	ALL P METERS		WIDTH (W)					
	HEIGHT (H)	CENTER TO CENTER (D)	1 TUBE	2 TUBE	3 TUBE	4 TUBE	5 TUBE	6 TUBE
65mm	5.500	4.500	1.250	2.250	3.250	4.250	5.250	6.250
150mm	9.813	8.813	1.250	2.250	3.250	4.250	5.250	6.250

**The selection of materials of construction, is the responsibility of the customer. The company accepts no liability.



ORDERING INFORMATION MODEL P METERS

Configure and Order Online: [Model P Single Flow Tube meters](#)
[Model Px Multi Flow Tube Meters](#)

P	P STYLE METERS	
CODE	NUMBER OF CHANNELS	
1	SINGLE CHANNEL (ONE TUBE)	
2	TWO CHANNEL METER (TWO TUBES)	
3	THREE CHANNEL METER (THREE TUBES)	
4	FOUR CHANNEL METER (FOUR TUBES)	
5	FIVE CHANNEL METER (FIVE TUBES)	
6	SIX CHANNEL METER (SIX TUBES)	
CODE	SIZE	
6	65 mm	
1	150 mm	
CODE	MATERIAL	
A	ALUMINUM	
B	BRASS	
S	STAINLESS STEEL	
CODE	VALVE POSITION	
1	MFV (HIGH PRECISION) INLET	
3	NO VALVE	
4	CV (STANDARD CARTRIDGE) INLET	
5	MFV (HIGH PRECISION) OUTLET	
6	CV (STANDARD CARTRIDGE) OUTLET	
CODE	SEALS	
V	FKM STANDARD ON STAINLESS METERS	
B	BUNA® STANDARD ON BRASS AND ALUMINUM	
E	EPR	
T	PTFE / FFKM	
CODE	FITTINGS	
A	1/8" FNPT (STANDARD)	
B	1/4" FNPT	
C	1/8" HOSE NIPPLE	
D	1/4" HOSE NIPPLE	
E	1/8" COMPRESSION	
F	1/4" COMPRESSION	
H	VCR FITTINGS	
CODE	MANIFOLD	
0	NONE (STANDARD FOR SINGLE CHANNEL)	
1	BOTTOM	
2	TOP	

P 1 1 A 4 — B B 0 — *TUBE

EXAMPLE: P11A4-BB0

P Style Meter, Single Channel, 150 mm, Aluminum, Standard Valve at inlet, Buna Seals, 1/4" fitting, No Manifold.

Optional Accessories

- TP1-Tripod for single channel meter.
- TP2-Tripod for 2, 4 and 6 isolated channels or manifolding at top.
- TP3-Tripod for 3 and 5 isolated channels or manifolding at bottom.
- TP5-Tripod for 3 single tube meters.

*Tube selection:

- Millimeter tubes: Tables 6 thru 9
- Direct Reading tubes: Tables 11 thru 22.

GENERAL DESCRIPTION

Model T flow meters incorporate the principles of traditional variable area flow technology.

These rugged PTFE-Glass flow meters offer solutions to low to medium flow range measurements of highly corrosive or ultra-pure liquids and gases.

Wetted inert components are surrounded by structurally rigid anodized aluminum. The resultant design represents a unique combination of a rugged mechanically rigid frame and chemically inert wetted parts.

For additional protection of personnel each meter is supplied with a thick protective magnifying safety shield.

*Glass and Sapphire floats are recommended.

design features

- ✓ Constructed of inert materials: Borosilicate Glass, PTFE and PEEK.
- ✓ Chemically inert wetted parts within mechanically rigid frame.
- ✓ Rib-guided or fluted metering tubes facilitate stable, accurate readings.
- ✓ Magnifier lens in front shield to enhance reading resolution.
- ✓ OPTIGRAD™ scales minimize parallax and eye fatigue.
- ✓ Simple means of panel mounting.
- ✓ Interchangeability of flow tubes and floats.
- ✓ Conveniently overlapping flow ranges available in both standard millimeter and "direct reading" scales.



PTFE 150mm
with MVT™ Valve

PTFE 65mm
with CVT™ Valve

T

PTFE-SINGLE GLASS FLOW METERS

LEAK INTEGRITY

Flow meters are individually tested on a Mass Spectrometer Leak Detector and certified to a leak integrity rating of 1×10^{-7} sccs Helium or better.

BUILT-IN VALVES

Meters are available with built-in needle valves (CVT™), high precision metering valves (MVT™) with “non-rising stems”, or with no valves. The higher cost of MVT™ valves is justified whenever high sensitivity control and resolution are desirable particularly in conjunction with metering tubes of very low flow rates.

When meters with valves are ordered the valve cartridges are installed at the inlet. For vacuum service it is recommended that meters are ordered with valves at the outlet.

Assorted flow tubes may be used in conjunction with a single mounting frame, an apparent benefit in many laboratory applications.

SPECIFICATIONS

STANDARD ACCURACY	±2% FS mm scales except 042 and 032 flow tubes. ±5% FS direct reading scales 042 and 032 flow tubes.
REPEATABILITY	± 0.25%.
USEFUL FLOW RANGES	10:1 minimum with one float.
MAXIMUM OPERATING PRESSURE	100 psig/6.7 bars.
MAXIMUM OPERATING TEMPERATURE	150 °F/ 65 °C.
LEAK INTEGRITY	Individually pressure and leak tested and certified to a rating of 1×10^{-7} sccs Helium.

**MATERIALS OF CONSTRUCTION

FLOW TUBES	Heavy walled borosilicate glass. (Sapphire or glass floats recommended).
FITTINGS IN CONTACT WITH FLUIDS	Virgin PTFE and PEEK.
SIDE PLATES	Aluminum, black anodized.
FRONT SHIELD AND BACK PLATE	1/8" thick clear polycarbonate and white acrylics.
O-RINGS	PTFE.
CONNECTIONS	1/8" NPT female inlet and outlet connections.
OPTIONAL	glass hose nipples or compression fittings.

**The selection of materials of construction, is the responsibility of the customer. The company accepts no liability.

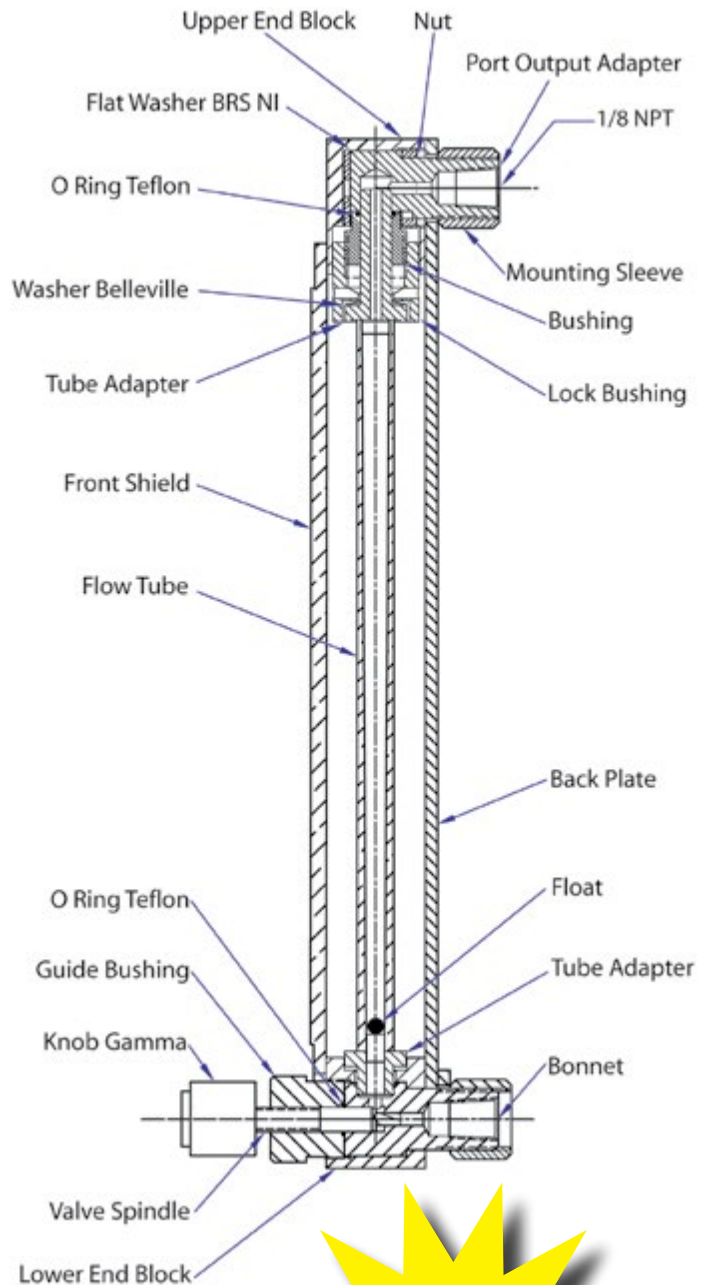

**FOR
OPTICAL SENSOR
SWITCH
SEE PAGE 30**

Panel mounting is convertible to bench mounting through the use of an optional acrylic tripod base with spirit leveler (catalog No. TP1)

**Ordering information see page 26.
Dimensional information see page 25.**

Four Tube PTFE meter shown with CVT™ valves



Model Tx Multiple Tube PTFE-Glass Flow meters combine the convenience of multiple tube meters with the unique design features of single tube PTFE-Glass flow meters. These meters are available with the same interchangeable 65mm or 150mm glass flow tubes used in single tube designs and they are available with or without built-in PTFE needle valves.

Wetted inert components are surrounded by structurally rigid anodized aluminum. The resultant design represents a unique combination of a rugged mechanically rigid frame and chemically inert wetted parts.

They are ideal for applications where several streams of corrosive gases or liquids are to be metered in individual channels or as a controlled mixer in manifolded models.

design features

- ✓ Constructed of inert materials: Borosilicate Glass, PTFE and PEEK.
- ✓ Chemical inert wetted parts within mechanically rigid frame.
- ✓ Rib-guided or fluted metering tubes facilitate: stable, accurate readings.
- ✓ OPTIGRAD™ scales minimize parallax and eye fatigue.
- ✓ Simple means of panel mounting.
- ✓ Interchangeability of flow tubes and floats.
- ✓ Conveniently overlapping flow ranges available in both standard millimeter and direct reading scales.



PTFE-SINGLE GLASS FLOW METERS

BUILT-IN VALVES

Meters are available with built-in needle valves (CVT™), high precision metering valves (MVT™) with non-rising stems, or with no valves. The higher cost of MVT™ valves is justified whenever high sensitivity control and resolution are desirable particularly in conjunction with metering tubes of very low flow rates.

For vacuum service it is recommended that meters are ordered with valves at the outlet.

DIMENSIONS

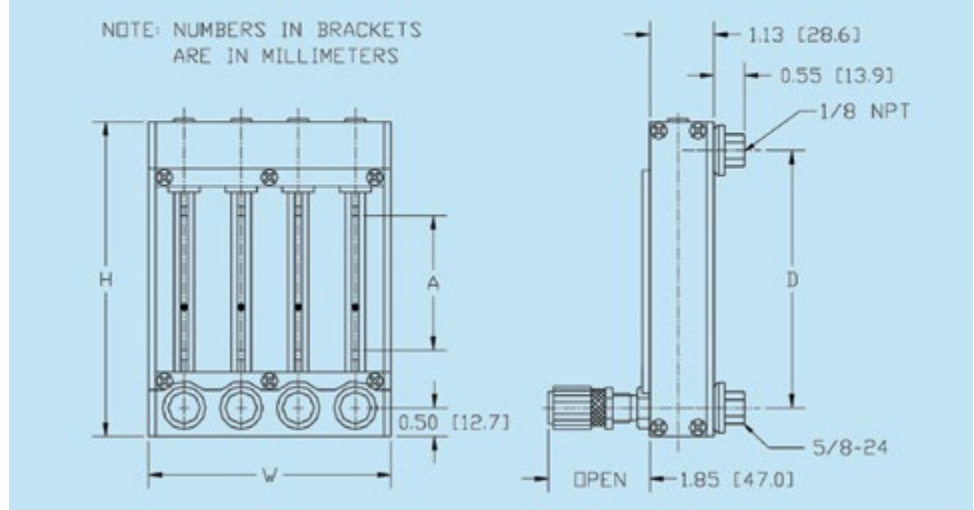

Note: To obtain millimeters multiply inch dimensions by 2.54.

NOTE: Aalborg® reserves the right to change designs and dimensions at its sole discretion at any time without notice. For certified dimensions please contact Aalborg®.

LEAK INTEGRITY

Flow meters are individually tested on a Mass Spectrometer Leak Detector and certified to a leak integrity rating of 1×10^{-7} sccs Helium or better.

SPECIFICATIONS

STANDARD ACCURACY	±2% FS mm scales except 042 and 032 flow tubes. ±5% FS direct reading scales and 042 and 032 flow tubes.
REPEATABILITY	± 0.25%.
USEFUL FLOW RANGES	10:1 minimum with one float.
MAXIMUM OPERATING PRESSURE	100 psig/6.7 bars.
MAXIMUM OPERATING TEMPERATURE	150 °F/ 65 °C.
LEAK INTEGRITY	Individually pressure and leak tested and certified to a rating of 1×10^{-7} sccs Helium.

**MATERIALS OF CONSTRUCTION

FLOW TUBES	Heavy walled borosilicate glass. (Sapphire or glass floats recommended).
FITTINGS IN CONTACT WITH FLUIDS	Virgin PTFE and PEEK.
SIDE PLATES	Aluminum, black anodized.
FRONT SHIELD AND BACK PLATE	1/8" thick clear polycarbonate and white acrylics.
O-RINGS	PTFE.
CONNECTIONS	1/8" NPT female inlet and outlet connections.
OPTIONAL	glass hose nipples or compression fittings.

**The selection of materials of construction, is the responsibility of the customer. The company accepts no liability.

FLOW PATTERNS AVAILABLE

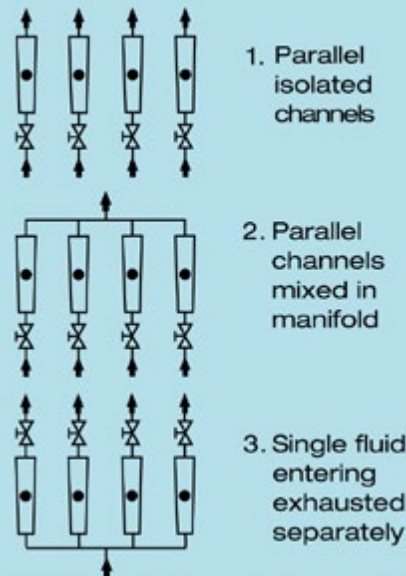

When meters with valves are ordered the valve cartridges are installed at the inlet.

DIMENSIONS FOR T STYLE METERS

SCALE LENGTH (A)	ALL METERS		WIDTH (W)			
	HEIGHT (H)	CENTER TO CENTER (D)	TUBE 1	TUBE 2	TUBE 3	TUBE 4
65mm	6.156	5.156	1.250	2.250	3.250	4.250
150mm	10.46	9.469	1.250	2.250	3.250	4.250

ORDERING INFORMATION MODEL T METERS



Configure and Order Online: [Model T Single Flow Tube PTFE Meters](#)
[Model Tx Multi Flow Tube PTFE Meters](#)

T	T STYLE METERS												
	<table border="1"> <thead> <tr> <th>CODE</th> <th>NUMBER OF CHANNELS</th> </tr> </thead> <tbody> <tr> <td>1</td> <td>SINGLE CHANNEL (ONE TUBE)</td> </tr> <tr> <td>2</td> <td>TWO CHANNEL METER (TWO TUBES)</td> </tr> <tr> <td>3</td> <td>THREE CHANNEL METER (THREE TUBES)</td> </tr> <tr> <td>4</td> <td>FOUR CHANNEL METER (FOUR TUBES)</td> </tr> </tbody> </table>	CODE	NUMBER OF CHANNELS	1	SINGLE CHANNEL (ONE TUBE)	2	TWO CHANNEL METER (TWO TUBES)	3	THREE CHANNEL METER (THREE TUBES)	4	FOUR CHANNEL METER (FOUR TUBES)		
CODE	NUMBER OF CHANNELS												
1	SINGLE CHANNEL (ONE TUBE)												
2	TWO CHANNEL METER (TWO TUBES)												
3	THREE CHANNEL METER (THREE TUBES)												
4	FOUR CHANNEL METER (FOUR TUBES)												
	<table border="1"> <thead> <tr> <th>CODE</th> <th>SIZE</th> </tr> </thead> <tbody> <tr> <td>6</td> <td>65 mm</td> </tr> <tr> <td>1</td> <td>150 mm</td> </tr> </tbody> </table>	CODE	SIZE	6	65 mm	1	150 mm						
CODE	SIZE												
6	65 mm												
1	150 mm												
	<table border="1"> <thead> <tr> <th>CODE</th> <th>MATERIAL</th> </tr> </thead> <tbody> <tr> <td>T</td> <td>PTFE</td> </tr> </tbody> </table>	CODE	MATERIAL	T	PTFE								
CODE	MATERIAL												
T	PTFE												
	<table border="1"> <thead> <tr> <th>CODE</th> <th>VALVE POSITION</th> </tr> </thead> <tbody> <tr> <td>1</td> <td>MFV (HIGH PRECISION) INLET</td> </tr> <tr> <td>3</td> <td>NO VALVE</td> </tr> <tr> <td>4</td> <td>CV (STANDARD CARTRIDGE) INLET</td> </tr> <tr> <td>5</td> <td>MFV (HIGH PRECISION) OUTLET</td> </tr> <tr> <td>6</td> <td>CV (STANDARD CARTRIDGE) OUTLET</td> </tr> </tbody> </table>	CODE	VALVE POSITION	1	MFV (HIGH PRECISION) INLET	3	NO VALVE	4	CV (STANDARD CARTRIDGE) INLET	5	MFV (HIGH PRECISION) OUTLET	6	CV (STANDARD CARTRIDGE) OUTLET
CODE	VALVE POSITION												
1	MFV (HIGH PRECISION) INLET												
3	NO VALVE												
4	CV (STANDARD CARTRIDGE) INLET												
5	MFV (HIGH PRECISION) OUTLET												
6	CV (STANDARD CARTRIDGE) OUTLET												
	<table border="1"> <thead> <tr> <th>CODE</th> <th>SEALS</th> </tr> </thead> <tbody> <tr> <td>T</td> <td>PTFE</td> </tr> </tbody> </table>	CODE	SEALS	T	PTFE								
CODE	SEALS												
T	PTFE												
	<table border="1"> <thead> <tr> <th>CODE</th> <th>FITTINGS</th> </tr> </thead> <tbody> <tr> <td>A</td> <td>1/8" FNPT (STANDARD)</td> </tr> <tr> <td>F</td> <td>1/4" COMPRESSION</td> </tr> <tr> <td>G</td> <td>0.390 O.D. GLASS HOSE NIPPLE</td> </tr> </tbody> </table>	CODE	FITTINGS	A	1/8" FNPT (STANDARD)	F	1/4" COMPRESSION	G	0.390 O.D. GLASS HOSE NIPPLE				
CODE	FITTINGS												
A	1/8" FNPT (STANDARD)												
F	1/4" COMPRESSION												
G	0.390 O.D. GLASS HOSE NIPPLE												
	<table border="1"> <thead> <tr> <th>CODE</th> <th>MANIFOLD</th> </tr> </thead> <tbody> <tr> <td>0</td> <td>NONE (STANDARD FOR SINGLE CHANNEL)</td> </tr> <tr> <td>1</td> <td>BOTTOM</td> </tr> <tr> <td>2</td> <td>TOP</td> </tr> </tbody> </table>	CODE	MANIFOLD	0	NONE (STANDARD FOR SINGLE CHANNEL)	1	BOTTOM	2	TOP				
CODE	MANIFOLD												
0	NONE (STANDARD FOR SINGLE CHANNEL)												
1	BOTTOM												
2	TOP												
T	1 1 T 3 — T F 0 — *TUBE												

EXAMPLE: T11T3-TF0

T-Style Meter, Single Channel, 150mm, PTFE, No Valve, PTFE Seals, 1/4" compression fittings, No Manifold.

Optional Accessories

- TP1-Tripod for single channel meter.
- TP2-Tripod for 2 and 4 isolated channels or manifolding at top.
- TP3-Tripod for 3 isolated channels or manifolding at bottom.
- TP5-Tripod for 3 single tube meters.

*Tube selection:

- Millimeter tubes: Tables 6 thru 9
- Direct Reading tubes: Tables 11 thru 22.



SINGLE TUBE FLOW METERS

S STYLE

Model S single-tube flow meters pictured on this page are similar to P meters in design, employing the same interchangeable flow tubes, valves and accessories. Likewise they may be panel or bench mounted.



The important advantage of the S meter is convenience in applications, where frequent changing of tubes in meter cases is desired.

An example is when several flow tubes are used in conjunction with a single meter case, or when because of the nature of the fluid, periodic cleaning necessitates disassembly.

Aalborg's® exclusive TUBELOK™ design facilitates simple installation and replacement of tubes in mounting cases.

As a result of the “non-rotating” adapter feature, glass flow tubes are prevented from turning during the tightening phase of the assembly procedure.

design features

- ✓ TUBELOK™ design simplifies installation and replacement of tubes.
- ✓ Rib-guided or fluted metering tubes facilitate stable, accurate readings.
- ✓ Magnifier lens in front shield to enhance reading resolution.
- ✓ OPTIGRAD™ scales minimize parallax and eye fatigue.
- ✓ Simple means of panel mounting.
- ✓ Interchangeable flow tubes and floats.

BUILT-IN VALVES

Meters are available with built-in needle valves (CV™), high precision metering valves (MFV™) with “non-rising stems”, or with no valves. The higher cost of MFV™ valves is justified whenever high sensitivity control and resolution are desirable particularly in conjunction with metering tubes of very low flow rates. Generally, for gas metering it is recommended that valves are positioned at inlets (bottom) for liquids valves may be positioned either at inlets or outlets (top). For vacuum services, valves must be mounted at outlets. If unspecified at the time of ordering, meters will be shipped with valves mounted at the inlets.

SPECIFICATIONS

STANDARD ACCURACY	±2% FS mm scales except 042 and 032 flow tubes. ±5% FS direct reading scales and 042 and 032 flow tubes.
CALIBRATED ACCURACY	±1% FS optional.
REPEATABILITY	±0.25%.
USEFUL FLOW RANGE	10:1 minimum with one float. Better than 20:1 with combination of two floats installed in meters.
MAXIMUM OPERATING TEMPERATURE	200 psig/13.8 bars.
MAXIMUM OPERATING TEMPERATURE	250 °F/ 121 °C.

**MATERIALS OF CONSTRUCTION

FLOW TUBES	Heavy walled borosilicate glass.
FLOATS	Glass, Sapphire, 316 Stainless Steel, Carboloy® and Tantalum.
CHOICE OF MOUNTING FITTINGS IN CONTACT WITH FLUIDS	a) Aluminum, black anodized. b) Brass, chrome plated. c) 316 stainless steel.
SIDE PANELS	Aluminum, black anodized.
FRONT SHIELD	Lexan® with longitudinal magnifier lens for enhanced reading resolution.
BACK PLATE	1/8" thick white acrylics.
O-RINGS AND PACKING	Buna® o-rings in aluminum model. FKM o-rings in stainless steel meters. OPTIONAL FKM, PTFE/FFKM and EPR.
CONNECTIONS	1/8" NPT female inlet and outlet connections.
OPTIONAL	1/4" FNPT, hose and compression fittings are available.

**The selection of materials of construction, is the responsibility of the customer. The company accepts no liability.

DIMENSIONS FOR S STYLE METERS

SCALE LENGTH (A)	ALL METERS	
	HEIGHT (H)	CENTER TO CENTER (D)
65mm	6.156	5.156
150mm	10.46	9.469

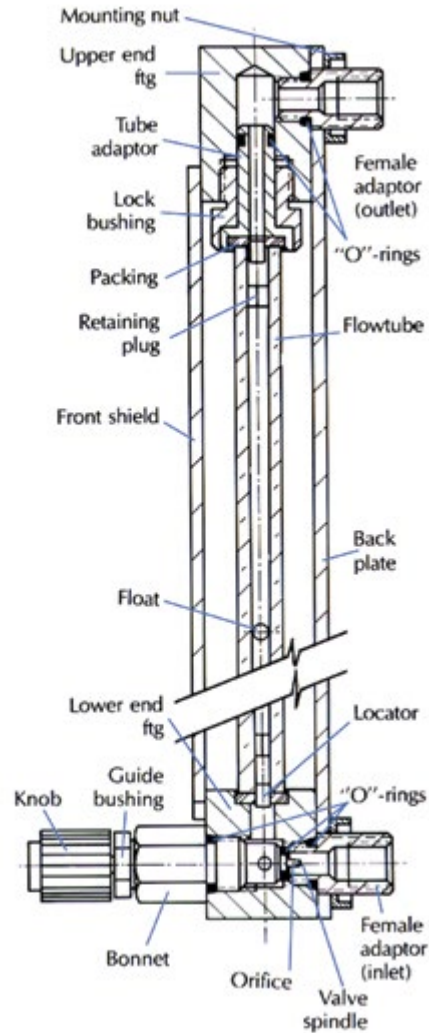

DIMENSIONS

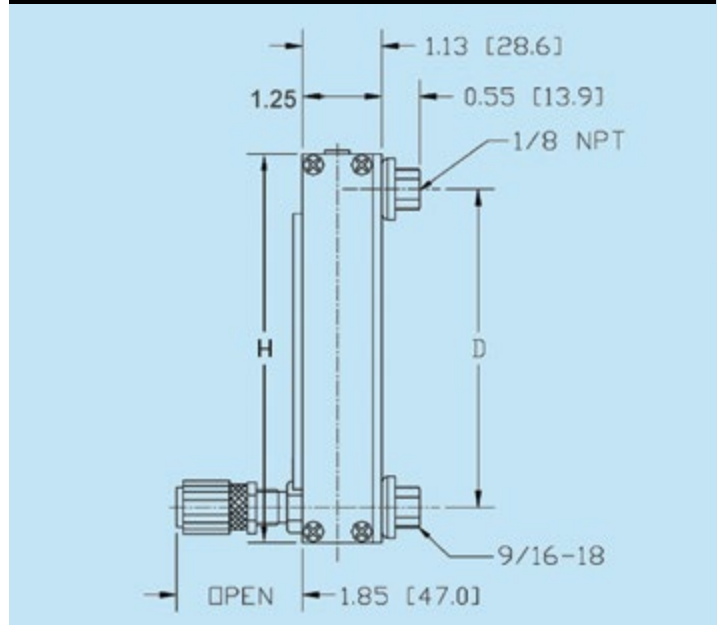

NOTE: Aalborg® reserves the right to change designs and dimensions at its sole discretion at any time without notice. For certified dimensions please contact Aalborg®.

S

ORDERING INFORMATION MODEL S METERS

Configure and Order Online: [Model S Single Tube Flow Meters](#)

CODE	
S	S STYLE METERS

CODE	NUMBER OF CHANNELS
1	SINGLE CHANNEL (ONE TUBE)

CODE	SIZE
6	65 mm
1	150 mm

CODE	MATERIAL
A	ALUMINUM
B	BRASS
S	STAINLESS STEEL

CODE	VALVE POSITION
1	MFV (HIGH PRECISION) INLET
3	NO VALVE
4	CV (STANDARD CARTRIDGE) INLET
5	MFV (HIGH PRECISION) OUTLET
6	CV (STANDARD CARTRIDGE) OUTLET

CODE	SEALS
V	FKM STD ON STAINLESS METERS
B	BUNA® STD ON BRASS AND ALUMINUM
E	EPR
T	PTFE/FFKM

CODE	FITTINGS
A	1/8" FNPT
B	1/4" FNPT
C	1/8" HOSE NIPPLE
D	1/4" HOSE NIPPLE
E	1/8" COMPRESSION
F	1/4" COMPRESSION
G	VCR

CODE	MANIFOLD
0	NONE

S 1 6 S 1 — V A 0 — *TUBE

EXAMPLE: S16S1-VA0

S-Style meter, Single Channel, 65mm, Stainless, High precision valve at inlet, FKM Seals, 1/8" FNPT fittings, No Manifold.

Optional Accessories

TP1-Tripod for single channel meter.

*Tube selection:

Millimeter tubes: Tables 6 thru 9

Direct Reading tubes: Tables 11 thru 22.

P Style Meter with Single Optical Sensor Switch

GENERAL DESCRIPTION

The Optical Sensor Switch is a non-invasive means for detection of a HI or LOW flow. This sensor is ideal for signaling an alarm, cutoff valve, or other device when the float passes the detector (alarm, valve, etc. are not included). The Optical Sensor Switch helps protect processes and equipment from damage caused by extreme flow rates.

Used in conjunction with P, S and T Style Flow Meters.

Its compact design and ease of operation make it a non-obtrusive, simple to use addition to your flow meter. Perfect for OEM applications, use whenever maximum or minimum flow levels need to be monitored automatically. It also can be used in conjunction with a control relay to power alternate equipment or monitoring devices.

PRINCIPLE OF OPERATION

A self-contained miniature photoelectric sensor (Thrubeam type) consisting of a transmitter and receiver are mounted at opposite sides of the flow tube on a solid carrier. The float inside the flow tube is detected as it passes across the beam of light. The sensor can be used to detect the float passage beyond the setpoint of the sensor and can also be set to monitor the float position at a specific level, signaling when the float is outside of the range of the sensor light beam.

PICTURE SHOWING
OPTICAL SENSOR SWITCHES
INSTALLED ON A
TYPICAL ROTAMETER

Configure and Order Online:

[Optical Sensor Switch for Rotameters \(Single\)](#)

To order a flow meter with a single Optical Sensor Switch add "O1-" to P, S, or T Model Numbers.

Example: O1-P11A4-BA0-032-41-ST-VN.



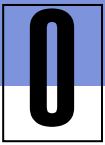

OPTICAL SENSOR SWITCH

OPTICAL SENSOR SWITCH CONNECTION	
WIRE LEAD COLOR	CONNECTION
BLACK	Positive Power Lead (+10 to 30 VDC)
YELLOW	Negative Power Lead
GREEN	NPN output #1
RED	NPN output #2 (Complementary to Output #1)

ORDERING INFORMATION FOR OPTICAL SENSOR SWITCH ACCESSORY	
PART NUMBER	DESCRIPTION
OSV1-6-P	Optical Sensor Switch for 65mm P Style Meters
OSV1-1-P	Optical Sensor Switch for 150mm P Style Meters
OSV1-6-S	Optical Sensor Switch for 65mm S Style Meters
OSV1-1-S	Optical Sensor Switch for 150mm S Style Meters
OSV1-6-T	Optical Sensor Switch for 65mm T Style Meter
OSV1-1-T	Optical Sensor Switch for 150mm T Style Meter

The sensor consists of two parts: transmitter and receiver. When power is properly connected the power supply indicator (green LED) on the transmitter is constantly on.

The receiver has two indicators:

Stable operation indicator (green LED) turns on with a stable incoming beam and with a stable blocked light. Output indicator (orange LED) turns on when the beam from emitter is blocked by the float.

TROUBLESHOOTING		
PROBLEM	CAUSE	CHECK & ACTION
All indicators are off.	The power supply is not connected.	Connect the power supply.
The output indicators turn on and off but output does not turn on or off.	Incorrect wiring.	Check the wiring for the output wires.
	The input device has failed. Sensor output has failed or an output wire is broken.	Try connecting the sensor output to a separate input device.
The output indicator is flashing.	Overcurrent has passed through an output.	Check that the rated current for the input device has not exceeded 50 mA.
		Check that the output wires are not shorted by any other wires.
	The sensor is affected by ambient light.	When there are light sources nearby (sensors, lighting), adjust the sensor installation.



PR-F

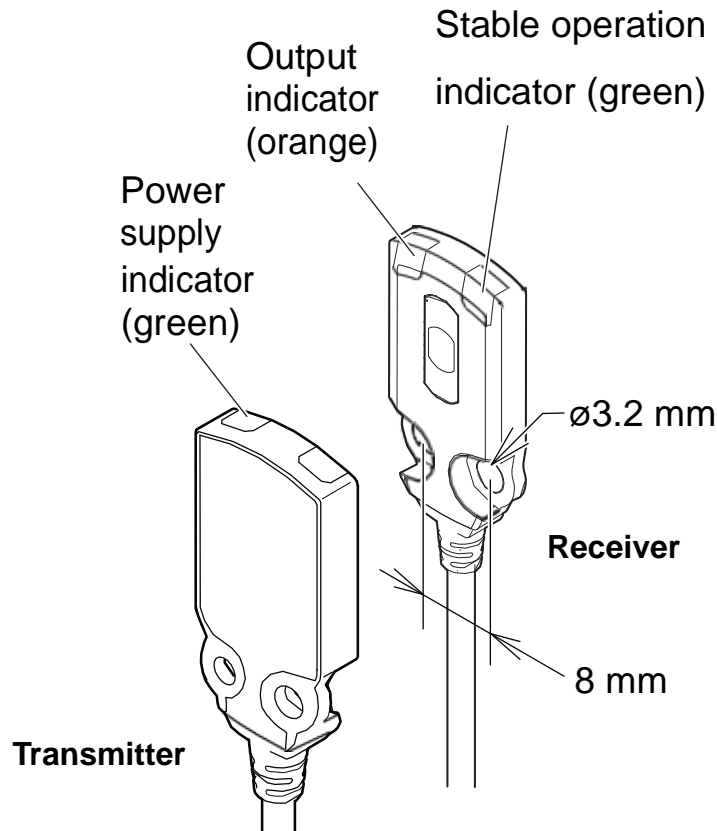

Output Wiring Diagram

• NPN

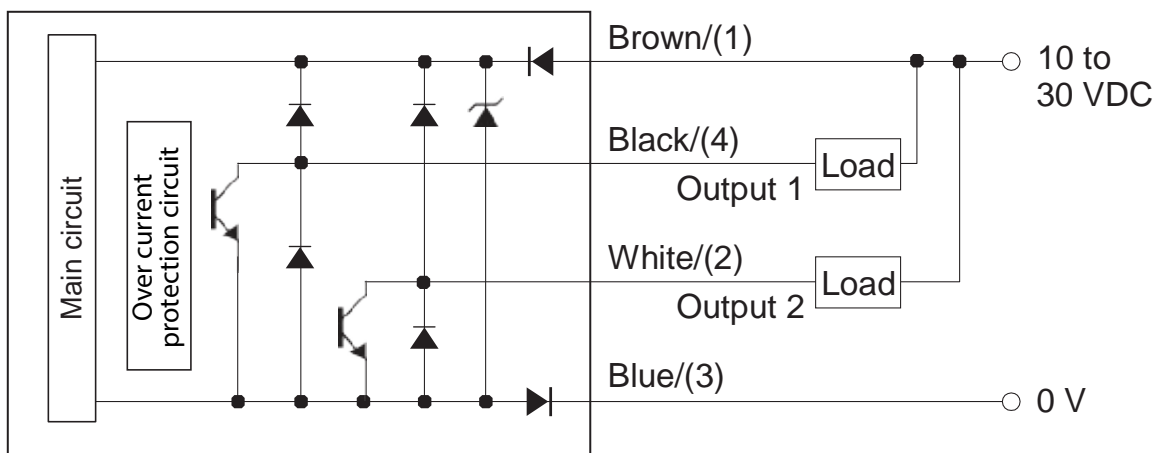

P Style Meter
with Double Optical Sensor Switches

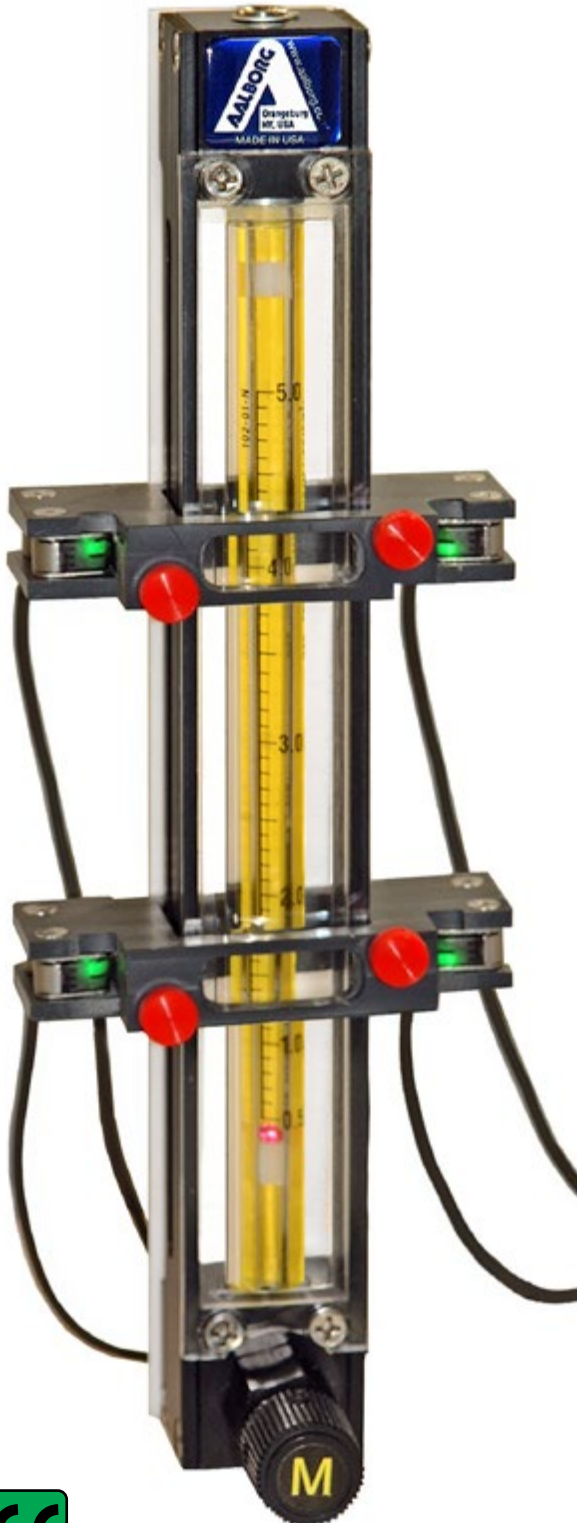

GENERAL DESCRIPTION

The Optical Sensor Switch Hi-Lo is a non-invasive means for detection of a HI or LOW flow. This set of sensors is ideal for signaling an alarm, cutoff valve, or other device when the float passes the detector (alarm, valve, etc. are not included). The Optical Sensor Switch helps protect processes and equipment from damage caused by extreme flow rates.

Its compact design and ease of operation make it a non-obtrusive, simple to use addition to your flow meter. Perfect for OEM applications, use whenever maximum or minimum flow levels need to be monitored automatically. It also can be used in conjunction with a control relay to power alternate equipment or monitoring devices.

Used in conjunction with P, S and T
Style Flow Meters.

PRINCIPLE OF OPERATION

The Optical Sensor Switch Hi-Lo consists of two self-contained mini-slim photoelectric sensors (Thrubeam type). Every sensor has a transmitter and receiver. Two sets of sensors are mounted on two solid carriers on opposite sides of the flow tube. The float inside the flow tube is detected as it passes across the beam of light. The sensors can be used to detect the float passage beyond the setpoint of the sensor and can also be set to monitor the float position at a specific level, signaling when the float is outside of the range of the sensor light beam.

Configure and Order Online:

[Optical Sensor Switch for Rotameters \(Double\)](#)

To order a flow meter with Hi-Lo Optical Sensor Switches add "O2-" to P, S, or T Model Numbers.

Example: O2-P11A4-BA0-032-41-ST-VN



Each sensor consists of two parts: transmitter and receiver. When power is properly connected the power supply indicator (green LED) on the transmitter is constantly on.

The receiver has two indicators:

Stable operation indicator (green LED) turns on with a stable incoming beam and with a stable blocked light. Output indicator (orange LED) turns on when the beam from emitter is blocked by the float.

TROUBLESHOOTING		
PROBLEM	CAUSE	CHECK & ACTION
All indicators are off.	The power supply is not connected.	Connect the power supply.
The output indicators turn on and off but output does not turn on or off.	Incorrect wiring.	Check the wiring for the output wires.
	The input device has failed.	Try connecting the sensor output to a separate input device.
	Sensor output has failed or an output wire is broken.	
The output indicator is flashing.	Overcurrent has passed through an output.	Check that the rated current for the input device has not exceeded 50 mA.
		Check that the output wires are not shorted by any other wires.
	The sensor is affected by ambient light.	When there are light sources nearby (sensors, lighting), adjust the sensor installation.

SPECIFICATIONS	
MODE OF DETECTION	Red LED Thrubeam type.
POWER REQUIREMENTS	10 to 30 Vdc @50 mA max.
OUTPUT TRANSISTORS	NPN source up to 50 mA.
RESPONSE TIME	0.5 ms.
LIGHT IMMUNITY	4 Element, point light source, red LED 650 nm.
AMBIENT TEMPERATURE	25 degree C to +55 degree C.
SENSOR CONSTRUCTION	Heavy duty metal housing, IP-67 protection.
SENSOR CERTIFICATION	
UL	File #: E301717; Category: NRKH2/NRKH8; Enclosure type: 1 (UL50)
CE:EMC DIRECTIVE (2004/108/EC)	Applicable Standard: EMI: EN60947-5-2 Class A/EMS:EN60947-5-2

Configure and Order Online: [Optical Sensor Switch for Rotameters \(Single\)](#)
[Optical Sensor Switch for Rotameters \(Double\)](#)

ORDERING INFORMATION FOR OPTICAL SENSOR SWITCH ACCESSORY	
PART NUMBER	DESCRIPTION
OSV2-6-P	Hi-Lo Optical Sensor Switch for 65mm P Style Meter
OSV2-1-P	Hi-Lo Optical Sensor Switch for 150mm P Style Meter
OSV2-6-S	Hi-Lo Optical Sensor Switch for 65mm S Style Meter
OSV2-1-S	Hi-Lo Optical Sensor Switch for 150mm S Style Meter
OSV2-6-T	Hi-Lo Optical Sensor Switch for 65mm T Style Meter
OSV2-1-T	Hi-Lo Optical Sensor Switch for 150mm T Style Meter

PR-M

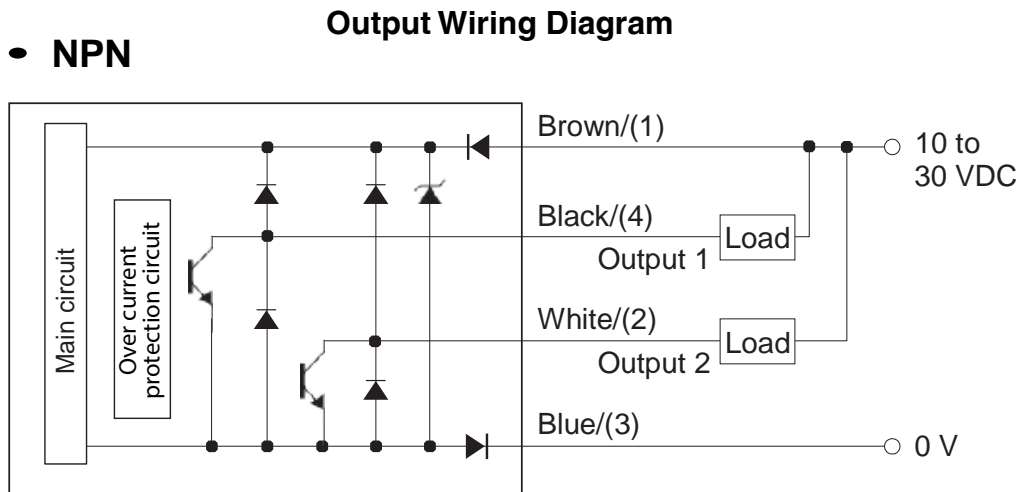
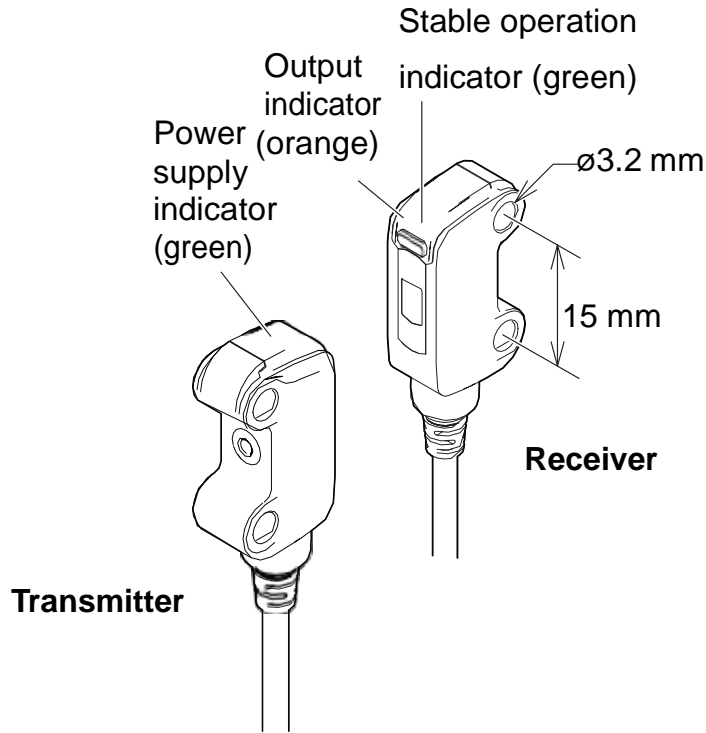

OPTICAL SENSOR SWITCH CONNECTION

WIRE LEAD COLOR	CONNECTION
BLACK	Positive Power Lead (+10 to 30 VDC)
YELLOW	Negative Power Lead
GREEN	NPN output #1
RED	NPN output #2 (Complementary to Output #1)

MOMENTARY OR LATCH OPERATION

Optionally the, Hi-Lo Optical Sensor Switch could be supplied with OSSM Module, allowing each sensor to be separately set for momentary or latch operation of buzzer, LED and relay.

The OSSM module is equipped with the 8 position DIP switch and requires a +12 VDC power supply with a minimum current rating of 250 mA.

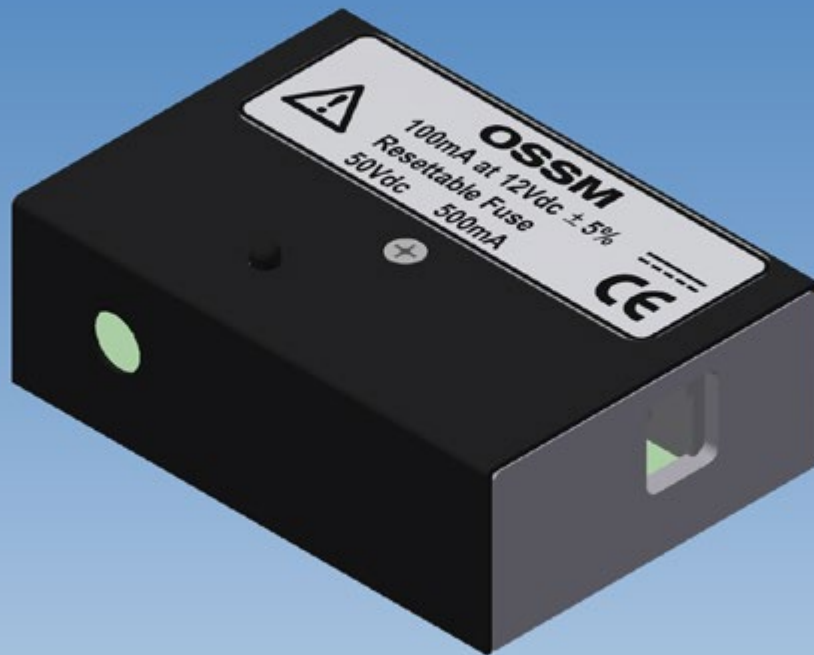



Gas Proportioner with CV™ valve
for blending two gases

To blend two or three gases in homogeneous infinitely variable concentrations, directly at the end use point, this Model G gas proportioner is unsurpassed in convenience and economy.

Gas proportioners pay for themselves since they eliminate the need for expensive custom blended gas mixtures.

They lend flexibility and economy to the utilization of component gas cylinders and "piped-in" supply lines.

**Another advantage
in laboratory investigations is
the freedom to reproducibility
increase or decrease
concentrations during
the course of an experiment.**

The flow rates are not affected by downstream pressure variations as long as back pressures do not approach or exceed the input pressure. Input pressures of up to 200 psig (13.8 bars) can be used; however, customers' very often find 50 psig (3.45 bars) a convenient setting to work with.

design features

- ✓ Blending of two or three gases with gas proportioners obviates the need for:
 - ✓ ORDERING FIXED GAS MIXTURES.
 - ✓ CONTAMINATION FROM REUSABLE GAS CYLINDERS.
 - ✓ POTENTIALLY INACCURATE MIXTURES BY GAS SUPPLIERS.
- ✓ Rib-guided or fluted metering tubes facilitate stable, accurate readings.
- ✓ OPTIGRAD™ scales minimize parallax and eye fatigue.
- ✓ Interchangeability of flow tubes and floats.
- ✓ Simple means of panel mounting.

BUILT-IN VALVES

Meters are available with built-in needle valves (CV™), high precision metering valves (MFV™) with “non-rising stems”, or with no valves.

The higher cost of MFV™ valves is justified whenever high sensitivity control and resolution are desirable particularly in conjunction with metering tubes of very low flow rates.

design features

- ✓ Precision fabricated from heavy walled, shock resistant borosilicate glass.
- ✓ Bores are uniformly tapered or formed with internal “rib-guides” or flutes.
- ✓ Floats are retained by TFE plugs.
- ✓ Self cleaning.
- ✓ Low differential pressures that stay independent of flow rate changes.

DIMENSIONS FOR G STYLE METERS

SCALE LENGTH	WIDTH (W)	
	2 CHANNEL	3 CHANNEL
150 mm	3.24	4.23

Bench mounting acrylic tripod bases are optional.

DIMENSIONS

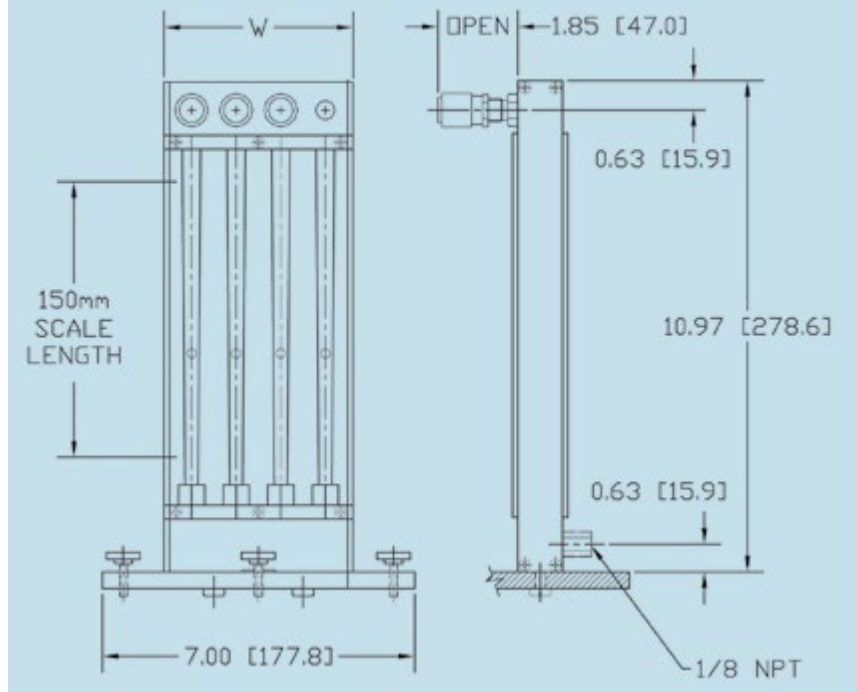

NOTE: Aalborg® reserves the right to change designs and dimensions at its sole discretion at any time without notice. For certified dimensions please contact Aalborg®.

SPECIFICATIONS STANDARD COMPONENT

FLOW TUBE ACCURACY

±2% FS mm scales except 042 and 032 flow tubes ±5%, from 10 to 100% of scale. Conforming to ISA RP. 16-1.2.3. Specification 2-S-10.

COMPONENT FLOW TUBE REPEATABILITY

±0.25%. Typical calibration curves for air at 50 psig /3.5 bars using glass floats are available. Consult the company on the availability of calibration data for non-hazardous gases and special individual calibrations.

MAX OPERATING PRESSURE 200 psig/13.8 bars.

MAX OPERATING TEMPERATURE 250 °F/ 121 °C.

**MATERIALS OF CONSTRUCTION

FLOW TUBES Heavy walled borosilicate glass.

CHOICE OF MOUNTING FITTINGS IN CONTACT WITH GASES

a) Aluminum, black anodized. b) 316 stainless steel.

SIDE PANELS Aluminum, black anodized.

FRONT SHIELD Clear polycarbonate.

BACK PLATE 1/8" thick white acrylics.

O-RINGS AND PACKING Buna® O-rings in aluminum model.

FKM, O-rings in stainless steel meters.

OPTIONAL FKM, PTFE/FFKM/EPR.

CONNECTIONS 1/8" NPT female inlet and outlet connections.

OPTIONAL Hose and compression fittings are available.

***The selection of materials of construction, is the responsibility of the customer. The company accepts no liability.*

Ordering information see page 38.

For flow capacities see table 10 page 64.

G

ORDERING INFORMATION G STYLE METER

Configure and Order Online: [Model G Gas Proportioner Meters](#)

CODE	
G	G STYLE METERS
CODE	TUBE QUANTITIES
2	TWO CHANNEL METER (TWO TUBES AND ONE MIXING TUBE)
3	THREE CHANNEL METER (THREE TUBES AND ONE MIXING TUBE)
CODE	SIZE
1	150 mm
CODE	MATERIAL
A	ALUMINUM
S	STAINLESS
CODE	VALVE
5	MFV (HIGH PRECISION) INLET
6	CV OUTLET (STANDARD CARTRIDGE)
CODE	SEALS
V	FKM STD ON STAINLESS METERS
B	BUNA® STD ON BRASS AND ALUMINUM
E	EPR
T	PTFE
CODE	FITTINGS
A	1/8" FNPT
B	1/4" FNPT
C	1/8" HOSE NIPPLE
D	1/4" HOSE NIPPLE
E	1/8" COMPRESSION
F	1/4" COMPRESSION
H	VCR
CODE	MANIFOLD
0	NONE

G 2 1 A 6 — B A 0 — *TUBE

EXAMPLE: G21A6-BA0

G-Style Meters, Two Channels, 150mm, Aluminum, CV Outlet, Buna Seals, 1/8" FNPT fittings, No Manifold.

Optional Accessories

TPG-Tripod for 2 channel gas proportioner.
TPH-Tripod for 3 channel gas proportioner.

*Tube selection:

Millimeter tubes: Table 10.

Designed especially for the laboratory these kits offer a diverse economical way of acquiring flow measurement capabilities. Since all 150 mm flow tubes in this catalog are interchangeable, additional flow tubes may be added later (see flow tables, pages 61 to 64). A handy selection of flow meters is presented in kit form.

THREE TYPES OF KITS ARE OFFERED

- Aluminum Flow Meter Kit.
- Stainless Steel Flow Meter Kit.
- PTFE Flow Meter Kit.

Kits are shipped in convenient molded plastic carrying cases. Flow tubes and floats are interchangeable in frames supplied facilitating overlapping flow ranges.

For non-corrosive fluids use the Aluminum Kit.
For corrosives consider the Stainless Steel Kit.
For corrosive applications at lower pressure or for high purity fluid service specify the PTFE Kit.

All three units are supplied with glass floats installed.

Aluminum and Stainless Steel kits come with spare stainless steel and tantalum interchangeable floats to extend flow capacities. Due to chemical compatibility considerations PTFE kits are supplied with spare sapphire floats.



KIT-S1A-BAA Aluminum Kit Shown

FLOW CAPACITIES OF FLOW TUBES USED IN KITS [mL/min]

FLOW TUBE NUMBER	FLOAT MATERIAL					
	GLASS		SAPPHIRE		STAINLESS STEEL	
	AIR	WATER	AIR	WATER	AIR	WATER
042-15	1.8 to 18.9	0.02 to 0.19	2.9 to 30	.04 to .38	5.8 to 60.6	0.09 to .945
112-02	21 to 374	.023 to 5.5	29 to 513	.39 to 9.96	36 to 814	1.1 to 20.4
102-05	135 to 3922	2 to 84	198 to 5188	3 to 126	351 to 7825	6 to 217
044-40	791 to 23742	15 to 541	1208 to 30711	30 to 806	2182 to 45227	57 to 1288

Configure and Order Online: [Flow Meter Kits](#)

ORDERING INFORMATION FOR FLOW METER KITS

MODEL NUMBER	CONTENTS	DESCRIPTION
KIT-S1A-BA	ALUMINUM FLOW METER KIT: Assembled with 042-15-GL flow tube. Extra flow tubes as listed in above table. Stainless steel float for 042, 112 and 102 flow tubes. Tantalum float for 044 flow tube. High flow valve cartridge. Tripod base, tweezers, pushrod and locking tool for changing floats and flow tubes. Calibration data and carrying case.	Wetted parts are borosilicate glass, aluminum, 316 stainless steel. Buna® o-rings and FKM packings.
KIT-S1S-VA	STAINLESS STEEL FLOW METER KITS: Assembled with 042-15-GL flow tube. Extra flow tubes as listed in above table. Stainless steel float for 042, 112 and 102 flow tubes. Tantalum float for 044 flow tube. High flow valve cartridge. Tripod base, tweezers, pushrod and locking tool for changing floats and flow tubes. Calibration data and carrying case.	Wetted parts are borosilicate glass, 316 stainless steel, FKM o-rings and packings.
KIT-T1T-TA	PTFE FLOW METER KIT: Assembled with 042-15-GL flow tube. Extra flow tubes as listed in above table. Sapphire floats. High flow valve cartridge. Tripod base, tweezers, pushrod and locking tool for changing floats and flow tubes. Calibration data and carrying case.	Wetted parts are borosilicate glass, PTFE and PEEK.

V

MEDIUM RANGE BRASS AND STAINLESS FLOW METERS

Incorporating traditional rotameter precision glass technology, these rugged brass and stainless steel flow meters offer accurate and economical solutions to medium flow range measurements. **V meters** are designed with unique rotatable scales of dual air-water direct reading graduations showing SCFM and L/min (air), as well as GPM and LPM (water) markings.

design features

- ✓ Rigid, compact construction.
- ✓ Dual, rotatable direct reading scales for air and water.
- ✓ Graduations reflect both metric and English systems.
- ✓ Vertical In-line or Panel Mount.
- ✓ Flow ranges from 4 to 20 L/min water and 140 to 900 L/min air.

SPECIFICATIONS

SCALES	Rotatable, direct reading air, (SCFM-L/min) and water (GPM-LPM).
ACCURACY	±5% of full scale.
MAXIMUM TEMPERATURE	250 °F (121 °C).
MAXIMUM PRESSURE	150 psig (@ 200 °F).
CONNECTIONS	3/8" NPT female in line or horizontal rear.

**MATERIALS OF CONSTRUCTION

TUBE SHIELDS	Polycarbonate.
FLOW TUBES	Heavy walled precision formed borosilicate glass.
FLOATS	Type 316 stainless steel.
WETTED PARTS	Brass or type 316 stainless steel.
SEALS	FKM standard.
OPTIONAL	FKM, PTFE/FFKM/EPR.

**The selection of materials of construction, is the responsibility of the customer. The company accepts no liability.

Ordering information see page 42.

DIMENSIONS (IN LINE MODEL)

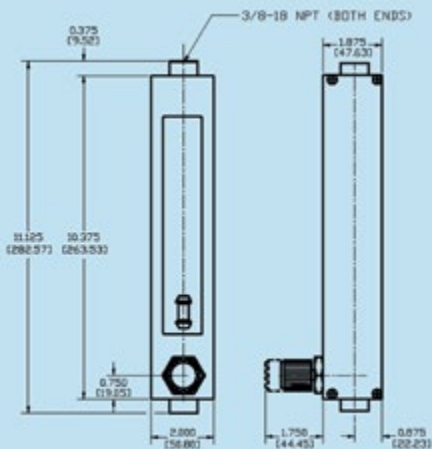

Panel Mount Meter with Valve

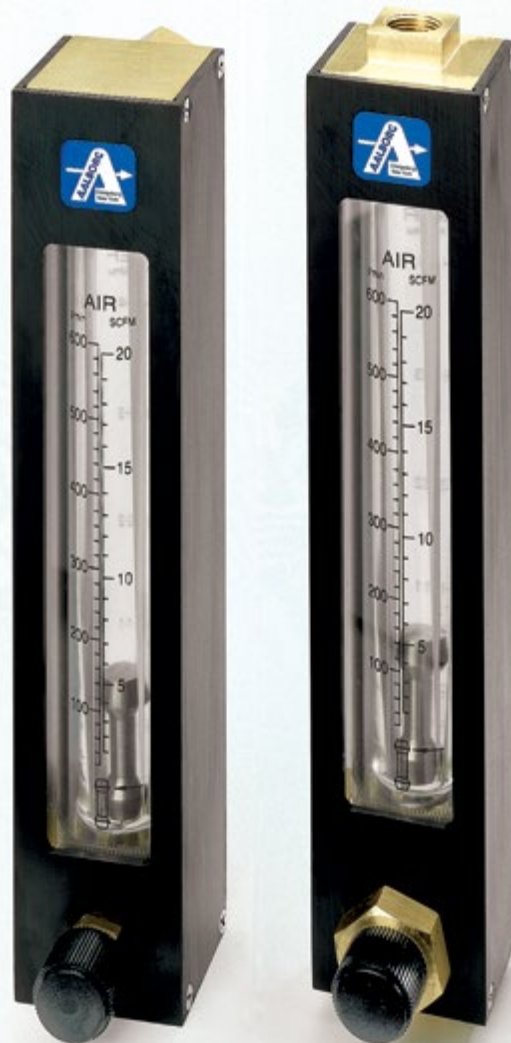

In-line Meter with Valve

DIMENSIONS (PANEL MOUNT MODEL)

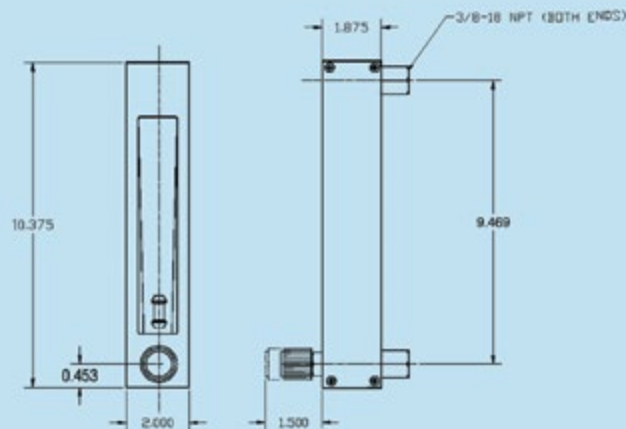

NOTE: Aalborg® reserves the right to change designs and dimensions at its sole discretion at any time without notice. For certified dimensions please contact Aalborg®.



Incorporating traditional variable area precision glass technology, these rugged PTFE flow meters offer accurate and economical solutions to medium flow range measurements. **V meters** are designed with unique rotatable scales of dual air-water direct reading graduations showing SCFM and L/min (air), as well as GPM and LPM (water) markings.

LEAK INTEGRITY

Flow meters are individually tested on a Mass Spectrometer Leak Detector and certified to a leak integrity rating of 1×10^{-7} sccs Helium or better.

SPECIFICATIONS

SCALES	Rotatable, direct reading air, (SCFM-L/min) and water (GPM-LPM). Scale length is 127mm (nominal).
ACCURACY	±5% of full scale.
MAXIMUM TEMPERATURE	150 °F (65 °C.)
MAXIMUM PRESSURE	100 psig (6.7) bars.
CONNECTIONS	3/8" NPT female in line or horizontal rear.
LEAK INTEGRITY	Individually leak tested and certified.

**MATERIALS OF CONSTRUCTION

TUBE SHIELDS	Polycarbonate.
FLOW TUBES	Heavy walled precision formed borosilicate glass.
FLOATS	PTFE.
WETTED PARTS	PTFE and PEEK.
SEALS	PTFE.

**The selection of materials of construction, is the responsibility of the customer. The company accepts no liability.

Ordering information see page 42.



DIMENSIONS (IN LINE MODEL)

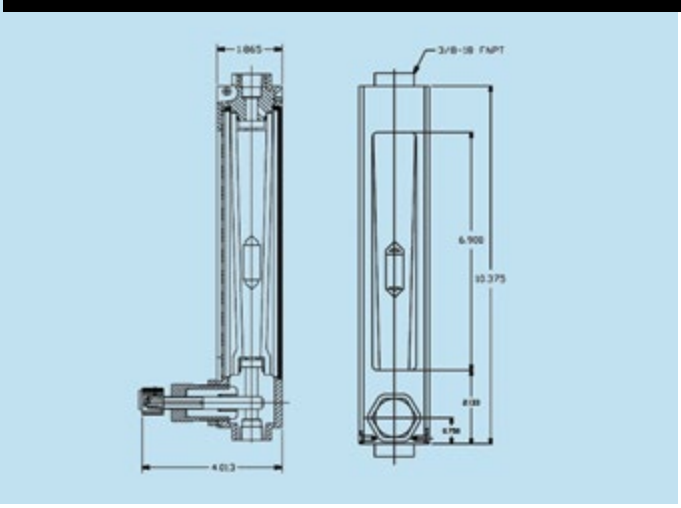

DIMENSIONS (PANEL MOUNT MODEL)

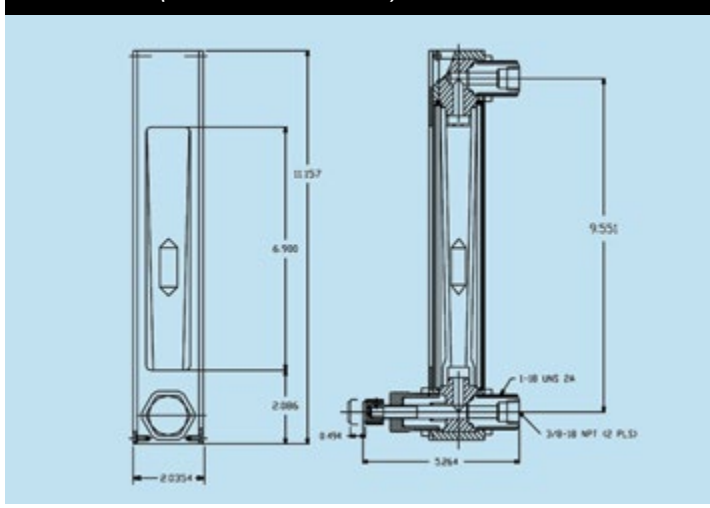

NOTE: Aalborg® reserves the right to change designs and dimensions at its sole discretion at any time without notice. For certified dimensions please contact Aalborg®.

NOTE: Aalborg® reserves the right to change designs and dimensions at its sole discretion at any time without notice. For certified dimensions please contact Aalborg®.



ORDERING INFORMATION MEDIUM RANGE FLOW METERS

Configure and Order Online: [Model V Medium Range Flow Meters](#)

VERTICAL IN LINE						
MODEL NUMBER		END FITTING MATERIAL	MAXIMUM FLOW			
BUILT IN VALVE	NO VALVE		Air		Water	
			SCFM	L/min	GPM	LPM
VIB4-VA-V01-01-ST	VPB3-VA-V01-02-ST	Brass	5	140	1.2	4
VIB4-VA-V02-01-ST	VIB3-VA-V02-01-ST	Brass	10	280	2	8
VIB4-VA-V03-01-ST	VIB3-VA-V03-01-ST	Brass	15	425	3	11.5
VIB4-VA-V04-01-ST	VIB3-VA-V04-01-ST	Brass	20	575	4	15
VIB4-VA-V05-01-ST	VIB3-VA-V05-01-ST	Brass	30	900	5	20
VIS4-VA-V01-01-ST	VIS3-VA-V01-01-ST	316 s.s	5	140	1.2	4
VIS4-VA-V02-01-ST	VIS3-VA-V02-01-ST	316 s.s	10	280	2	8
VIS4-VA-V03-01-ST	VIS3-VA-V03-01-ST	316 s.s	15	425	3	11.5
VIS4-VA-V04-01-ST	VIS3-VA-V04-01-ST	316 s.s	20	575	4	15
VIS4-VA-V05-01-ST	VIS3-VA-V05-01-ST	316 s.s	30	900	5	20

PANEL MOUNT METERS						
MODEL NUMBER		END FITTING MATERIAL	MAXIMUM FLOW			
BUILT IN VALVE	NO VALVE		Air		Water	
			SCFM	L/min	GPM	LPM
VPB4-VA-V01-02-ST	VPB3-VA-V01-02-ST	Brass	5	140	1.2	4
VPB4-VA-V02-02-ST	VPB3-VA-V02-02-ST	Brass	10	280	2	8
VPB4-VA-V03-02-ST	VPB3-VA-V03-02-ST	Brass	15	425	3	11.5
VPB4-VA-V04-02-ST	VPB3-VA-V04-02-ST	Brass	20	600	4	15
VPB4-VA-V05-02-ST	VPB3-VA-V05-02-ST	Brass	30	900	5	20
VPS4-VA-V01-02-ST	VPS3-VA-V01-02-ST	316 s.s	5	140	1.2	4
VPS4-VA-V02-02-ST	VPS3-VA-V02-02-ST	316 s.s	10	280	2	8
VPS4-VA-V03-02-ST	VPS3-VA-V03-02-ST	316 s.s	15	425	3	11.5
VPS4-VA-V04-02-ST	VPS3-VA-V04-02-ST	316 s.s	20	600	4	15
VPS4-VA-V05-02-ST	VPS3-VA-V05-02-ST	316 s.s	30	900	5	20

PTFE VERTICAL IN LINE METERS						
MODEL NUMBER		END FITTING MATERIAL	MAXIMUM FLOW			
BUILT IN VALVE	NO VALVE		Air		Water	
			SCFM	L/min	GPM	LPM
VIT4-TA-V06-01-TF	VIT3-TA-V06-01-TF	PTFE	3.5	100	0.8	3
VIT4-TA-V07-01-TF	VIT3-TA-V07-01-TF	PTFE	7	200	1.5	5.75
VIT4-TA-V08-01-TF	VIT3-TA-V08-01-TF	PTFE	10.5	300	2.2	8.25
VIT4-TA-V09-01-TF	VIT3-TA-V09-01-TF	PTFE	14	400	2.9	11
VIT4-TA-V10-01-TF	VIT3-TA-V10-01-TF	PTFE	17.5	500	3.5	13.25
VIT4-TA-V11-01-TF	VIT3-TA-V11-01-TF	PTFE	22	625	4.1	16

PTFE PANEL MOUNT METERS						
MODEL NUMBER		END FITTING MATERIAL	MAXIMUM FLOW			
BUILT IN VALVE	NO VALVE		Air		Water	
			SCFM	L/min	GPM	LPM
VPT4-TA-V06-02-TF	VPT3-TA-V06-02-TF	PTFE	3.5	100	0.8	3
VPT4-TA-V07-02-TF	VPT3-TA-V07-02-TF	PTFE	7	200	1.5	5.75
VPT4-TA-V08-02-TF	VPT3-TA-V08-02-TF	PTFE	10.5	300	2.2	8.25
VPT4-TA-V09-02-TF	VPT3-TA-V09-02-TF	PTFE	14	400	2.9	11
VPT4-TA-V10-02-TF	VPT3-TA-V10-02-TF	PTFE	17.5	500	3.5	13.25
VPT4-TA-V11-02-TF	VPT3-TA-V11-02-TF	PTFE	22	625	4.1	16

Incorporating traditional rotameter precision glass technology, these rugged brass and stainless steel flow meters offer accurate and economical solutions to medium flow range measurements.

xV meters are designed with unique rotatable scales in either SCFM or L/min. Each features direct reading scales for 5 gases. (Argon, CO₂, He, N₂, & O₂).

design features

- ✓ Rigid, compact construction.
- ✓ Multi-gas, rotatable direct reading scales for 5 gases.
- ✓ Graduations reflect metric or English systems.
- ✓ Vertical In-line or Panel Mount.

SPECIFICATIONS

SCALES	Rotatable, direct reading Argon, CO ₂ , He, N ₂ , & O ₂ .
ACCURACY	±5% of full scale.
MAXIMUM TEMPERATURE	250 °F (121 °C).
MAXIMUM PRESSURE	150 psig (@ 200 °F).
CONNECTIONS	3/8" NPT female in line or horizontal rear.

**MATERIALS OF CONSTRUCTION

TUBE SHIELDS	Polycarbonate.
FLOW TUBES	Heavy walled precision formed borosilicate glass.
FLOATS	Type 316 stainless steel.
WETTED PARTS	Brass or type 316 stainless steel.
SEALS	FKM standard.
OPTIONAL:	Buna®, PTFE /FFKM and EPR.

**The selection of materials of construction, is the responsibility of the customer. The company accepts no liability.

DIMENSIONS (IN LINE MODEL)

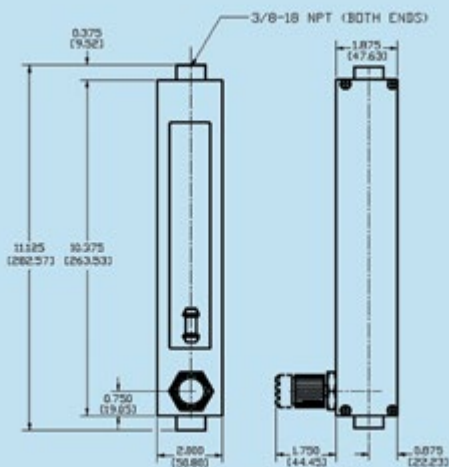

DIMENSIONS (PANEL MOUNT MODEL)

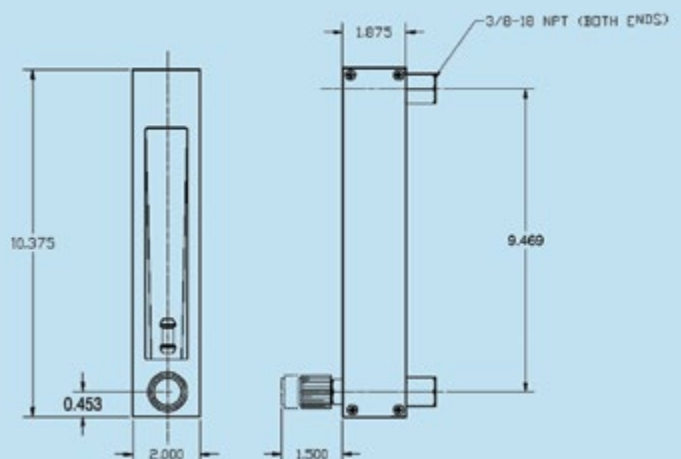

NOTE: Aalborg® reserves the right to change designs and dimensions at its sole discretion at any time without notice. For certified dimensions please contact Aalborg®.



ORDERING INFORMATION MEDIUM RANGE FLOW METERS

Configure and Order Online: [Model xV Medium Range Flow Meters](#)

VERTICAL IN LINE							
MODEL NUMBER		END FITTING MATERIAL	MAXIMUM FLOW				
BUILT IN VALVE	NO VALVE		SCFM				
			Argon	CO2	Helium	Nitrogen	Oxygen
VIB4-VA-V01-03-ST	VIB3-VA-V01-03-ST	Brass	4.2	3.8	12.0	4.5	4.5
VIB4-VA-V02-03-ST	VIB3-VA-V02-03-ST	Brass	8.0	8.0	23.0	9.5	9.0
VIB4-VA-V03-03-ST	VIB3-VA-V03-03-ST	Brass	12.5	12.5	35.0	14.0	14.0
VIB4-VA-V04-03-ST	VIB3-VA-V04-03-ST	Brass	15.5	15.5	42.5	19.0	18.0
VIB4-VA-V05-03-ST	VIB3-VA-V05-03-ST	Brass	26.0	24.0	60.0	30.0	28.0
VIS4-VA-V01-03-ST	VIS3-VA-V01-03-ST	316 s.s	4.2	3.8	12.0	4.5	4.5
VIS4-VA-V02-03-ST	VIS3-VA-V02-03-ST	316 s.s	8.0	8.0	23.0	9.5	9.0
VIS4-VA-V03-03-ST	VIS3-VA-V03-03-ST	316 s.s	12.5	12.5	35.0	14.0	14.0
VIS4-VA-V04-03-ST	VIS3-VA-V04-03-ST	316 s.s	15.5	15.5	42.5	19.0	18.0
VIS4-VA-V05-03-ST	VIS3-VA-V05-03-ST	316 s.s	26.0	24.0	60.0	30.0	28.0

VERTICAL IN LINE							
MODEL NUMBER		END FITTING MATERIAL	MAXIMUM FLOW				
BUILT IN VALVE	NO VALVE		L/min				
			Argon	CO2	Helium	Nitrogen	Oxygen
VIB4-VA-V01-05-ST	VIB3-VA-V01-05-ST	Brass	120	105	350	130	130
VIB4-VA-V02-05-ST	VIB3-VA-V02-05-ST	Brass	230	220	650	270	260
VIB4-VA-V03-05-ST	VIB3-VA-V03-05-ST	Brass	360	360	1000	400	400
VIB4-VA-V04-05-ST	VIB3-VA-V04-05-ST	Brass	440	440	1250	550	525
VIB4-VA-V05-05-ST	VIB3-VA-V05-05-ST	Brass	750	700	1800	850	800
VIS4-VA-V01-05-ST	VIS3-VA-V01-05-ST	316 s.s	120	105	350	130	130
VIS4-VA-V02-05-ST	VIS3-VA-V02-05-ST	316 s.s	230	220	650	270	260
VIS4-VA-V03-05-ST	VIS3-VA-V03-05-ST	316 s.s	360	360	1000	400	400
VIS4-VA-V04-05-ST	VIS3-VA-V04-05-ST	316 s.s	440	440	1250	550	525
VIS4-VA-V05-05-ST	VIS3-VA-V05-05-ST	316 s.s	750	700	1800	850	800

PANEL MOUNT METERS							
MODEL NUMBER		END FITTING MATERIAL	MAXIMUM FLOW				
BUILT IN VALVE	NO VALVE		SCFM				
			Argon	CO2	Helium	Nitrogen	Oxygen
VPB4-VA-V01-04-ST	VPB3-VA-V01-04-ST	Brass	4.2	3.8	12.0	4.5	4.5
VPB4-VA-V02-04-ST	VPB3-VA-V02-04-ST	Brass	8.0	8.0	23.0	9.5	9.0
VPB4-VA-V03-04-ST	VPB3-VA-V03-04-ST	Brass	12.5	12.5	35.0	14.0	14.0
VPB4-VA-V04-04-ST	VPB3-VA-V04-04-ST	Brass	15.5	15.5	42.5	19.0	18.0
VPB4-VA-V05-04-ST	VPB3-VA-V05-04-ST	Brass	26.0	24.0	60.0	30.0	28.0
VPS4-VA-V01-04-ST	VPS3-VA-V01-04-ST	316 s.s	4.2	3.8	12.0	4.5	4.5
VPS4-VA-V02-04-ST	VPS3-VA-V02-04-ST	316 s.s	8.0	8.0	23.0	9.5	9.0
VPS4-VA-V03-04-ST	VPS3-VA-V03-04-ST	316 s.s	12.5	12.5	35.0	14.0	14.0
VPS4-VA-V04-04-ST	VPS3-VA-V04-04-ST	316 s.s	15.5	15.5	42.5	19.0	18.0
VPS4-VA-V05-04-ST	VPS3-VA-V05-04-ST	316 s.s	26.0	24.0	60.0	30.0	28.0

PANEL MOUNT METERS							
MODEL NUMBER		END FITTING MATERIAL	MAXIMUM FLOW				
BUILT IN VALVE	NO VALVE		L/min				
			Argon	CO2	Helium	Nitrogen	Oxygen
VPB4-VA-V01-06-ST	VPB3-VA-V01-06-ST	Brass	120	105	350	130	130
VPB4-VA-V02-06-ST	VPB3-VA-V02-06-ST	Brass	230	220	650	270	260
VPB4-VA-V03-06-ST	VPB3-VA-V03-06-ST	Brass	360	360	1000	400	400
VPB4-VA-V04-06-ST	VPB3-VA-V04-06-ST	Brass	440	440	1250	550	525
VPB4-VA-V05-06-ST	VPB3-VA-V05-06-ST	Brass	750	700	1800	850	800
VPS4-VA-V01-06-ST	VPS3-VA-V01-06-ST	316 s.s	120	105	350	130	130
VPS4-VA-V02-06-ST	VPS3-VA-V02-06-ST	316 s.s	230	220	650	270	260
VPS4-VA-V03-06-ST	VPS3-VA-V03-06-ST	316 s.s	360	360	1000	400	400
VPS4-VA-V04-06-ST	VPS3-VA-V04-06-ST	316 s.s	440	440	1250	550	525
VPS4-VA-V05-06-ST	VPS3-VA-V05-06-ST	316 s.s	750	700	1800	850	800

design features

- ✓ Heavy duty stainless steel.
- ✓ Thick polycarbonate safety shields.
- ✓ Fluted or plain tapered tubes.
- ✓ Direct reading metric and English system scales.
- ✓ Unique design facilitates ease of maintenance cleaning processes.

Heavy-duty flow meters are fully enclosed in a brushed stainless steel case. Ideal for industrial applications with flow rates of up to 116 GPM / 440 L/min and 250 SCFM / 7080 L/min. Used for flow measurements of liquids (water) and gases (air).



Flanged
M Style Meter

Meters are graduated for direct reading of water and air. Flow meters come with FNPT or flanged end fittings for easy in-line installation. Wetted parts include borosilicate glass flow tubes, FKM o-rings, and 316 Stainless steel fittings, guide rods, floats and float stops.

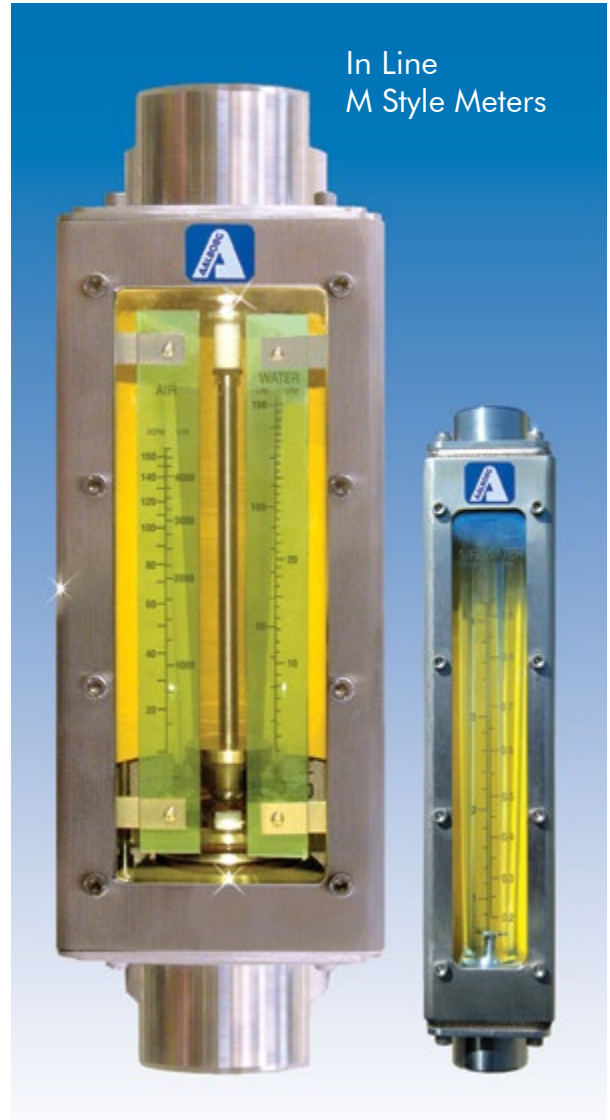

SPECIFICATIONS

ACCURACY	±3% of full scale.
MINIMUM FLOW RATE	Approximately 10% of maximum flow rate.
REPEATABILITY	±0.5% of full scale.
MAXIMUM PRESSURE AT 200 °F (93 °C)	200 PSIG / 13.6 bar gauge (tube size 3, 4, 5 and 6). 125 PSIG / 8.5 bar gauge (tube SIZE 8 and 9).
MAXIMUM OPERATING TEMPERATURE	200 °F (93 °C).

**MATERIALS OF CONSTRUCTION

FLOW TUBES	Heavy walled borosilicate glass.
FITTINGS IN CONTACT WITH FLUIDS	316 Stainless Steel.
FRONT SHIELD	Thick clear polycarbonate and white acrylics.
O-RINGS	FKM.
OPTIONAL	PTFE/ FFKM, EPR.
CONNECTIONS	IN LINE: 1/2", 1-1/2", 2", NPT. 150 ANSI FLANGED: 3/4", 1-1/2", 2-1/2".

***The selection of materials of construction, is the responsibility of the customer. The company accepts no liability.*

M

ORDERING INFORMATION STAINLESS INDUSTRIAL FLOW METERS

Configure and Order Online: [Model M Industrial Flow Meters](#)

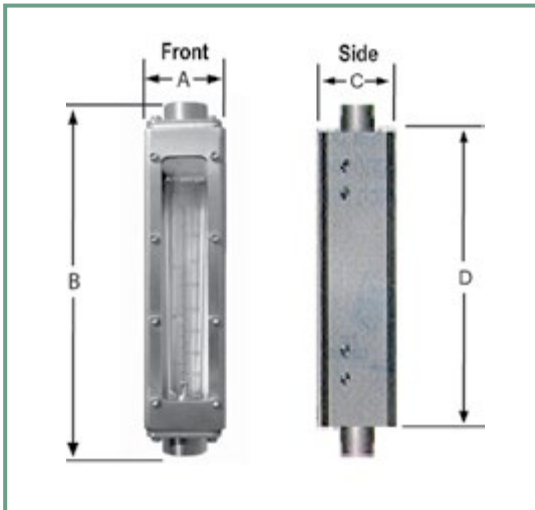

DIMENSIONS FOR IN-LINE M STYLE METERS

NPT (F)	A	B	C	D
1/2"	2	9.54	2.25	8.04
1"	3.5	13.69	3.75	10.50
2"	5	15.59	5.25	11.55

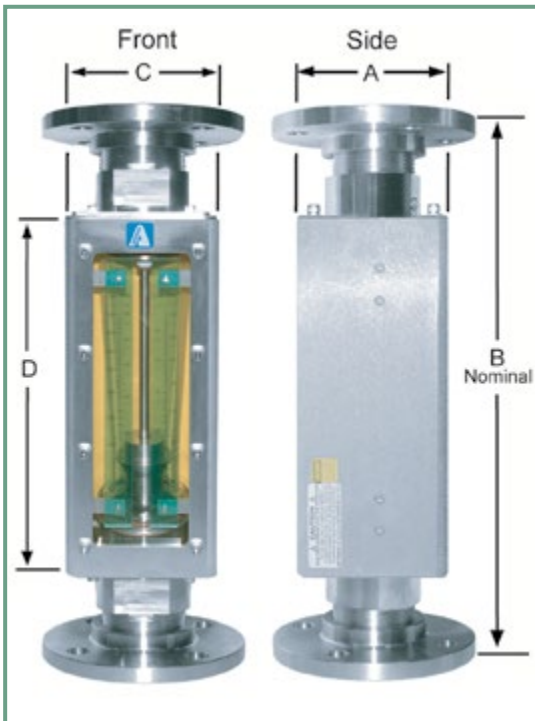

DIMENSIONS FOR FLANGED M STYLE METERS

Flange Size	A	B (Nominal)	C	D
3/4"	2	9.58	2.25	8.04
1 1/2"	3.5	14.15	3.75	10.50
2 1/2"	5	17.98	5.25	11.55

IN LINE M STYLE METERS

CATALOG NUMBER	MAX FLOW RATE				PRESSURE DROP (OF H ₂ O)	TUBE SIZE	NPT CONNECTION
	WATER [GPM]	AIR [SCFM]	WATER [L/min]	AIR [L/min]			
MS-VJ-M01-02-ST	0.25	1.2	.95	35	3	3	1/2"
MS-VJ-M02-02-ST	0.36	1.9	1.3	54	3	3	
MS-VJ-M03-02-ST	0.76	3.3	3.0	90	7	3	
MS-VJ-M04-02-ST	1.0	4.2	3.8	120	8	4	
MS-VJ-M05-02-ST	1.5	6.5	5.6	180	11	4	
MS-VJ-M06-02-ST	2.2	8.5	8.2	250	14	4	
MS-VK-M07-02-ST	3.8	16	14	480	14	5	1"
MS-VK-M08-02-ST	5.0	22	18	650	20	5	
MS-VK-M09-02-ST	6.0	25	22	725	7	6	
MS-VK-M10-02-ST	7.4	34	27.5	950	8	6	
MS-VK-M11-02-ST	9.6	40	36	1200	14	6	
MS-VK-M12-02-ST	11	47.5	42	1400	18	6	
MS-VK-M13-02-ST	15	62.5	52.5	1800	34	6	2"
MS-VK-M14-02-ST	20	90	80	2600	55	6	
MS-VL-M15-02-ST	22	90	85	2550	23	8	2"
MS-VK-M16-02-ST	25	-	95	-	99	6	1"
MS-VQ-M17-02-ST	41	170	155	4600	7	9	2"
MS-VL-M18-02-ST	44	180	165	5000	42	8	
MS-VQ-M19-02-ST	60	250	230	7000	23	9	
MS-VL-M20-02-ST	62	250	230	7000	70	8	
MS-VQ-M21-02-ST	86	-	320	-	35	9	
MS-VQ-M22-02-ST	116	-	440	-	56	9	

FLANGED M STYLE METERS

CATALOG NUMBER	MAX FLOW RATE				PRESSURE DROP (OF H ₂ O)	TUBE SIZE	FLANGE CONNECTION
	WATER [GPM]	AIR [SCFM]	WATER [L/min]	AIR [L/min]			
MS-VR-M01-02-ST	0.25	1.2	.95	35	3	3	3/4"
MS-VR-M02-02-ST	0.36	1.9	1.3	54	3	3	
MS-VR-M03-02-ST	0.76	3.3	3.0	90	7	3	
MS-VR-M04-02-ST	1.0	4.2	3.8	120	8	4	
MS-VR-M05-02-ST	1.5	6.5	5.6	180	11	4	
MS-VR-M06-02-ST	2.2	8.5	8.2	250	14	4	
MS-VS-M07-02-ST	3.8	16	14	480	14	5	1 1/2"
MS-VS-M08-02-ST	5.0	22	18	650	20	5	
MS-VS-M09-02-ST	6.0	25	22	725	7	6	
MS-VS-M10-02-ST	7.4	34	27.5	950	8	6	
MS-VS-M11-02-ST	9.6	40	36	1200	14	6	
MS-VS-M12-02-ST	11	47.5	42	1400	18	6	
MS-VS-M13-02-ST	15	62.5	52.5	1800	34	6	2 1/2"
MS-VS-M14-02-ST	20	90	80	2600	55	6	
MS-VT-M15-02-ST	22	90	85	2550	23	8	1 1/2"
MS-VS-M16-02-ST	25	-	95	-	99	6	1 1/2"
MS-VU-M17-02-ST	41	170	155	4600	7	9	2 1/2"
MS-VT-M18-02-ST	44	180	165	5000	42	8	
MS-VU-M19-02-ST	60	250	230	7000	23	9	
MS-VT-M20-02-ST	62	250	230	7000	70	8	
MS-VU-M21-02-ST	86	-	320	-	35	9	
MS-VU-M22-02-ST	116	-	440	-	56	9	

NOTE: Aalborg® reserves the right to change designs and dimensions at its sole discretion at any time without notice. For certified dimensions please contact Aalborg®.
47 WWW.AALBORG.COM ● E-MAIL ✉ INFO@AALBORG.COM ● PHONE ☎ 845.770.3000 ● TOLL FREE IN U.S.A. AND CANADA 1.800.866.3837 ● ORANBURG N.Y. U.S.A.

Made entirely of PTFE, PFA, and PCTFE, the Model F flow meter is excellent for high-purity applications or use with corrosive liquids.

Units are available with a standard valve to monitor and control flow or without a valve to just monitor flow.

Flow meters are individually tested on a Mass Spectrometer Leak Detector and certified to a leak integrity rating of 1×10^{-7} sccs Helium or better.

design features

- ✓ Chemically inert wetted components.
- ✓ Removable protective shield.
- ✓ Individually leak tested.

SPECIFICATIONS

SCALES	Direct reading scales for liquids with 1.0 specific gravity.
ACCURACY	±5% of full scale.
MAXIMUM TEMPERATURE	250 °F (121 °C).
MAXIMUM PRESSURE	100 psig (6.7 bars).
LEAK INTEGRITY	Individually, leak tested and certified to a rating of 1×10^{-7} sccs of Helium.

**MATERIALS OF CONSTRUCTION

TUBE SHIELDS	Polycarbonate.
FLOW TUBES	PFA.
FLOATS	PTFE.
WETTED PARTS	PTFE end fittings. PCTFE guide rods.

***The selection of materials of construction, is the responsibility of the customer. The company accepts no liability.*



F

IN LINE PTFE FLOW METER

**F STYLE IN LINE PTFE FLOW METER
DIMENSIONS NO VALVE OPTION**

	A	B	C
F3C	1/4 FNPT	5.52" (140.2 mm)	1.25" (31.8 mm)
F3D	3/8 FNPT	5.52" (140.2 mm)	1.25" (31.8 mm)
F3E	1/2 FNPT	10.81" (274.6 mm)	2.00" (50.8 mm)
F3F	3/4 FNPT	10.81" (274.6 mm)	2.00" (50.8 mm)

**F STYLE IN LINE PTFE FLOW METER
DIMENSIONS VALVE OPTION**

	A	B	C	D	E
F6C	1/4 FNPT	6.65" (168.9 mm)	1.25" (31.8 mm)	1.25" (31.8 mm)	3.17" (80.5 mm)
F6D	3/8 FNPT	6.65" (168.9 mm)	1.25" (31.8 mm)	1.25" (31.8 mm)	3.17" (80.5 mm)
F6E	1/2 FNPT	12.35" (313.7 mm)	2.00" (50.8 mm)	2.00" (50.8 mm)	3.88" (98.5 mm)
F6F	3/4 FNPT	12.35" (313.7 mm)	2.00" (50.8 mm)	2.00" (50.8 mm)	3.88" (98.5 mm)

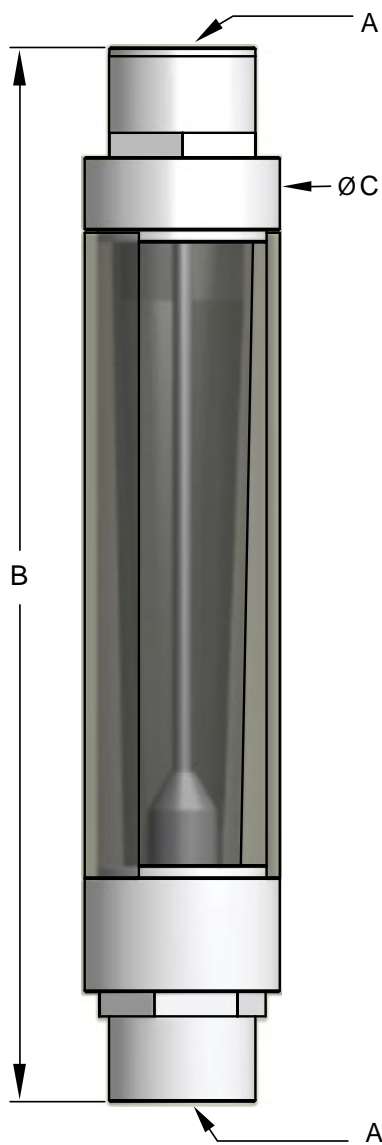

In Line PTFE Flow Meter
No Valve Option

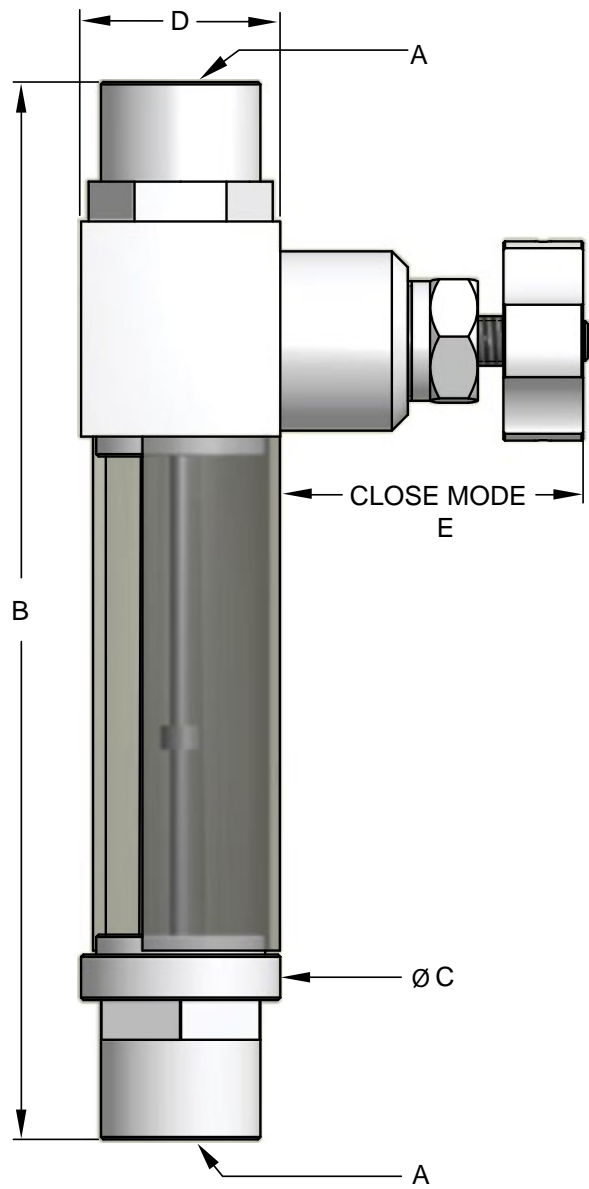

In Line PTFE Flow Meter
Valve Option

NOTE: Aalborg® reserves the right to change designs and dimensions at its sole discretion at any time without notice. For certified dimensions please contact Aalborg®.



Configure and Order Online: [Model F PTFE in-line Flow Meters](#)

F STYLE LOW RANGE METERS				
MODEL NUMBER		CONNECTION	MAXIMUM FLOW	
BUILT IN VALVE	NO VALVE		[mL/min] WATER	[gph] WATER
F6C-F01-01-TF	F3C-F01-01-TF	1/4" FNPT	125	2.0
F6C-F02-01-TF	F3C-F02-01-TF	1/4" FNPT	250	4.0
F6C-F03-01-TF	F3C-F03-01-TF	1/4" FNPT	400	6.5
F6C-F04-01-TF	F3C-F04-01-TF	1/4" FNPT	500	8.0
MODEL NUMBER		CONNECTION	MAXIMUM FLOW	
BUILT IN VALVE	NO VALVE		[Lpm] WATER	[gph] WATER
F6C-F05-01-TF	F3C-F05-01-TF	1/4" FNPT	1.0	16.0
F6D-F06-01-TF	F3D-F06-01-TF	3/8" FNPT	2.0	30.0
F6D-F07-01-TF	F3D-F07-01-TF	3/8" FNPT	2.5	40.0
F6D-F08-01-TF	F3D-F08-01-TF	3/8" FNPT	3.0	50.0
F6D-F09-01-TF	F3D-F09-01-TF	3/8" FNPT	5.0	80.0
F STYLE HIGH RANGE METERS				
MODEL NUMBER		CONNECTION	MAXIMUM FLOW	
BUILT IN VALVE	NO VALVE		[L/min] WATER	[gpm] WATER
F6E-F10-01-TF	F3E-F10-01-TF	1/2" FNPT	13	3.5
F6E-F11-01-TF	F3E-F11-01-TF	1/2" FNPT	20	5.2
F6F-F12-01-TF	F3F-F12-01-TF	3/4" FNPT	30	8.0
F6F-F13-01-TF	F3F-F13-01-TF	3/4" FNPT	40	10.5
F6F-F14-01-TF	F3F-F14-01-TF	3/4" FNPT	45	12.0

L

PTFE-PFA FLOW METERS

Incorporating the principles of traditional rotameter flow technology, these rugged PTFE-PFA flow meters offer solutions to low to medium flow range measurements of highly corrosive or ultra-pure liquids.

Model L meters are constructed of inert materials: PFA, PTFE, and PCTFE. The unique design construction brings about an inert, mechanically rigid flow meter line. Flow meters are also resistant to external, ambient corrosives. For the protection of personnel each flow meter is supplied with a safety shield.

Flow meters are supplied with or without built-in needle valves and they are panel mountable.

design features

- ✓ Constructed from PFA PTFE and PCTFE.
- ✓ Overlapping flow ranges are available for water from 5 mL/min (0.00132 GPM) to 45 L/min (12 GPM).
- ✓ Individually leak tested.

PRINCIPLES OF OPERATION

A cylindrical float freely moving inside a tapered flow tube comprises the flow measurement element of PTFE - PFA flow meters. The translucent PFA flow tube is installed vertically in-line in the liquid stream.

As flow takes place the float is propelled up inside the flow tube. The area between the float and the inside diameter of the flow tube gradually increases with increasing flow and correspondingly the pressure lifting the float decreases until the weight of the float and its buoyant force come to equilibrium. At equilibrium the top of the float is lined up with a scale graduation on the flow tube denoting a discrete rate of flow.

High Range PTFE meter with Valve



Low Range PTFE meter with Valve

LEAK INTEGRITY

Flow meters are individually tested on a Mass Spectrometer Leak Detector and certified to a leak integrity rating of 1×10^{-7} sccs Helium or better.



Configure and Order Online: [Model L PTFE-PFA Flow Meters](#)

ORDERING INFORMATION

L STYLE LOW RANGE METERS

METER SIZE	MODEL NUMBER		CONNECTION	MAXIMUM FLOW	
	BUILT IN VALVE	NO VALVE		[mL/min] WATER	[gph] WATER
C	L6C-L01-01-SA	L3C-L01-01-SA	1/4" FNPT	75	1.20
	L6C-L02-01-TF	L3C-L02-01-TF	1/4" FNPT	250	4.0
	L6C-L03-01-TF	L3C-L03-01-TF	1/4" FNPT	400	6.5
	L6C-L04-01-TF	L3C-L04-01-TF	1/4" FNPT	500	8.0
	L6C-L05-01-TF	L3C-L05-01-TF	1/4" FNPT	1000	16.0

METER SIZE	MODEL NUMBER		CONNECTION	MAXIMUM FLOW	
	BUILT IN VALVE	NO VALVE		[Lpm] WATER	[gph] WATER
D	L6D-L06-01-TF	L3D-L06-01-TF	3/8" FNPT	2.0	31.0
	L6D-L07-01-TF	L3D-L07-01-TF	3/8" FNPT	2.5	40.0
	L6D-L08-01-TF	L3D-L08-01-TF	3/8" FNPT	3.0	47.5
	L6D-L09-01-TF	L3D-L09-01-TF	3/8" FNPT	5.0	80.0

L STYLE HIGH RANGE METERS

METER SIZE	MODEL NUMBER		CONNECTION	MAXIMUM FLOW	
	BUILT IN VALVE	NO VALVE		[L/min] WATER	[gpm] WATER
E	L6E-L10-01-TF	L3E-L10-01-TF	1/2" FNPT	13	3.4
	L6E-L11-01-TF	L3E-L11-01-TF	1/2" FNPT	20	5.25
F	L6F-L12-01-TF	L3F-L12-01-TF	3/4" FNPT	30	8.0
	L6F-L13-01-TF	L3F-L13-01-TF	3/4" FNPT	40	10.5
	L6F-L14-01-TF	L3F-L14-01-TF	3/4" FNPT	45	12.0

SPECIFICATIONS

SCALES	Direct reading scales for liquids with 1.0 specific gravity.
ACCURACY	±5% of full scale.
MAXIMUM TEMPERATURE	250 °F (121 °C).
MAXIMUM PRESSURE	100 psig (6.7 bars).
LEAK INTEGRITY	Individually pressure and leak tested and certified to a rating of 1 x 10 ⁻⁷ sccs of Helium.

**MATERIALS OF CONSTRUCTION

FLOW TUBES	PTFE PFA
FITTINGS	PTFE PFA
FLOATS	PTFE PFA (Sapphire for size 01)
GUIDE RODS	PCTFE

***The selection of materials of construction, is the responsibility of the customer. The company accepts no liability.*

MOUNTING DIMENSIONS

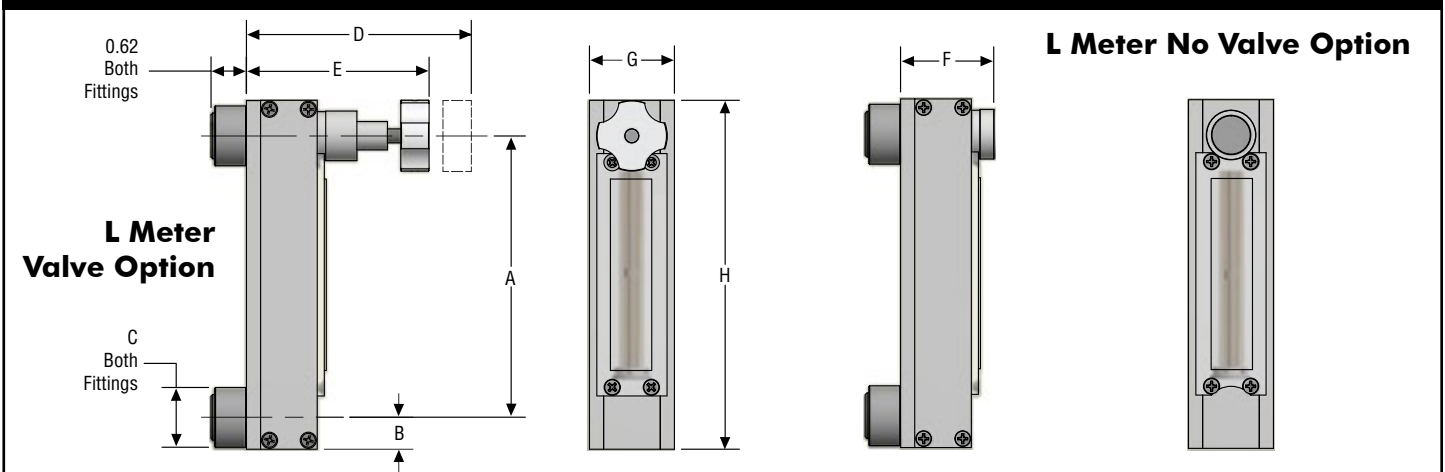

DIMENSIONS FOR L STYLE METERS

METER SIZE	A	B	C	D	E	F	G	H	SCALE LENGTH
C	4.97	0.56	0.812	3.42	3.22	1.65	1.50	6.16	75mm
D	4.97	0.56	1.00	4.72	4.32	1.95	1.75	6.16	75mm
E	8.72	0.88	1.50	4.64	4.14	2.25	2.25	10.47	125mm
F	8.47	1.00	1.50	6.00	5.06	2.80	2.50	10.47	125mm

NOTE: Aalborg® reserves the right to change designs and dimensions at its sole discretion at any time without notice. For certified dimensions please contact Aalborg®.

Designed for controlling very low flow rates of liquids and gases, MFV™ Barstock valves are available in seven conveniently overlapping orifice-needle sizes.



MFV™
Valve-Straight Flow

MFV™
Valve-90 deg Flow

design features

- ✓ Virtually free of hysteresis (see-sawing).
- ✓ Bubble tight shutoff.
- ✓ Straight or 90 degree flow patterns.
- ✓ Brass or 316 stainless steel high resolution.
- ✓ Sixteen turns to full open.

BARSTOCK METERING VALVES MFV™

Offered in straight (T) and 90 degree (L) flow patterns, the MFV™ Barstock Valve includes a “non-rising stem” design, it’s unique non-rotating needle is cylindrical with a precision ground tapered metering surface. The needle moves in a rectilinear fashion which accounts for its desirable sixteen- turn high resolution attribute. Hysteresis is virtually eliminated due to the needle design and the closely fitting fine thread on its adjustment plunger. The valve body is precision machined chrome plated brass or type 316 stainless steel.

SPECIFICATIONS

MAXIMUM PRESSURE	500 psig (3792 kPa).
MAXIMUM TEMPERATURE	180 °F (82 °C) -brass. 250 °F (121 °C).
VALVE STEM	Sixteen turns, non-rising type.

**MATERIALS OF CONSTRUCTION

BODY	Chrome plated brass or 316 stainless steel.
VALVE NEEDLE	316 stainless steel.
ORIFICE	316 stainless steel with PTFE liner for valve sizes 1, 2 and 3; PEEK for valve sizes 4,5,6 and 7.
O-RINGS	Buna® (brass valves). FKM (stainless valves).

***The selection of materials of construction, is the responsibility of the customer. The company accepts no liability.*

Configure and Order Online: [Barstock Metering Valves MFV™](#)

ORDERING INFORMATION BARSTOCK METERING VALVES MFV™						
MODEL NUMBER	FLOW PATTERN	MATERIAL	MAXIMUM FLOW [mL/min]		ORIFICE [in]	CV
			Air	Water		
VM1-BB-1A	Straight	Brass	200	6	0.042	0.0005
VM2-BB-1A	Straight	Brass	400	12	0.042	0.001
VM3-BB-1A	Straight	Brass	1000	30	0.042	0.0025
VM4-BB-1A	Straight	Brass	2500	70	0.093	0.0061
VM5-BB-1A	Straight	Brass	6200	200	0.093	0.016
VM6-BB-1A	Straight	Brass	21500	650	0.093	0.054
VM7-BB-1A	Straight	Brass	46090	1410	0.093	0.118
VM1-SV-2A	Straight	Stainless	200	6	0.042	0.0005
VM2-SV-2A	Straight	Stainless	400	12	0.042	0.001
VM3-SV-2A	Straight	Stainless	1000	30	0.042	0.0025
VM4-SV-2A	Straight	Stainless	2500	70	0.093	0.0061
VM5-SV-2A	Straight	Stainless	6200	200	0.093	0.016
VM6-SV-2A	Straight	Stainless	21500	650	0.093	0.054
VM7-SV-2A	Straight	Stainless	46090	1410	0.093	0.118
VM1-BB-6A	90 degree	Brass	200	6	0.042	0.0005
VM2-BB-6A	90 degree	Brass	400	12	0.042	0.001
VM3-BB-6A	90 degree	Brass	1000	30	0.042	0.0025
VM4-BB-6A	90 degree	Brass	2500	70	0.093	0.0061
VM5-BB-6A	90 degree	Brass	6200	200	0.093	0.016
VM6-BB-6A	90 degree	Brass	21500	650	0.093	0.054
VM7-BB-6A	90 degree	Brass	46090	1410	0.093	0.118
VM1-SV-7A	90 degree	Stainless	200	6	0.042	0.0005
VM2-SV-7A	90 degree	Stainless	400	12	0.042	0.001
VM3-SV-7A	90 degree	Stainless	1000	30	0.042	0.0025
VM4-SV-7A	90 degree	Stainless	2500	70	0.093	0.0061
VM5-SV-7A	90 degree	Stainless	6200	200	0.093	0.016
VM6-SV-7A	90 degree	Stainless	21500	650	0.093	0.054
VM7-SV-7A	90 degree	Stainless	46090	1410	0.093	0.118

Note: Based on 10psig(69 kPa) inlet pressure and atmospheric exhaust.

design features

- ✓ Bubble tight shutoff.
- ✓ Straight or 90 degree flow patterns.
- ✓ Brass or 316 stainless steel.

Designed for controlling a broad range of flow rates of liquids and gases, CV™ Utility valves are available in three conveniently overlapping orifice-needle sizes.

BARSTOCK \ UTILITY VALVES CV™

These versatile, rugged and reliable valves are suitable for laboratory instrumentation, bench top or OEM flow control purposes.

Valves are offered in straight (T) and 90 degree (L) flow patterns. All valves are supplied with 1/8" FNPT inlet and outlet ports.

Valve cartridges are also interchangeable with built-in valves of Aalborg's series of P, T, S, and G flow meter product line.

The valve body is precision machined chrome plated brass or type 316 stainless steel.



**MATERIALS OF CONSTRUCTION

BODY	Chrome plated brass or 316 stainless steel.
VALVE NEEDLE	316 stainless steel.
ORIFICE	KEL-F.
O-RINGS	Buna® (brass valves). FKM (stainless valves).

**The selection of materials of construction, is the responsibility of the customer. The company accepts no liability.

SPECIFICATIONS

MAXIMUM PRESSURE	500 psig (3792 kPa).
MAXIMUM TEMPERATURE	180 °F (82 °C) - (brass valves). 250 °F (121 °C) - (stainless valves).

Configure and Order Online: [Barstock Utility Valves CV™](#)

ORDERING INFORMATION BARSTOCK UTILITY VALVES CV™

MODEL NUMBER	FLOW PATTERN	MATERIAL	MAXIMUM FLOW [mL/min]		ORIFICE [in]	Cv
			Air	Water		
VCL-BB-1A	Straight	Brass	5000	350	0.052	0.03
VCL-SV-2A	Straight	Stainless	5000	350	0.052	0.03
VCL-BB-6A	90 degree	Brass	5000	350	0.052	0.03
VCL-SV-7A	90 degree	Stainless	5000	350	0.052	0.03
VCM-BB-1A	Straight	Brass	20000	1200	0.082	0.10
VCM-SV-2A	Straight	Stainless	20000	1200	0.082	0.10
VCM-BB-6A	90 degree	Brass	20000	1200	0.082	0.10
VCM-SV-7A	90 degree	Stainless	20000	1200	0.082	0.10
VCH-BB-1A	Straight	Brass	60000	3500	0.120	0.30
VCH-SV-2A	Straight	Stainless	60000	3500	0.120	0.30
VCH-BB-6A	90 degree	Brass	60000	3500	0.120	0.30
VCH-SV-7A	90 degree	Stainless	60000	3500	0.120	0.30

Note: Based on 10psig (69 kPa) inlet pressure and atmospheric exhaust.

These compact and reliable PTFE needle valves are designed for laboratory and industrial applications for regulating corrosive gases and liquids or for high purity service. They may also be used as shut off valves.

Pliant PTFE bodies of the valves are reinforced by structurally rigid metallic shells. Fluids contact only PTFE and PEEK materials. Shells are made of anodized aluminum or type 316 stainless steel and bushings are made of plated brass or 316 stainless steel. Where externally corrosive conditions exist stainless steel is recommended.

Valve spindles are made of rigid PEEK to minimize the undesirable material “creeping” normally associated with PTFE. PTFE valves are designed for relatively high flow ranges while still performing well in low flow rates. Valves may be used in pressure or non-critical vacuum service.

The simplicity of design - there are only seven components (including a single PTFE o-ring) - assures reliability and minimizes sources of leakage. It takes seconds to disassemble the valve for cleaning and maintenance. The PTFE o-ring is radially compressed and due to this unique design feature the degree of compression may be adjusted without disassembly by tightening the hexagonal bushing.



PTFE Needle valve with Stainless Shell and FNPT Fittings

SPECIFICATIONS	
MAXIMUM PRESSURE	75 psig (517 kPa)
MAXIMUM TEMPERATURE	150 °F (65 °C)
ORIFICE SIZE	0.125" diameter (3.175 mm)
**MATERIALS OF CONSTRUCTION FLUID CONTACTING	Body and o-ring-PTFE. Valve spindle-PEEK.
NON FLUID CONTACTING	Shell - Aluminum (anodized) or 316 stainless steel. Bushing plated brass, or 316 stainless steel. Adjusting Knob-phenolic.

design features

- ✓ Fluids contact PTFE and PEEK only.
- ✓ Structurally Rigid Metal Shell.
- ✓ One PTFE o-ring.
- ✓ Simplicity only seven components.

Note: Based on 10psig (69 kPa) inlet pressure and atmospheric exhaust.

***The selection of materials of construction, is the responsibility of the customer. The company accepts no liability.*

Configure and Order Online: [PTFE Needle Valves](#)

ORDERING INFORMATION PTFE NEEDLE VALVES						
MODEL NUMBER	MAXIMUM FLOW [ml/min]		CV	NON WETTED MATERIALS		CONNECTIONS
	AIR	WATER		SHELL	BUSHING	
VCL-TT-OA	2400	130	0.011	Aluminum	Brass	1/8" FNPT
VCH-TT-OA	55000	2800	0.250	Aluminum	Brass	1/8" FNPT
VCL-TT-OF	2400	130	0.011	Aluminum	Brass	1/4" Comp.
VCH-TT-OF	55000	2800	0.250	Aluminum	Brass	1/4" Comp.
VCL-TT-OG	2400	130	0.011	Aluminum	Brass	0.390 O.D. Glass Nipples
VCH-TT-OG	55000	2800	0.250	Aluminum	Brass	0.390 O.D. Glass Nipples
VCL-TT-2A	2400	130	0.011	Stainless	Stainless	1/8" FNPT
VCH-TT-2A	55000	2800	0.250	Stainless	Stainless	1/8" FNPT
VCL-TT-2F	2400	130	0.011	Stainless	Stainless	1/4" Comp.
VCH-TT-2F	55000	2800	0.250	Stainless	Stainless	1/4" Comp.
VCL-TT-2G	2400	130	0.011	Stainless	Stainless	0.390 O.D. Glass Nipples
VCH-TT-2G	55000	2800	0.250	Stainless	Stainless	0.390 O.D. Glass Nipples



PTFE Needle valve with Aluminum Shell and Glass Nipples

SPECIFICATIONS

MAXIMUM PRESSURE	75 psig (517 kPa)
MAXIMUM TEMPERATURE	150 °F (65 °C)
ORIFICE SIZE	0.125" diameter (3.175 mm)
NUMBER OF TURNS TO FULLY OPEN	Eight.
STEM	Non-rising type.
FLUID CONTACTING COMPONENTS	Body /o-ring-PTFE. Valve spindle-PEEK.
NON-FLUID CONTACTING COMPONENTS	Shell + Handle - Aluminum (anodized).

* Based on 10 psig (69 kPa) inlet pressure and atmospheric exhaust.

MVT™ Metering valves are constructed of PTFE and PEEK materials.

Non-fluid contacting external parts are made of anodized aluminum. Valves are offered in three conveniently overlapping flow ranges. Safety handle prevents over tightening and facilitates fine metered regulation. MVT™ valves are useful in regulating the flow of corrosive gases and liquids.

They may be used in pressure or non-critical vacuum service and serve as bubble tight shutoff valves.



PTFE Metering Valve

Configure and Order Online: [VT PTFE Metering Valves](#)

ORDERING INFORMATION PTFE METERING VALVE

MODEL NUMBER	MAXIMUM FLOW [ml/min]		Cv	CONNECTIONS
	Air	Water		
VM1-TT-0A	600	36	0.003	1/8" FNPT
VM3-TT-0A	3000	180	0.015	1/8" FNPT
VM6-TT-0A	30000	1800	0.150	1/8" FNPT
VM1-TT-0F	600	36	0.003	1/4" Comp.
VM3-TT-0F	3000	180	0.015	1/4" Comp.
VM6-TT-0F	30000	1800	0.150	1/4" Comp.
VM1-TT-0G	600	36	0.003	0.390 O.D. Glass Nipples
VM3-TT-0G	3000	180	0.015	0.390 O.D. Glass Nipples
VM6-TT-0G	30000	1800	0.150	0.390 O.D. Glass Nipples

design features

- ✓ Fluids contact PTFE and PCTFE only.
- ✓ One PTFE o-ring.
- ✓ Simplicity, only six components.

PTFE needle valves are designed for laboratory and industrial applications for regulating corrosive gases and liquids or for high purity service. They may also be used as shut off valves.

Fluids contact only PTFE and PCTFE materials.

Valve spindles are made of rigid PCTFE to minimize the undesirable material “creeping” normally associated with PTFE.

PTFE valves are designed for relatively high flow ranges while still performing well in low flow rates.

Valves may be used in pressure or non-critical vacuum service.

The simplicity of design - there are only six components (including a single PTFE o-ring) - assures reliability and minimizes sources of leakage. It takes seconds to disassemble the valve for cleaning and maintenance.

The PTFE o-ring is radially compressed and due to this unique design feature the degree of compression may be adjusted without disassembly by tightening the bushing.



6mm PTFE Needle Valves

SPECIFICATIONS

MAXIMUM PRESSURE	75 psig (517 kPa)
MAXIMUM TEMPERATURE	150 °F (65 °C)
ORIFICE SIZE	6.0 mm (0.250") diameter.
**MATERIALS OF CONSTRUCTION FLUID CONTACTING	Body and o-ring-PTFE. Valve spindle-PCTFE.
NON FLUID CONTACTING	Set screws 18-8 stainless steel.

Configure and Order Online: [VT₆ PTFE Needle Valve 6mm Orifice](#)

ORDERING INFORMATION FOR 6mm PTFE NEEDLE VALVES

MODEL NUMBER	MAXIMUM FLOW LPM		Cv	CONNECTIONS
	Air	Water		
VT6-TT-0	300	9	0.765	3/8" FNPT

Note: Based on 10psig (69 kPa) inlet pressure and atmospheric exhaust.



FLOW CAPACITIES Spare valve cartridges P, Px and S meters

TABLE 1 - MFV™ VALVE FLOW CAPACITIES 10 psig (0.7 kPa gauge) INLET PRESSURE, ATMOSPHERIC EXHAUST

SIZE	AIR		HELIUM		WATER	
	[mL/min]	[scfh]	[mL/min]	[scfh]	[mL/min]	[gph]
1	200	0.42	400	0.85	6	0.095
2	400	0.85	850	1.80	12	0.190
3	1020	2.15	2100	4.45	28	0.444
4	2600	5.50	6050	12.80	85	1.347
5	8900	18.85	20800	44.05	270	4.279
6	35000	74.15	84500	179.10	1070	16.960
7	63000	133.50	156000	330.50	1930	30.590



TABLE 2 - CV™ VALVE FLOW CAPACITIES 10 psig (0.7 kPa gauge) INLET PRESSURE, ATMOSPHERIC EXHAUST

SIZE	AIR		HELIUM		WATER	
	[mL/min]	[scfh]	[mL/min]	[scfh]	[mL/min]	[gph]
L	5050	10.70	11500	24.35	360	5.70
M	30000	63.55	71500	151.50	1760	27.90
H	76000	161.05	180000	381.40	4500	71.33



FLOW CAPACITIES Spare valve cartridges T and Tx meters

TABLE 1a - MVT™ VALVE FLOW CAPACITIES 10 psig (0.7 kPa gauge) INLET PRESSURE, ATMOSPHERIC EXHAUST

SIZE	AIR		HELIUM		WATER	
	[mL/min]	[scfh]	[mL/min]	[scfh]	[mL/min]	[gph]
1	600	1.25	1250	2.65	36	0.57
3	3000	6.35	6900	14.60	180	2.85
6	30000	63.55	71500	151.50	1800	28.53



TABLE 2a - CVT™ VALVE FLOW CAPACITIES 10 psig (0.7 kPa gauge) INLET PRESSURE, ATMOSPHERIC EXHAUST

SIZE	AIR		HELIUM		WATER	
	[mL/min]	[scfh]	[mL/min]	[scfh]	[mL/min]	[gph]
L	2400	5.10	5300	11.23	130	2.05
H	55000	116.55	135000	286.05	2800	44.40

METER SIZING FOR P, PX, T, TX AND S METERS

Flow capacity tables 6, 7, 8, 9 and 10 (pages 61 to 64) are based on calibrations at standard conditions, meaning 14.7 psia (1 atm) pressure and 70 °F (21.1 °C).

Tables list maximum flow rates of flow tubes. The usable range of meters is at least 10:1, often more. Thus, as a rule of thumb, to estimate the minimum metering limit divide the flow rates listed, by ten.

For gases or liquids with fluid properties not greatly different from the calibration media, tables apply directly, when working pressure and temperature are also approximately standard.

Where the above conditions do not apply the maximum flow rates of the metered fluids are converted to equivalent standard flow rates of air or water.

To do this calculate “K” as shown in charts, multiply the maximum flow rate with this factor, and select the appropriate flow tube size from the Flow Capacity tables 6, 7, 8, 9 and 10 (pages 61 to 64).

gas flow

$$Q_{air} = K_{gas} \times Q_{gas}$$

$$K_{gas} = \sqrt{G \times \frac{T_{act}}{T_o} \times \frac{P_o}{P_{act}}}$$

where:

- Q_{air} = equivalent air flow capacity at Standard Conditions (SPT).
- Q_{gas} = maximum flow of metered gas.
- G = specific gravity of metered gas (from table 5).
- T_{act} = absolute temperature at flow condition, deg R or deg K.
- T_o = absolute temperature at Standard Conditions. (STP) deg R (530) or deg K (294).
- P_{act} = pressure at flow conditions, psia.
- P_o = pressure at Standard Conditions (STP), (14.7 psia).

liquid flow

$$Q_{water} = K_{liq} \times Q_{liq}$$

$$K_{liq} = \sqrt{\frac{(d_F - d_W)}{(d_F - d_L)} \times \frac{d_L}{d_W}}$$

where:

- Q_{water} = equivalent water flow capacity at Standard Conditions (STP).
- Q_{liq} = maximum flow of metered liquid.
- d_F = density of float selected, (see table 3), (g/ml).
- d_L = density of metered liquid, (g/ml).
- d_W = density of water at Standard Conditions (STP) (1.0 g/ml).

CALCULATION VS. CALIBRATION FOR P, PX, S, T AND TX METERS

In case of liquid flows at each major point along the scale, sample volumes are collected in a buret of a volumetric flask during measured time intervals. Volumes are interpolated to a unit of time such as for example [mL/min] or [cu. ft/hr] etc. A table or a graph is then constructed to establish a complete set of calibration data. In case of gas flows, calibration data can be similarly developed, except that collection of sample volumes is accomplished by means of gas sampling devices, the simplest of which is a “soap bubble” meter.

It is very important that the correction factors as calculated from the accompanying equations are used for sizing only. These relationships are greatly simplified and will not provide precise predictable flow corrections. It is always best practice to calibrate meters for non-standard conditions on site, by using reliable means of calibration.

TECHNICAL INFORMATION

TABLE 3 - FLOAT DENSITIES

MATERIAL	DENSITY [g/ml]
GLASS	2.53
SAPPHIRE	3.98
STAINLESS STEEL	8.04
CARBOLOY	14.98
TANTALUM	16.58

TABLE 4 - CONVERSION FACTORS

MULTIPLY	BY	TO OBTAIN
atm	14.70	lbs/sq. in.
atm	1.0333	kg/sq. cm.
lbs/square inch	0.07031	kg/sq. cm.
ml/min	0.001	liters/min.
ml/min	3.531×10^{-5}	cu. ft./min.
ml/min	1.585×10^{-2}	gal./hr.
cubic ft./hr	472	ml/min.
gal/min	3785	ml/min.
g/ml	62.43	lbs/cu. ft.
g/ml	0.03613	lbs/cu. in.
cc/mn	1	mL/min.
cfm (ft ³ /min)	28.31	L/min.
cfm (ft ³ /min)	1.699	m ³ /hr.
oz/min	29.57	mL/min.

PRESSURE

MULTIPLY	BY	TO OBTAIN
PSI	27.71	in. H ₂ O
PSI	2.036	in. Hg
PSI	703.1	mm/H ₂ O
PSI	51.75	mm/Hg
PSI	.0703	kg/cm ²
PSI	.0689	bar
PSI	68.95	mbar
PSI	6895	Pa
PSI	6.895	kPa

TEMPERATURE

$$^{\circ}\text{F} = (1.8 \times ^{\circ}\text{C}) + 32$$

$$^{\circ}\text{C} = (^{\circ}\text{F} - 32) \times 0.555$$

$$^{\circ}\text{Kelvin} = ^{\circ}\text{C} + 273.2$$

LENGTH

MULTIPLY	BY	TO OBTAIN
Multiply	2.54	cm
Inch	12	inch
Ft.	0.305	meter
Yard	1.094	meter
Angstrom	10^{10}	meter

TABLE 5- DENSITY, VISCOSITY & SPECIFIC GRAVITY OF GASES

GAS	DENSITY [g/ml]	VISCOSITY [centipols]	SPECIFIC GRAVITY G [air=1.0]
Acetylene	0.001090	0.00988	0.9073
Air	0.001200	0.01812	1.0000
Ammonia	0.000716	0.00994	0.5963
Argon	0.001660	0.02220	1.3796
Butane	0.002484	0.00848	2.0854
Carbon Dioxide	0.001835	0.01470	1.5290
Carbon Monoxide	0.001163	0.01750	0.9671
Chlorine	0.002983	0.01330	2.4860
Ethane	0.001260	0.00901	1.0493
Ethylene	0.001170	0.00994	0.9749
Helium	0.0001656	0.01980	0.13804
Hydrogen	0.0000834	0.00885	0.06952
Hydrogen Chloride	0.001512	0.01560	1.2678
Methane	0.0006653	0.01099	0.5544
Nitrogen	0.001160	0.01756	0.96724
Nitrous Oxide	0.001833	0.01453	1.5297
Oxygen	0.001326	0.02030	1.10527
Propane	0.001874	0.00805	1.5620
Sulfur Dioxide	0.002717	0.01270	2.2638

TABLES OF STANDARD FLOW CAPACITIES P, PX, T, TX AND S METERS

TABLE 6
150mm Flow tubes (See Table 8 for Gas Flow Capacities)

FLOW TUBE MAXIMUM FLOW RATES				
FLOW TUBE NUMBER	AIR		WATER	
	[smL/min]	[scfh]	[smL/min]	[gph]
042-29-GL	11.6	0.024	-	-
042-29-SA	18.3	0.038	-	-
042-29-ST	34	0.07	-	-
042-29-CA	62.8	0.13	-	-
042-29-TA	78.9	0.167	-	-
032-41-GL	46.6	0.098	0.50	0.007
032-41-SA	73.1	0.154	0.99	0.015
032-41-ST	138.3	0.293	2.36	0.037
032-41-CA	239.1	0.506	4.60	0.072
032-41-TA	258.7	0.548	5.10	0.080
062-01-GL	91.6	0.194	1.13	0.020
062-01-SA	144.3	0.306	2.19	0.035
062-01-ST	262.2	0.556	4.97	0.079
062-01-CA	431.7	0.915	9.23	0.146
062-01-TA	467.1	0.990	10.15	0.161
112-02-GL	370.6	0.784	5.71	0.090
112-02-SA	513.3	1.087	10.00	0.158
112-02-ST	816.0	1.729	19.2	0.301
112-02-CA	1216.9	2.579	31.6	0.500
112-02-TA	1291.7	2.738	34.1	0.540
082-03-GL	817	1.731	15.2	0.240
082-03-SA	1093	2.316	24.9	0.394
082-03-ST	1665	3.528	44.3	0.702
082-03-CA	2405	5.096	69.0	1.094
082-03-TA	2558	5.420	74.1	1.175
092-04-GL	2214	4.690	49.9	0.792
092-04-SA	2975	6.300	77.7	1.234
092-04-ST	4494	9.520	132.5	2.092
092-04-CA	6467	13.70	203.2	3.218
092-04-TA	6979	14.79	219	3.471
102-05-GL	3780	8.00	89	1.411
102-05-SA	4942	10.47	134	2.124
102-05-ST	7720	16.35	234	3.70
102-05-CA	10780	22.84	343	5.437
102-05-TA	11287	23.92	361	5.722
034-39-GL	8555	18.12	200	3.170
034-39-SA	11140	23.60	301	4.771
034-39-ST	16493	34.94	498	7.893
034-39-CA	23001	48.73	736	11.67
034-39-TA	24540	51.99	784	12.43
044-40-GL	23105	48.95	579	9.177
044-40-SA	29410	62.30	833	13.2
044-40-ST	42860	90.80	1339	21.22
044-40-CA	60212	127.5	1972	31.26
044-40-TA	65625	139.0	2144	33.98

TABLE 7
65mm Flow tubes (See Table 9 for Gas Flow Capacities)

FLOW TUBE MAXIMUM FLOW RATES				
FLOW TUBE NUMBER	AIR		WATER	
	[smL/min]	[scfh]	[smL/min]	[gph]
042-07-GL	5.8	0.013	-	-
042-07-SA	9	0.017	-	-
042-07-ST	19	0.036	-	-
042-07-CA	33	0.070	-	-
042-07-TA	36	0.072	-	-
032-15-GL	49	0.104	0.55	0.009
032-15-SA	74	0.153	0.98	0.016
032-15-ST	145	0.307	2.38	0.038
032-15-CA	246	0.528	4.60	0.073
032-15-TA	271	0.578	5.25	0.084
022-13-GL	107	0.22	1.28	0.020
022-13-SA	167	0.35	2.60	0.041
022-13-ST	314	0.66	6.15	0.098
022-13-CA	517	1.09	11.21	0.179
022-13-TA	563	1.19	12.67	0.202
012-10-GL	216	0.46	3.0	0.048
012-10-SA	320	0.68	5.7	0.091
012-10-ST	538	1.14	11.7	0.187
012-10-CA	826	1.75	20.0	0.320
012-10-TA	898	1.90	22.1	0.353
052-01-GL	1056	2.23	20.8	0.329
052-01-SA	1399	2.96	33.3	0.527
052-01-ST	2125	4.50	58.7	0.930
052-01-CA	3039	6.48	90.0	1.426
052-01-TA	3245	6.87	97.0	1.552
023-92-GL	1249	2.65	25	0.396
023-92-SA	1623	3.44	36.7	0.581
023-92-ST	2520	5.34	70.7	1.121
023-92-CA	3680	7.80	103.5	1.641
013-88-GL	2030	4.3	40.01	0.641
013-88-SA	2655	5.62	63.1	1.0
013-88-ST	4041	8.56	111.2	1.76
013-88-CA	5769	12.22	169.9	2.69
365-02-GL	2522	5.35	54.7	0.86
365-02-ST	4917	10.42	143	2.26
014-96-GL	6318	13.4	147	2.33
014-96-SA	8145	17.3	217	3.44
014-96-ST	12058	25.5	364	5.77
014-96-CA	16943	35.8	540	8.56
014-96-TA	18213	38.6	568	9.00
054-17-GL	12860	27.2	307	4.86
054-17-SA	16617	35.2	449	7.11
054-17-ST	24452	51.8	723	11.46
054-17-CA	34507	73.1	1049	16.63
054-17-TA	36466	77.2	1111	17.61
064-63-GL	21969	46.5	550	8.71
064-63-SA	28518	60.4	811	12.85
064-63-ST	41289	87.4	1297	20.56
064-63-CA	58348	123.6	1895	30.04
064-63-TA	61299	129.9	2000	31.70

*SUFFIX REFERS TO FLOAT MATERIALS;

- GL = Black Glass
- SA = Sapphire (red)
- ST = 316 Stainless Steel
- CA = Carboloy®
- TA = Tantalum

TABLE OF STANDARD FLOW CAPACITIES P, PX, T, TX AND S METERS

TABLE 8 - 150mm FLOW TUBES, GAS FLOW CAPACITIES OF ROUTINE GASES

FLOW TUBE MAXIMUM FLOW RATES												
FLOW TUBE NUMBER	ARGON		CARBON DIOXIDE		HELIUM		HYDROGEN		NITROGEN		OXYGEN	
	[smL/min]	[scfh]	[smL/min]	[scfh]	[smL/min]	[scfh]	[smL/min]	[scfh]	[smL/min]	[scfh]	[smL/min]	[scfh]
032-41-GL	38.1	0.080	55.1	0.116	41.1	0.087	95	0.201	48	0.101	42	0.088
032-41-SA	59.1	0.125	83	0.175	66	0.139	151	0.319	74	0.156	65	0.137
032-41-ST	114	0.241	153	0.324	136	0.288	304	0.644	142	0.300	125	0.264
032-41-CA	197	0.417	255	0.540	254	0.538	553	1.171	246	0.521	217	0.459
032-41-TA	215	0.455	276	0.584	281	0.595	609	1.29	268	0.567	237	0.502
062-01-GL	79.2	0.168	112.8	0.239	94	0.200	211	0.447	93	0.197	87	0.185
062-01-SA	119	0.253	156	0.331	149	0.316	327	0.693	148	0.314	131	0.278
062-01-ST	217	0.460	272	0.577	288	0.611	632	1.339	269	0.570	239	0.507
062-01-CA	368	0.780	431	0.914	518	1.098	1100	2.331	443	0.939	396	0.839
062-01-TA	388.3	0.823	464.1	0.983	571.9	1.212	1200.3	2.543	478.8	1.015	429	0.909
112-02-GL	307	0.650	358.3	0.758	453	0.959	981	2.079	378	0.800	340	0.012
112-02-SA	429	0.909	485	1.028	708	1.500	1420	3.009	525	1.112	478	1.013
112-02-ST	682	1.445	740	1.568	1352	2.865	2366	5.013	832	1.763	756	1.621
112-02-CA	1022	2.165	1080	2.288	2228	4.721	3688	7.814	1243	2.634	1141	2.418
112-02-TA	1090	2.310	1140.9	2.418	2404.6	5.096	4257	9.020	1321.4	2.799	1211	2.566
082-03-GL	685	1.451	705	1.494	1488	3.153	2459	5.210	834	1.767	761	1.612
082-03-SA	919	1.947	950	2.013	2105	4.460	3546	7.514	1117	2.367	1022	2.165
082-03-ST	1403	2.973	1362	2.886	3443	7.295	5359	11.36	1699	3.600	1573	3.333
082-03-CA	2029	4.299	2076	4.399	5197	11.01	7967	16.88	2452	5.195	2275	4.820
082-03-TA	2159	4.575	2182	4.623	5530	11.72	8511	18.03	2608	5.526	2406	5.098
092-04-GL	1896	4.01	1976	4.18	4727	10.02	7557	16.01	2288	4.84	2113	4.47
092-04-SA	2516	5.33	2610	5.53	6310	13.37	10202	21.62	3032	6.42	2806	5.94
092-04-ST	3805	8.06	3887	8.23	9728	20.61	15754	33.38	4578	9.70	4247	8.99
092-04-CA	5525	11.71	5599	11.86	14158	30.00	23232	49.23	6640	14.07	6170	13.07
092-04-TA	5914	12.53	5954	12.62	15227	32.26	24927	52.82	7103	15.05	6604	13.99
102-05-GL	3148	6.67	3266	6.92	8526	18.07	13164	27.89	3824	8.10	3549	7.52
102-05-SA	4185	8.86	4314	9.14	10384	22.00	17434	36.94	5033	10.66	4672	9.89
102-05-ST	6329	13.41	6288	13.32	15906	33.70	26770	56.72	7603	16.11	7069	14.98
102-05-CA	9082	19.24	8976	19.02	23416	49.62	39080	82.81	10974	23.25	10185	21.58
102-05-TA	9573	20.28	9351	19.81	24794	52.54	40968	86.81	11490	24.35	10697	22.67
034-39-GL	7266	15.39	7304	15.47	19040	40.33	29795	63.12	8695	18.42	8091	17.14
034-39-SA	9373	19.85	9406	19.92	24810	52.56	39101	82.84	11270	23.87	10535	22.31
034-39-ST	13977	29.61	13728	29.08	39280	83.22	58968	124.9	16794	35.58	15610	33.07
034-39-CA	19580	41.48	19296	40.88	54965	116.4	84023	178.0	23444	49.66	22000	46.61
034-39-TA	20938	44.36	20543	43.52	60207	127.5	89109	188.7	25084	53.14	23500	49.78
044-40-GL	19472	41.25	19220	40.72	53552	113.4	83730	177.3	23432	49.64	21832	46.25
044-40-SA	24878	52.70	24263	51.40	71100	150.6	106992	226.6	29798	63.13	27937	59.26
044-40-ST	36564	77.46	35541	75.29	106151	224.8	157719	334.1	43607	92.38	41076	87.02
044-40-CA	51689	109.5	50243	106.4	161232	341.5	224353	475.3	61653	130.6	57480	121.7
044-40-TA	55248	117.0	53771	113.9	171090	362.4	243016	514.8	66954	141.8	61892	131.1

*Suffix refers to float materials: G = black glass, S = sapphire (red), ST = 316 stainless steel, C = Carboloy®, T = tantalum.

Flow capacities shown in Tables 4, 5, 6 and 7 are based on calibrations at standard (STP) conditions (70 °F / 21.1 °C and 14.7psia/1 atm abs). For fluids other than air or water at STP conditions see paragraph on METER SIZING on page 59. For special OEM requirements call toll free 1-800-866-3837.

for direct reading (engineering units) scale flow tubes contact the company or visit us at www.aalborg.com

TABLE OF STANDARD FLOW CAPACITIES P, PX, T, TX AND S METERS

TABLE 9 - 65mm FLOW TUBES, GAS FLOW CAPACITIES OF ROUTINE GASES

FLOW TUBE MAXIMUM FLOW RATES												
FLOW TUBE NUMBER	ARGON		CARBON DIOXIDE		HELIUM		HYDROGEN		NITROGEN		OXYGEN	
	[smL/min]	[scfh]	[smL/min]	[scfh]	[smL/min]	[scfh]	[smL/min]	[scfh]	[smL/min]	[scfh]	[smL/min]	[scfh]
042-07-GL	4	0.01	6.5	0.01	5.5	0.01	9.6	0.02	5.6	0.01	5	0.01
042-07-SA	7.7	0.02	10	0.02	8	0.02	15.3	0.03	8.5	0.02	7	0.01
042-07-ST	14	0.03	20	0.04	16	0.03	32.3	0.07	18	0.04	15	0.03
042-07-CA	28	0.06	39	0.08	30	0.06	53.6	0.11	34	0.07	29	0.06
042-07-TA	29	0.06	40	0.08	32	0.07	64.8	0.14	34	0.07	30	0.06
032-15-GL	38	0.08	59	0.13	47	0.10	100	0.21	51	0.11	46	0.10
032-15-SA	63	0.13	90	0.19	71	0.15	150	0.32	78	0.17	72	0.15
032-15-ST	122	0.26	160	0.34	146	0.31	314	0.67	149	0.32	132	0.28
032-15-CA	214	0.45	263	0.56	274	0.58	593	1.26	264	0.56	239	0.51
032-15-TA	224	0.47	279	0.59	294	0.62	654	1.39	276	0.58	248	0.53
022-13-GL	86	0.19	121	0.26	103	0.22	230	0.49	107	0.23	94	0.20
022-13-SA	132	0.28	176	0.38	164	0.35	367	0.78	164	0.35	145	0.31
022-13-ST	246	0.53	307	0.65	312	0.67	728	1.55	304	0.65	271	0.58
022-13-CA	403	0.86	478	1.02	562	1.19	1257	2.67	496	1.05	445	0.95
022-13-TA	435.2	0.93	513.4	1.09	616.5	1.31	1370	2.91	535.7	1.14	481.1	1.02
012-10-GL	169	0.35	218	0.46	207	0.43	496	1.05	210	0.44	187	0.39
012-10-SA	251	0.53	305	0.64	331	0.70	768	1.62	310	0.65	277	0.58
012-10-ST	432	0.91	501	1.06	665	1.40	1399	2.96	531	1.12	478	1.01
012-10-CA	677	1.43	729	1.54	1194	2.52	2298	4.86	828	1.75	751	1.59
012-10-TA	712	1.50	771	1.63	1273	2.69	2426	5.13	870	1.84	789	1.67
052-01-GL	886	1.87	939	1.98	2070	4.38	3294	6.98	1086	2.30	1003	2.12
052-01-SA	1185	2.51	1227	2.59	2852	6.04	4477	9.49	1419	3.00	1344	2.84
052-01-ST	1794	3.80	1838	3.89	4573	9.68	7061	14.96	2164	4.58	2022	4.28
052-01-CA	2573	5.45	2629	5.56	6762	14.32	10394	21.93	3105	6.57	2912	6.16
052-01-TA	2742	5.80	2774	5.87	7190	15.23	11056	23.43	3293	6.97	3094	6.55
023-92-GL	1030	2.19	1114	2.36	1934	4.10	3590	7.61	1251	2.65	1150	2.44
023-92-SA	1399	2.97	1494	3.17	2878	6.10	5022	10.64	1702	3.61	1568	3.33
023-92-ST	2141	4.54	2224	4.72	4886	10.36	8251	17.48	2576	5.46	2381	5.05
023-92-CA	3103	6.58	3194	6.77	7580	16.06	12517	26.52	3767	7.98	3480	7.38
013-88-GL	1687	3.57	1787	3.78	3344	7.08	6255	13.25	2048	4.33	1876	3.97
013-88-SA	2240	4.74	2338	4.95	4966	10.52	8506	18.02	2737	5.79	2493	5.28
013-88-ST	3426	7.25	3508	7.43	8258	17.49	13435	28.46	4112	8.71	3817	8.08
013-88-CA	4928	10.44	4957	10.50	12672	26.84	19783	41.91	5943	12.59	5494	11.63
365-02-GL	2106	4.47	2188	4.64	4748	10.06	7770	16.47	2563	5.43	2373	5.03
365-02-ST	4141	8.78	4106	8.70	10903	23.10	16980	35.98	5034	10.67	4657	9.87
014-96-GL	5290	11.21	5379	11.4	13639	28.9	21327	45.2	6380	13.52	5880	124.5
014-96-SA	6900	14.62	6980	14.79	18500	39.19	28211	59.77	8280	17.54	7690	16.29
014-96-ST	10175	21.56	10150	21.50	27300	57.84	41889	88.76	12058	25.55	11250	23.83
014-96-CA	14293	30.28	14200	30.08	40036	84.84	58498	123.9	17253	36.55	16031	33.97
014-96-TA	15168	32.14	15088	36.55	42396	89.84	63885	135.4	18250	38.67	16939	35.89
054-17-GL	10895	23.09	10811	22.91	29355	62.20	47100	99.8	13096	27.75	12166	25.78
054-17-SA	14085	29.85	14000	29.67	38325	81.20	61715	130.7	16919	35.85	15733	33.34
054-17-ST	20740	43.94	20307	43.03	57120	121.0	90323	191.3	24891	52.74	23174	49.10
054-17-CA	29280	62.04	28420	60.22	81800	173.3	130805	277.1	35122	74.42	32724	69.33
054-17-TA	30944	65.56	30570	64.77	87573	185.5	139224	294.9	37115	78.64	34585	73.28
064-63-GL	18625	39.46	18159	38.48	50441	106.87	79680	168.82	22501	47.68	20812	44.10
064-63-SA	24193	51.26	23513	49.82	66312	140.50	104110	220.58	29027	61.50	27038	57.29
064-63-ST	35263	74.71	34151	72.36	104993	222.45	152772	323.67	41985	88.96	39416	83.51
064-63-CA	49534	104.95	47860	101.40	143606	304.25	215595	456.77	59377	125.80	55375	117.32
064-63-TA	52041	110.26	50268	106.50	156768	332.14	226636	480.17	62380	132.17	57772	122.40

TECHNICAL INFORMATION

TABLE OF FLOW CAPACITIES AT 50 PSIG FOR GAS PROPORTIONERS

TABLE 10 - 150mm FLOW TUBES, GAS FLOW CAPACITIES FOR GAS PROPORTIONERS at 50 PSIG

FLOW TUBE MAXIMUM FLOW RATES							
FLOW TUBE NUMBER	AIR [smL/min]	ARGON [smL/min]	CARBON DIOXIDE [smL/min]	HELIUM [smL/min]	HYDROGEN [smL/min]	NITROGEN [smL/min]	OXYGEN [smL/min]
032-41-GL	191	161	203	195	399	197	166
032-41-SA	270	229	279	302	662	283	246
032-41-ST	460	383	478	573	1185	471	442
032-41-CA	743	625	702	1094	2013	771	719
062-01-GL	324	270	346	333	844	331	294
062-01-SA	505	412	494	569	1209	467	460
062-01-ST	825	687	771	1089	2432	833	764
062-01-CA	1275	1062	1132	1972	3732	1303	1175
112-02-GL	1086	855	934	1779	3110	1016	930
112-02-SA	1324	1115	1168	2468	4289	1340	1228
112-02-ST	2024	1717	1724	4083	6740	2034	1905
112-02-CA	2912	2472	2521	6927	9979	2997	2703
082-03-GL	2008	1697	1747	4214	6711	2039	1865
082-03-SA	2590	2186	2264	5656	8995	2643	2503
082-03-ST	3903	3274	3343	8669	14490	3731	3685
082-03-CA	5547	4697	4691	12717	19993	6169	5210
092-04-GL	5528	4794	4954	12540	18862	5801	5381
092-04-SA	7240	6163	6217	15703	25235	7415	6826
092-04-ST	10813	9077	9178	24629	38556	11044	10335
092-04-CA	15322	12904	12879	34709	55936	15433	14451
102-05-GL	9294	7705	7888	19830	30900	9419	8749
102-05-SA	11647	9969	10042	26008	45263	11955	11137
102-05-ST	17311	14489	14420	40831	60300	17525	16353
102-05-CA	24065	20744	20099	59702	86369	24549	22905
034-39-GL	19767	17978	17936	48193	73500	21676	19931
034-39-SA	27514	23001	54010	63240	97000	27449	25800
034-39-ST	38995	33778	33087	98676	142000	40086	36821
034-39-CA	55293	47151	45745	139847	200500	55930	52494
044-40-GL	49374	41899	40520	125617	182239	50258	46851
044-40-SA	62480	53038	51220	159976	231239	63595	59304
044-40-ST	89880	76322	73584	231946	333775	91478	85341
044-40-CA	123846	105182	101303	321265	460942	126041	117615

DIRECT READING SCALES FOR P, PX, T, TX AND S METERS

TABLE 11 - FLOW TUBES FOR AIR

65mm				150mm			
FLOW TUBE	QMAX	[UNITS]	PRESSURE	FLOW TUBE	QMAX	[UNITS]	PRESSURE
042-10-GL	7.00	mL/min	14.70 psia	042-12-SA	25.00	mL/min	14.70 psia
032-01-ST	50.00	mL/min	14.70 psia	032-06-SA	52.00	mL/min	14.70 psia
062-04-ST	75.00	mL/min	14.70 psia	042-06-CA	75.00	mL/min	14.70 psia
022-14-GL	100.00	mL/min	14.70 psia	032-10-ST	100.00	mL/min	14.70 psia
032-03-CA	250.00	mL/min	14.70 psia	032-21-ST	150.00	mL/min	14.70 psia
022-05-CA	500.00	mL/min	14.70 psia	062-03-ST	200.00	mL/min	14.70 psia
052-12-GL	1000.00	mL/min	14.70 psia	112-10-GL	300.00	mL/min	14.70 psia
052-04-GL	1.00	L/min	14.70 psia	112-08-SA	500.00	mL/min	14.70 psia
023-03-GL	1.15	L/min	14.70 psia	082-02-GL	800.00	mL/min	14.70 psia
052-07-ST	2.00	L/min	14.70 psia	112-19-CA	1.25	L/min	14.70 psia
013-89-ST	4.00	L/min	14.70 psia	082-12-ST	1.80	L/min	14.70 psia
014-03-GL	5.00	L/min	14.70 psia	092-25-GL	2.50	L/min	14.70 psia
014-02-ST	10.00	L/min	14.70 psia	102-07-GL	4.00	L/min	14.70 psia
044-11-ST	16.00	L/min	14.70 psia	102-03-SA	4.50	L/min	14.70 psia
054-01-ST	25.00	L/min	14.70 psia	092-14-ST	4.80	L/min	14.70 psia
064-03-ST	40.00	L/min	14.70 psia	102-01-SA	5.00	L/min	14.70 psia
052-05-GL	2.20	scfh	14.70 psia	102-16-CA	10.00	L/min	14.70 psia
365-18-GL	6.00	scfh	14.70 psia	034-13-ST	17.00	L/min	14.70 psia
365-19-ST	10.00	scfh	14.70 psia	044-14-GL	23.00	L/min	14.70 psia
034-61-ST	18.00	scfh	14.70 psia	044-41-ST	42.00	L/min	14.70 psia
014-17-ST	25.00	scfh	14.70 psia	044-16-CA	60.00	L/min	14.70 psia
054-02-ST	50.00	scfh	14.70 psia	112-01-CA	2.50	scfh	14.70 psia
064-62-ST	90.00	scfh	14.70 psia	092-09-GL	5.00	scfh	14.70 psia
074-02-CA	150.00	scfh	14.70 psia	102-06-GL	8.25	scfh	14.70 psia
014-01-CA	0.60	scfm	14.70 psia	092-10-ST	10.00	scfh	14.70 psia
				102-08-ST	16.50	scfh	14.70 psia
				102-09-CA	23.00	scfh	14.70 psia
				044-05-GL	55.00	scfh	14.70 psia
				044-18-ST	90.00	scfh	14.70 psia
				044-07-ST	94.00	scfh	14.70 psia
				044-23-SA	1.00	scfm	14.70 psia
				044-43-ST	1.50	scfm	14.70 psia

TABLE 12 - FLOW TUBES FOR WATER

65mm				150mm			
FLOW TUBE	QMAX	[UNITS]	PRESSURE	FLOW TUBE	QMAX	[UNITS]	PRESSURE
032-04-GL	0.50	mL/min	14.70 psia	032-05-SA	1.00	mL/min	14.70 psia
022-08-ST	6.00	mL/min	14.70 psia	112-12-SA	10.00	mL/min	14.70 psia
052-09-GL	25.00	mL/min	14.70 psia	112-05-ST	20.00	mL/min	14.70 psia
052-08-ST	60.00	mL/min	14.70 psia	092-02-GL	50.00	mL/min	14.70 psia
013-02-ST	115.00	mL/min	14.70 psia	092-08-GL	60.00	mL/min	14.70 psia
365-01-ST	150.00	mL/min	14.70 psia	102-11-GL	100.00	mL/min	14.70 psia
044-09-GL	250.00	mL/min	14.70 psia	092-06-CA	200.00	mL/min	14.70 psia
064-05-GL	500.00	mL/min	14.70 psia	044-15-ST	1.20	L/min	14.70 psia
054-03-ST	750.00	mL/min	14.70 psia	044-01-TA	2.00	L/min	14.70 psia
064-04-SA	1.00	L/min	14.70 psia	044-12-SA	0.22	gpm	14.70 psia
064-06-ST	1.20	L/min	14.70 psia	044-42-CA	0.45	gpm	14.70 psia
052-16-ST	3.00	L/hr	14.70 psia	044-10-CA	29.00	gph	14.70 psia
034-74-ST	2.7	gph	14.70 psia				
064-12-GL	10.00	gph	14.70 psia				
064-09-CA	24.00	gph	14.70 psia				
064-11-TA	32.00	gph	14.70 psia				

TECHNICAL INFORMATION

DIRECT READING SCALES FOR P, PX, T, TX AND S METERS

TABLE 13 - FLOW TUBES FOR ARGON

65mm				150mm			
FLOW TUBE	QMAX	[UNITS]	PRESSURE	FLOW TUBE	QMAX	[UNITS]	PRESSURE
052-15-SA	1000.00	mL/min	14.70 psia	062-10-CA	325.00	mL/min	14.70 psia
013-09-CA	4.5	L/min	14.70 psia	032-18-GL	33.00	mL/min	14.70 psia
064-14-SA	26.00	L/min	14.70 psia	082-11-CA	2.00	L/min	14.70 psia
023-05-GL	2.50	scfh	14.70 psia	034-07-ST	15.00	L/min	14.70 psia
365-17-ST	10.00	scfh	14.70 psia	044-22-SA	25.00	L/min	14.70 psia
014-14-ST	22.00	scfh	14.70 psia				
064-01-GL	50.00	scfh	14.70 psia				

TABLE 14 - FLOW TUBES FOR CARBON DIOXIDE

65mm				150mm			
FLOW TUBE	QMAX	[UNITS]	PRESSURE	FLOW TUBE	QMAX	[UNITS]	PRESSURE
042-20-SA	10.00	mL/min	14.70 psia	062-09-GL	100.00	mL/min	14.70 psia
042-09-ST	20.00	mL/min	14.70 psia	032-32-ST	150.00	mL/min	14.70 psia
032-20-GL	55.00	mL/min	14.70 psia	062-14-ST	300.00	mL/min	14.70 psia
022-24-SA	220.00	mL/min	14.70 psia	092-18-SA	2.5	L/min	14.70 psia
052-14-GL	1.00	L/min	14.70 psia	034-18-SA	10.00	L/min	14.70 psia
023-07-ST	2.00	L/min	14.70 psia				
014-18-GL	6.00	L/min	14.70 psia				
014-19-ST	10.00	L/min	14.70 psia				
064-08-ST	35.00	L/min	14.70 psia				

TABLE 15 - DIRECT READING FLOW TUBES FOR FUEL OIL

150mm			
FLOW TUBE	QMAX	[UNITS]	PRESSURE
034-60-GL	3.00	gph	14.70 psia

TABLE 16 - DIRECT READING FLOW TUBES FOR HELIUM

65mm				150mm			
FLOW TUBE	QMAX	[UNITS]	PRESSURE	FLOW TUBE	QMAX	[UNITS]	PRESSURE
032-07-SA	65.00	mL/min	14.70 psia	062-13-GL	100.00	mL/min	14.70 psia
022-02-GL	120.00	mL/min	14.70 psia	062-07-CA	500.00	mL/min	14.70 psia
014-04-GL	30.00	scfh	14.70 psia	082-05-GL	1500.00	mL/min	14.70 psia
				082-07-CA	5.00	L/min	14.70 psia
				034-09-ST	40.00	L/min	14.70 psia
				112-03-SA	1.25	scfh	14.70 psia

TABLE 17 - DIRECT READING FLOW TUBES FOR HYDROGEN

65mm				150mm			
FLOW TUBE	QMAX	[UNITS]	PRESSURE	FLOW TUBE	QMAX	[UNITS]	PRESSURE
032-13-GL	35.00	mL/min	14.70 psia	032-12-GL	100.00	mL/min	14.70 psia
042-01-CA	100.00	mL/min	14.70 psia	092-15-SA	20.00	scfh	14.70 psia
032-02-SA	150.00	mL/min	14.70 psia	044-20-SA	225.00	scfh	14.70 psia
012-01-GL	600.00	mL/min	14.70 psia				
022-01-CA	1.50	L/min	14.70 psia				
023-01-GL	3.50	L/min	14.70 psia				
013-01-GL	6.00	L/min	14.70 psia				
014-15-ST	42.00	L/min	14.70 psia				
013-08-ST	30.00	scfh	14.70 psia				

DIRECT READING SCALES FOR P, PX, T, TX AND S METERS

TABLE 18- DIRECT READING FLOW TUBES FOR METHANE

65mm			
FLOW TUBE	QMAX	[UNITS]	PRESSURE
042-03-ST	40.00	mL/min	14.70 psia

TABLE 19- DIRECT READING FLOW TUBES FOR NITROUS OXIDE

150mm			
FLOW TUBE	QMAX	[UNITS]	PRESSURE
112-11-SA	500.00	mL/min	14.70 psia

TABLE 20 - DIRECT READING FLOW TUBES FOR NITROGEN

65mm				150mm			
FLOW TUBE	QMAX	[UNITS]	PRESSURE	FLOW TUBE	QMAX	[UNITS]	PRESSURE
042-08-GL	6.00	mL/min	14.70 psia	062-12-GL	100.00	mL/min	14.70 psia
032-16-ST	50.00	mL/min	14.70 psia	032-22-CA	200.00	mL/min	14.70 psia
032-08-SA	60.00	mL/min	14.70 psia	062-30-CA	300.00	mL/min	14.70 psia
022-15-GL	120.00	mL/min	14.70 psia	112-06-SA	500.00	mL/min	14.70 psia
022-06-SA	200.00	mL/min	14.70 psia	032-31-GL	50.00	mL/min	14.70 psia
014-16-ST	12.00	L/min	14.70 psia	092-05-GL	2.00	L/min	14.70 psia
064-13-GL	20.00	L/min	14.70 psia	102-21-ST	7.00	L/min	14.70 psia
				034-24-ST	14.00	L/min	14.70 psia
				044-25-CA	50.00	L/min	14.70 psia
				044-24-TA	66.00	L/min	14.70 psia
				044-06-ST	1.60	scfm	14.70 psia

TABLE 21 - DIRECT READING FLOW TUBES FOR OXYGEN

65mm				150mm			
FLOW TUBE	QMAX	[UNITS]	PRESSURE	FLOW TUBE	QMAX	[UNITS]	PRESSURE
042-21-ST	10.00	mL/min	14.70 psia	032-33-ST	150.00	mL/min	14.70 psia
032-09-GL	35.00	mL/min	14.70 psia	062-02-ST	250.00	mL/min	14.70 psia
032-19-GL	50.00	mL/min	14.70 psia	112-04-SA	400.00	mL/min	14.70 psia
022-07-ST	300.00	mL/min	14.70 psia	062-16-CA	600.00	mL/min	14.70 psia
012-02-ST	500.00	mL/min	14.70 psia	082-08-SA	1.00	L/min	14.70 psia
052-02-GL	1.00	L/min	14.70 psia	102-12-SA	5.00	L/min	14.70 psia
013-25-ST	4.00	L/min	14.70 psia	102-17-CA	10.00	L/min	14.70 psia
034-08-ST	8.00	L/min	14.70 psia	034-15-ST	16.50	L/min	14.70 psia
044-04-ST	15.00	L/min	14.70 psia	044-19-CA	58.00	L/min	14.70 psia

TABLE 22 - DIRECT READING FLOW TUBES FOR PROPANE

150mm			
FLOW TUBE	QMAX	[UNITS]	PRESSURE
092-01-ST	4.20	L/min	14.70 psia
102-02-CA	10.00	L/min	14.70 psia
044-02-ST	38.00	L/min	14.70 psia

COMMON EQUIVALENTS AND CONVERSIONS

Approximate Common Equivalents	
1 inch	= 25 millimeter
1 foot	= 0.3 meter
1 yard	= 0.9 meter
1 mile	= 1.6 kilometers
1 square inch	= 6.5 sq centimeters
1 square foot	= 0.09 square meter
1 square yard	= 0.8 square meter
1 acre	= 0.4 hectare +
1 cubic inch	= 16 cu centimeters
1 cubic foot	= 0.03 cubic meter
1 cubic yard	= 0.8 cubic meter
1 quart (lq)	= 1 liter +
1 gallon	= 0.004 cubic meter
1 ounce (avdp)	= 28 grams
1 pound (avdp)	= 0.45 kilogram
1 horsepower	= 0.75 kilowatt
1 millimeter	= 0.04 inch
1 meter	= 3.3 feet
1 meter	= 1.1 yards
1 kilometer	= 0.6 mile
1 square centimeter	= 0.16 square inch
1 square meter	= 11 square feet
1 square meter	= 1.2 square yards
1 hectare +	= 2.5 acres
1 cubic centimeter	= 0.06 cubic feet
1 cubic meter	= 35 cubic feet
1 cubic meter	= 1.3 cubic yards
1 liter +	= 1 quart
1 cubic meter	= 250 gallons
1 gram	= 0.035 ounces (avdp)
1 kilogram	= 2.2 pounds (avdp)
1 kilowatt	= 1.3 horsepower

Conversions Accurate to Parts Per Million	
inches X 25.4*	= millimeters
feet X 0.3048*	= meters
yards X 0.9144*	= meters
miles X 1.603 34	= kilometers
square inches X 6.4516*	= square centimeters
square feet X 0.92 903 0	= square meters
square yards X 0.836 127	= square meters
acres X 0.404 686	= hectares
cubic inches X 16.3871	= cubic centimeters
cubic feet X 0.028 316.8	= cubic meters
cubic yards X 0.764 555	= cubic meters
quarts (lq) X 0.946 353	= liters
gallons X 0.003 785 41	= cubic meters
ounces (avdp) X 28.3495	= grams
pounds (avdp) X 0.453 592	= kilograms
horsepower X 0.745 700	= kilowatts
millimeters X 0.039 370 1	= inchs
meters X 3.280 84	= feet
meters X 1.093 61	= yards
kilometers X 0.621 371	= miles
sq centimeters X 0.155 000	= square inchs
square meters X 10.7639	= square feet
square meters X 1.195 99	= square yards
hectares X 2.471 05	= acres
cu centimeters X 0.061 623 7	= cubic inches
cubic meters X 35.3147	= cubic feet
cubic meters X 1.307 95	= cubic yards
liters X 1.056 69	= quarts (lq)
cubic meters X 264.172	= gallons
grams 0.035 274 0	= ounces (avdp)
kilograms X 2.204 62	= pounds (avdp)
kilowatts 1.341 02	= horsepower

THESE PREFIXES MAY BE APPLIED TO ALL SI UNITS	
Multiples and Submultiples	
1 000 000 000 000	= 10 ¹²
1 000 000 000	= 10 ⁹
1 000 000	= 10 ⁶
1000	= 10 ³
100	= 10 ²
10	= 10
0.1	= 10 ⁻¹
0.01	= 10 ⁻²
0.001	= 10 ⁻³
0.000 001	= 10 ⁻⁶
0.000 000 001	= 10 ⁻⁹
0.000 000 000 001	= 10 ⁻¹²
0.000 000 000 000 001	= 10 ⁻¹⁵
0.000 000 000 000 000 001	= 10 ⁻¹⁸

Prefixes	Symbols
tara (ter'a)	T
giga (ji ga)	G
mega (meg'a)	Ma
kilo (kil o)	k*
hecto (hek'to)	h
deka (dek'a)	da
deci (des'i)	d
centi (sen'ti)	c*
milli (mil'i)	m*
micro (mi' kro)	u*
nano (nan'o)	n
pico (pe'ko)	p
femto (fem'to)	f
atto (at'to)	a

+ common term not used in SI
* exact

Source: NBS Special Pub. 304.

EUROPEAN SERVICE CENTER

Authorized Repair and Service Facility for Aalborg Thermal
Mass Flow Systems Aalborg-MESSTECHNIK GMBH Klosterrensstraße
18 P.O. Box 1321 Müllheim D-79379 Germany
Telefon: +49 (0)7631 5545 / Fax: +49 (0)7631 14740
Website: www.analyt-mtc.de / e-mail: info@analyt-mtc.de

175, avenue d'Alsace 68000 COLMAR
Tel: 03 89 41 47 78 / Fax: 03 89 41 59 88
e-mail: ANALYT_MTC@T-online.de

ASIAN SERVICE FACILITY

Authorized Repair and Service Facility for Aalborg Thermal
Mass Flow Systems aalborg- Beijing Comity Measure & Control Co.

Floor 1 Tower B Jindayuan Office Building
Xisangqi, Hai Dian District, Beijing, China
Phone: 86-10-6295-0464, 86-10-6295-0465
Fax: 86-10-6295-0466
Website: <http://www.comity-tec.com>

Products Manufactured By Aalborg

ROTAMETERS

Single Tube

Aluminum / Brass / Stainless ● Interchangeable Glass Flow Tubes ● Optional Valves

Multiple Tube

Two to Six Channels ● Aluminum or Stainless

PTFE Single and Multiple Tube

Chemically Inert ● 1 to 4 Channels ● Interchangeable Glass Flow tubes

PTFE - PFA

Chemically Inert ● Low to Medium Flow of Corrosive Liquids with PFA Flow Tube

Kits

Aluminum / Stainless / PTFE ● Including Five Glass Flow Tubes and a Set of Floats

Gas Proportioners

Aluminum / Stainless ● Used for Blending Two or Three Gases

Medium Range

Glass Safety Shield ● Dual Air and Water Scale

Optical Sensor Switch

Non-Invasive Means for Detection of a High or Low Flow

High Flow Industrial Stainless Steel Flow Meters

Heavy Duty Stainless Steel ● Direct Reading Air and Water Scales

ELECTRONIC METERS & CONTROLLERS

Low Cost Mass Flow Meters

Aluminum or Stainless ● With or Without LCD Readout

Low Cost Mass Flow Controllers

Aluminum or Stainless ● With or Without LCD Readout

Mass Flow Controllers

Stainless ● One to Four Channel Systems

Digital Mass Flow Controllers

Auto Zero ● Totalizer ● Alarms = Built in RS485

Multi Parameter Digital Mass Flow Meters

Displays Flow Pressure and Temperature

Paddle Wheel Meters

For Liquids ● Optional Temperature Measurements

Vortex In-Line and Insertion Flow Meters

Steam / Liquid and Gas Service

Smart Rate / Totalizer / Signal Conditioner

LCD Keypad ● RS232 / 485 ● Pulse Output ● Alarms

VALVES

Barstock

Brass or Stainless ● Standard or High Precision

PTFE

Chemically Inert ● Needle or Metering

Proportionating Solenoid

Stainless ● For Controlling Gas or Liquid Flow

● Pulse width Modulated

SMV ● Stepping Motor Valve

PERISTALTIC PUMPS

Fixed RPM Pumps

Pump Heads

Tubing Pumps

Variable Speeds

Dispensing Pumps

Flexible Tubings