

AALBORG®

VALVES



TABLE OF CONTENTS

BARSTOCK VALVES **PAGE 1**

PTFE NEEDLE VALVES **PAGE 4**

PTFE NEEDLE VALVES 6mm ORIFICE **PAGE 7**

PROPORTIONATING VALVES **PAGE 8**

PULSE WIDTH MODULATED DRIVER **PAGE 11**

STEPPING MOTOR VALVES **PAGE 13**

BARSTOCK VALVES



Designed for controlling very low flow rates of liquids and gases, MFV™ Barstock valves are available in seven conveniently overlapping orifice-needle sizes.

BARSTOCK METERING VALVES MFV™

Offered in straight (T) and 90 degree (L) flow patterns, the MFV™ Barstock Valve includes a “non-rising stem” design, it’s unique non-rotating needle is cylindrical with a precision ground tapered metering surface. The needle moves in a rectilinear fashion which accounts for its desirable sixteen- turn high resolution attribute. Hysteresis is virtually eliminated due to the needle design and the closely fitting fine thread on its adjustment plunger. The valve body is precision machined chrome plated brass or type 316 stainless steel.

design features

- ✓ Virtually free of hysteresis (see-sawing).
- ✓ Bubble tight shutoff.
- ✓ Straight or 90 degree flow patterns.
- ✓ Brass or 316 stainless steel high resolution.
- ✓ Sixteen turns to full open.

SPECIFICATIONS

MAXIMUM PRESSURE	500 psig (3792 kPa).
MAXIMUM TEMPERATURE	180 °F (82 °C) -brass. 250 °F (121 °C).
VALVE STEM	Sixteen turns, non-rising type.

**MATERIALS OF CONSTRUCTION

BODY	Chrome plated brass or 316 stainless steel.
VALVE NEEDLE	316 stainless steel.
ORIFICE	316 stainless steel with PTFE liner for valve sizes 1, 2 and 3; PCTFE for valve sizes 4,5,6 and 7.
O-RINGS	Buna-N® (brass valves). Viton® (stainless valves).

***The selection of materials of construction, is the responsibility of the customer. The company accepts no liability.*

BARSTOCK VALVES

Configure and Order Online: [Barstock Metering Valves MFV™](#)

ORDERING INFORMATION BARSTOCK METERING VALVES MFV™						
MODEL NUMBER	FLOW PATTERN	MATERIAL	MAXIMUM FLOW [mL/min]		ORIFICE [in]	CV
			Air	Water		
VM1-BB-1A	Straight	Brass	200	6	0.042	0.0005
VM2-BB-1A	Straight	Brass	400	12	0.042	0.001
VM3-BB-1A	Straight	Brass	1000	30	0.042	0.0025
VM4-BB-1A	Straight	Brass	2500	70	0.093	0.0061
VM5-BB-1A	Straight	Brass	6200	200	0.093	0.016
VM6-BB-1A	Straight	Brass	21500	650	0.093	0.054
VM7-BB-1A	Straight	Brass	46090	1410	0.093	0.118
VM1-SV-2A	Straight	Stainless	200	6	0.042	0.0005
VM2-SV-2A	Straight	Stainless	400	12	0.042	0.001
VM3-SV-2A	Straight	Stainless	1000	30	0.042	0.0025
VM4-SV-2A	Straight	Stainless	2500	70	0.093	0.0061
VM5-SV-2A	Straight	Stainless	6200	200	0.093	0.016
VM6-SV-2A	Straight	Stainless	21500	650	0.093	0.054
VM7-SV-2A	Straight	Stainless	46090	1410	0.093	0.118
VM1-BB-6A	90 degree	Brass	200	6	0.042	0.0005
VM2-BB-6A	90 degree	Brass	400	12	0.042	0.001
VM3-BB-6A	90 degree	Brass	1000	30	0.042	0.0025
VM4-BB-6A	90 degree	Brass	2500	70	0.093	0.0061
VM5-BB-6A	90 degree	Brass	6200	200	0.093	0.016
VM6-BB-6A	90 degree	Brass	21500	650	0.093	0.054
VM7-BB-6A	90 degree	Brass	46090	1410	0.093	0.118
VM1-SV-7A	90 degree	Stainless	200	6	0.042	0.0005
VM2-SV-7A	90 degree	Stainless	400	12	0.042	0.001
VM3-SV-7A	90 degree	Stainless	1000	30	0.042	0.0025
VM4-SV-7A	90 degree	Stainless	2500	70	0.093	0.0061
VM5-SV-7A	90 degree	Stainless	6200	200	0.093	0.016
VM6-SV-7A	90 degree	Stainless	21500	650	0.093	0.054
VM7-SV-7A	90 degree	Stainless	46090	1410	0.093	0.118

Note: Based on 10psig(69 kPa) inlet pressure and atmospheric exhaust.

BARSTOCK VALVES

Designed for controlling a broad range of flow rates of liquids and gases, CV™ Utility valves are available in three conveniently overlapping orifice-needle sizes.

BARSTOCK \ UTILITY VALVES CV™

These versatile, rugged and reliable valves are suitable for laboratory instrumentation, bench top or OEM flow control purposes.

CV™ Valve-Straight Flow



CV™ Valve-90 deg Flow

SPECIFICATIONS

MAXIMUM PRESSURE	500 psig (3792 kPa).
MAXIMUM TEMPERATURE	180 °F (82 °C) - (brass valves). 250 °F (121 °C) - (stainless valves).

Valves are offered in straight (T) and 90 degree (L) flow patterns. All valves are supplied with 1/8" FNPT inlet and outlet ports.

Valve cartridges are also interchangeable with built-in valves of Aalborg's series of P, T, S, and G flow meter product line.

The valve body is precision machined chrome plated brass or type 316 stainless steel.

**MATERIALS OF CONSTRUCTION

BODY	Chrome Plated Brass Or 316 Stainless Steel.
VALVE NEEDLE	316 Stainless Steel.
ORIFICE	KEL-F.
O-RINGS	Buna® (Brass valves). FKM (Stainless Valves).

**The selection of materials of construction, is the responsibility of the customer. The company accepts no liability.

design features

- ✓ Bubble tight shutoff.
- ✓ Straight or 90 degree flow patterns.
- ✓ Brass or 316 stainless steel.

Configure and Order Online: [Barstock Utility Valves CV™](#)

ORDERING INFORMATION BARSTOCK UTILITY VALVES CV™

MODEL NUMBER	FLOW PATTERN	MATERIAL	MAXIMUM FLOW [mL/min]		ORIFICE [in]	Cv
			Air	Water		
VCL-BB-1A	Straight	Brass	5000	350	0.052	0.03
VCL-SV-2A	Straight	Stainless	5000	350	0.052	0.03
VCL-BB-6A	90 degree	Brass	5000	350	0.052	0.03
VCL-SV-7A	90 degree	Stainless	5000	350	0.052	0.03
VCM-BB-1A	Straight	Brass	20000	1200	0.082	0.10
VCM-SV-2A	Straight	Stainless	20000	1200	0.082	0.10
VCM-BB-6A	90 degree	Brass	20000	1200	0.082	0.10
VCM-SV-7A	90 degree	Stainless	20000	1200	0.082	0.10
VCH-BB-1A	Straight	Brass	60000	3500	0.120	0.30
VCH-SV-2A	Straight	Stainless	60000	3500	0.120	0.30
VCH-BB-6A	90 degree	Brass	60000	3500	0.120	0.30
VCH-SV-7A	90 degree	Stainless	60000	3500	0.120	0.30

Note: Based on 10psig (69 kPa) inlet pressure and atmospheric exhaust.

PTFE NEEDLE VALVES

design features

- ✓ Fluids contact PTFE and PEEK only.
- ✓ Structurally Rigid Metal Shell.
- ✓ One PTFE o-ring.
- ✓ Simplicity only seven components.



PTFE Needle valve with Stainless Shell and FNPT Fittings

Note: Based on 10psig (69 kPa) inlet pressure and atmospheric exhaust.

Configure and Order Online: [PTFE Needle Valves](#)

ORDERING INFORMATION PTFE NEEDLE VALVES

MODEL NUMBER	MAXIMUM FLOW [ml/min]		CV	NON WETTED MATERIALS		CONNECTIONS
	AIR	WATER		SHELL	BUSHING	
VCL-TT-0A	2400	130	0.011	Aluminum	Brass	1/8" FNPT
VCH-TT-0A	55000	2800	0.250	Aluminum	Brass	1/8" FNPT
VCL-TT-0F	2400	130	0.011	Aluminum	Brass	1/4" Comp.
VCH-TT-0F	55000	2800	0.250	Aluminum	Brass	1/4" Comp.
VCL-TT-0G	2400	130	0.011	Aluminum	Brass	0.390 O.D. Glass Nipples
VCH-TT-0G	55000	2800	0.250	Aluminum	Brass	0.390 O.D. Glass Nipples
VCL-TT-2A	2400	130	0.011	Stainless	Stainless	1/8" FNPT
VCH-TT-2A	55000	2800	0.250	Stainless	Stainless	1/8" FNPT
VCL-TT-2F	2400	130	0.011	Stainless	Stainless	1/4" Comp.
VCH-TT-2F	55000	2800	0.250	Stainless	Stainless	1/4" Comp.
VCL-TT-2G	2400	130	0.011	Stainless	Stainless	0.390 O.D. Glass Nipples
VCH-TT-2G	55000	2800	0.250	Stainless	Stainless	0.390 O.D. Glass Nipples

PTFE NEEDLE VALVES



PTFE Metering Valve

MVT™ Metering valves are constructed of PTFE and PEEK materials.

Non-fluid contacting external parts are made of anodized aluminum. Valves are offered in three conveniently overlapping flow ranges. Safety handle prevents over tightening and facilitates fine metered regulation. MVT™ valves are useful in regulating the flow of corrosive gases and liquids.

They may be used in pressure or non-critical vacuum service and serve as bubble tight shutoff valves.

SPECIFICATIONS	
MAXIMUM PRESSURE	75 psig (517 kPa)
MAXIMUM TEMPERATURE	150 °F (65 °C)
ORIFICE SIZE	0.125" diameter (3.175 mm)
NUMBER OF TURNS TO FULLY OPEN	Eight.
STEM	Non-rising type.
FLUID CONTACTING COMPONENTS	Body /o-ring-PTFE. Valve spindle-PEEK.
NON-FLUID CONTACTING COMPONENTS	Shell + Handle - Aluminum (anodized).

* Based on 10 psig (69 kPa) inlet pressure and atmospheric exhaust.

Configure and Order Online: [PTFE Metering Valves](#)

ORDERING INFORMATION PTFE METERING VALVES				
MODEL NUMBER	MAXIMUM FLOW [ml/min]		Cv	CONNECTIONS
	Air	Water		
VM1-TT-0A	600	36	0.003	1/8" FNPT
VM3-TT-0A	3000	180	0.015	1/8" FNPT
VM6-TT-0A	30000	1800	0.150	1/8" FNPT
VM1-TT-0F	600	36	0.003	1/4" Comp.
VM3-TT-0F	3000	180	0.015	1/4" Comp.
VM6-TT-0F	30000	1800	0.150	1/4" Comp.
VM1-TT-0G	600	36	0.003	0.390 O.D. Glass Nipples
VM3-TT-0G	3000	180	0.015	0.390 O.D. Glass Nipples
VM6-TT-0G	30000	1800	0.150	0.390 O.D. Glass Nipples

These compact and reliable PTFE needle valves are designed for laboratory and industrial applications for regulating corrosive gases and liquids or for high purity service.

They may also be used as shut off valves.



PTFE Needle valve with Aluminum Shell and Glass Nipples

Pliant PTFE bodies of the valves are reinforced by structurally rigid metallic shells. Fluids contact only PTFE and PEEK materials. Shells are made of anodized aluminum or type 316 stainless steel and bushings are made of plated brass or 316 stainless steel. Where externally corrosive conditions exist stainless steel is recommended.

Valve spindles are made of rigid PEEK to minimize the undesirable material “creeping” normally associated with PTFE. PTFE valves are designed for relatively high flow ranges while still performing well in low flow rates. Valves may be used in pressure or non-critical vacuum service.

The simplicity of design - there are only seven components (including a single PTFE o-ring) - assures reliability and minimizes sources of leakage. It takes seconds to disassemble the valve for cleaning and maintenance. The PTFE o-ring is radially compressed and due to this unique design feature the degree of compression may be adjusted without disassembly by tightening the hexagonal bushing.

SPECIFICATIONS

MAXIMUM PRESSURE	75 psig (517 kPa)
MAXIMUM TEMPERATURE	150 °F (65 °C)
ORIFICE SIZE	0.125" diameter (3.175 mm)
**MATERIALS OF CONSTRUCTION FLUID CONTACTING	
	Body and o-ring-PTFE. Valve spindle-PEEK.
NON FLUID CONTACTING	
	Shell - Aluminum (anodized) or 316 stainless steel. Bushing plated brass, or 316 stainless steel. Adjusting Knob-phenolic.

***The selection of materials of construction, is the responsibility of the customer. The company accepts no liability.*

PTFE NEEDLE VALVES 6mm ORIFICE

design features

- ✓ Fluids contact PTFE and PCTFE only.
- ✓ One PTFE o-ring.
- ✓ Simplicity, only six components.

PTFE needle valves are designed for laboratory and industrial applications for regulating corrosive gases and liquids or for high purity service. They may also be used as shut off valves.

Fluids contact only PTFE and PCTFE materials.

Valve spindles are made of rigid PCTFE to minimize the undesirable material “creeping” normally associated with PTFE.

PTFE valves are designed for relatively high flow ranges while still performing well in low flow rates.

Valves may be used in pressure or non-critical vacuum service.

The simplicity of design - there are only six components (including a single PTFE o-ring) - assures reliability and minimizes sources of leakage. It takes seconds to disassemble the valve for cleaning and maintenance.

The PTFE o-ring is radially compressed and due to this unique design feature the degree of compression may be adjusted without disassembly by tightening the bushing.

6mm PTFE Needle Valves



Configure and Order Online: [VT6 PTFE Needle Valve 6mm Orifice](#)

ORDERING INFORMATION FOR VT6 PTFE NEEDLE VALVE 6MM ORIFICE				
MODEL NUMBER	MAXIMUM FLOW LPM		Cv	CONNECTIONS
	Air	Water		
VT6-TT-0	300	9	0.765	3/8" FNPT

Note: Based on 10psig (69 kPa) inlet pressure and atmospheric exhaust.

SPECIFICATIONS	
MAXIMUM PRESSURE	75 psig (517 kPa)
MAXIMUM TEMPERATURE	150 °F (65 °C)
ORIFICE SIZE	6.0 mm (0.250") diameter.
**MATERIALS OF CONSTRUCTION FLUID CONTACTING	
	Body and o-ring-PTFE. Valve spindle-PCTFE.
NON FLUID CONTACTING	Set screws 18-8 stainless steel.

PROPORTIONATING VALVES



PSV
Proportionating
Electromagnetic
Valve

PSV Proportionating Electromagnetic Valves are designed to respond to variable power inputs to proportionately regulate the flow of liquids and gases.

For added safety PSV valves are normally closed (NC) when de-energized. They can also serve as “ON-OFF” valves. For control functions see the PSV-D Driver Module.

Flow is controlled by increasing or decreasing the voltage applied to the coil. This causes a magnetic force which raises the core and allows gas to flow.

PSV valves, constructed of stainless steel are available in five different sizes covering flow ranges from 3.5 L/min - 100 L/min air and 125 mL/min - 2.85 L/min H₂O.

Design Features

- Leak Integrity 1×10^{-9} mL/sec.
- Rigid metallic construction.
- Gas and liquids.
- Max pressure of 1000 psig (68.9 bars).

Principle of Operation

A variable stroke electromagnetic valve featuring a valve seat design which permits increasing or decreasing flow rates of liquids or gases through it in proportion to variable input power.

Regulator Systems

Complete flow regulating systems include a PSV electromagnetic valve connected to a pulse width modulated PSV-D Driver Module. For details see Driver Module description.

MAX FLOW RATES AND CV VALUES FOR PSV

MODEL NUMBER	ORIFICE SIZE		Cv	*MAXIMUM FLOW [mL/min]	
	[in]	[mm]		AIR	WATER
PSV1S-VA	0.02	0.51	0.009	3500	125
PSV2S-VA	0.04	1.02	0.033	13000	400
PSV3S-VA	0.055	1.4	0.055	21500	700
PSV4S-VA	0.063	1.6	0.068	25000	850
PSV5S-VA	0.125	3.18	0.24	100000	2850

* Based on 10 psig (690 mbar) differential pressure for sizes 1-4 20 PSIG 1380 mBar for size 5.

SPECIFICATIONS

POWER INPUT:	0-30Vdc.
MAXIMUM POWER REQUIRED:	400 mA.
TYPE OF OPERATION:	Normally closed (NC) when de-energized.
CONNECTIONS:	1/4" Compression fittings optional 3/8" (1/8" with PSV1, 2 or 3).
** MATERIALS IN FLUID CONTACT:	Types 316 and 416 stainless steel, Viton® O-rings. Optional O-rings: Buna®, EPR and Kalrez®.
MAXIMUM PRESSURE:	1000 psig (6897 kPa).
MAXIMUM DIFFERENTIAL PRESSURE:	50 psid (345 kPa).
LEAK INTEGRITY:	1 X 10 ⁻⁹ smL/sec Helium individually tested.
FLUID TEMPERATURE:	14 °F to 122 °F (-10 °C to 50 °C).
MAXIMUM TEMPERATURE (typical):	174 °F (79 °C) inside, 130 °F (54 °C) outside surface at 24Vdc.

**The selection of materials of construction, is the responsibility of the customer. The company accepts no liability.

PROPORTIONATING VALVES

Cross Sectional View
PSV Valve

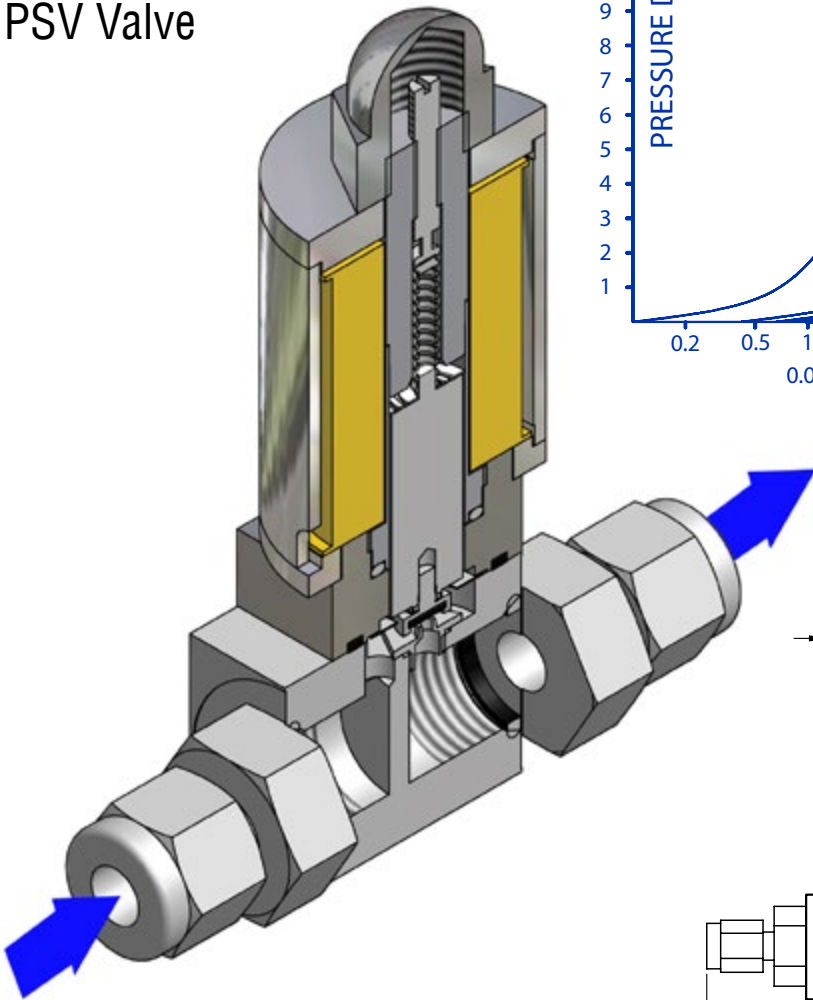

PSV Proportionating
Electromagnetic Valves

Pressure Drops Across PSV Valves

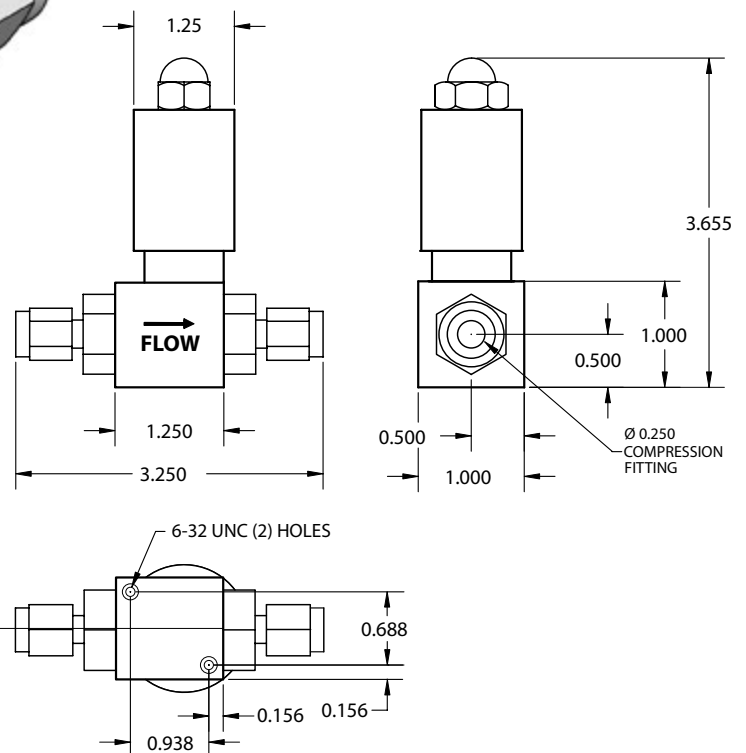
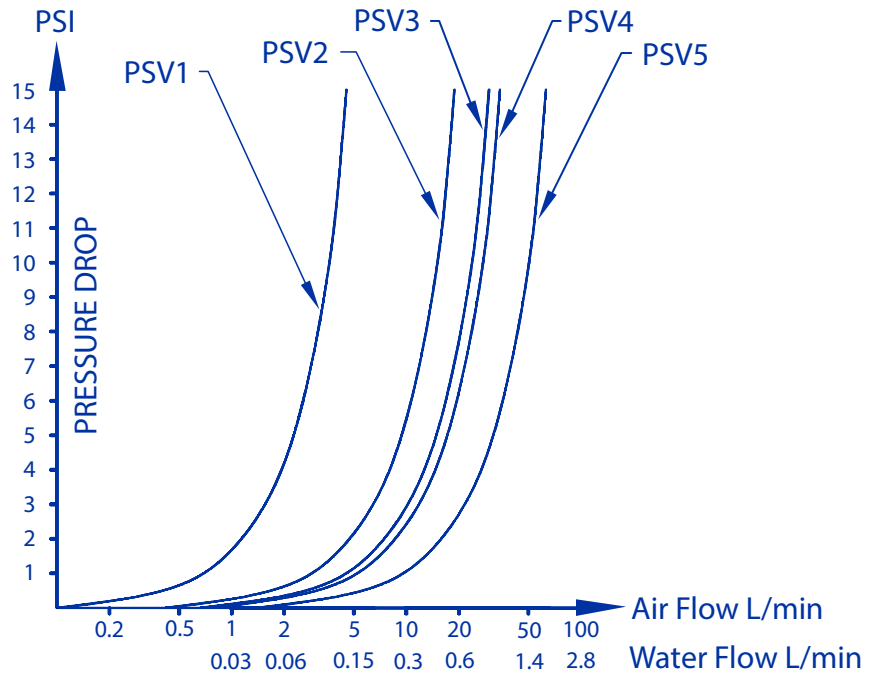

ORDERING INFORMATION PROPORTIONATING VALVES

Configure and Order Online: [PSV Proportional Solenoid Valve](#)

PSV	MODEL												
	<table border="1"> <tr> <th colspan="2">SERIES</th> </tr> <tr> <td>1</td> <td></td> </tr> <tr> <td>2</td> <td></td> </tr> <tr> <td>3</td> <td></td> </tr> <tr> <td>4</td> <td></td> </tr> <tr> <td>5</td> <td></td> </tr> </table>	SERIES		1		2		3		4		5	
SERIES													
1													
2													
3													
4													
5													
	<table border="1"> <tr> <th colspan="2">MATERIAL</th> </tr> <tr> <td>S</td> <td>Stainless Steel</td> </tr> </table>	MATERIAL		S	Stainless Steel								
MATERIAL													
S	Stainless Steel												
	<table border="1"> <tr> <th colspan="2">SEALS</th> </tr> <tr> <td>V</td> <td>Viton®</td> </tr> <tr> <td>B</td> <td>Buna®</td> </tr> <tr> <td>E</td> <td>EPR</td> </tr> <tr> <td>T</td> <td>PTFE / Kalrez®</td> </tr> </table>	SEALS		V	Viton®	B	Buna®	E	EPR	T	PTFE / Kalrez®		
SEALS													
V	Viton®												
B	Buna®												
E	EPR												
T	PTFE / Kalrez®												
	<table border="1"> <tr> <th colspan="2">FITTINGS</th> </tr> <tr> <td>A</td> <td>1/4" Compression</td> </tr> <tr> <td>B</td> <td>1/8" Compression (1/8" with PSV1, 2 or 3)</td> </tr> <tr> <td>D</td> <td>3/8" Compression</td> </tr> <tr> <td>X</td> <td>Special</td> </tr> </table>	FITTINGS		A	1/4" Compression	B	1/8" Compression (1/8" with PSV1, 2 or 3)	D	3/8" Compression	X	Special		
FITTINGS													
A	1/4" Compression												
B	1/8" Compression (1/8" with PSV1, 2 or 3)												
D	3/8" Compression												
X	Special												

PSV	4	S	—	V	A
-----	---	---	---	---	---

EXAMPLE: PSV4S-VA

PSV4 stainless steel, Viton® seals with 1/4" compression fittings.

PULSE WIDTH MODULATED DRIVER

PSV-D

Pulse width modulated PSV-D Driver Modules regulate the power supplied to PSV Regulating valves based on a reference signal.

Set-point signals, 0-5 Vdc or 4-20 mA, input are employed to control the output pulse width modulated voltage at a fixed frequency ($\gg 30\text{KHz}$) and amplitude. Incoming power to the valve coil is applied and discontinued for predetermined periods of time by a low loss solid state switching element.

As incoming power is applied, energy in the inductive coils increases and when it is discontinued energy stored in the coil maintains the magnetic flux level required to hold flow at the controlled rate. This cycle takes place many thousands of times per second.

The wide range of power input features conveniently accommodates 12 to 32 Vdc sources.

The Auto-Select feature of the Driver Module recognizes the type of reference signal received and defaults to 0 - 5 Vdc if both signals are provided.

Pulse Width Modulated Driver Module



Shown with PSV Valve

Dimensions Pulse Width Modulated Driver Module

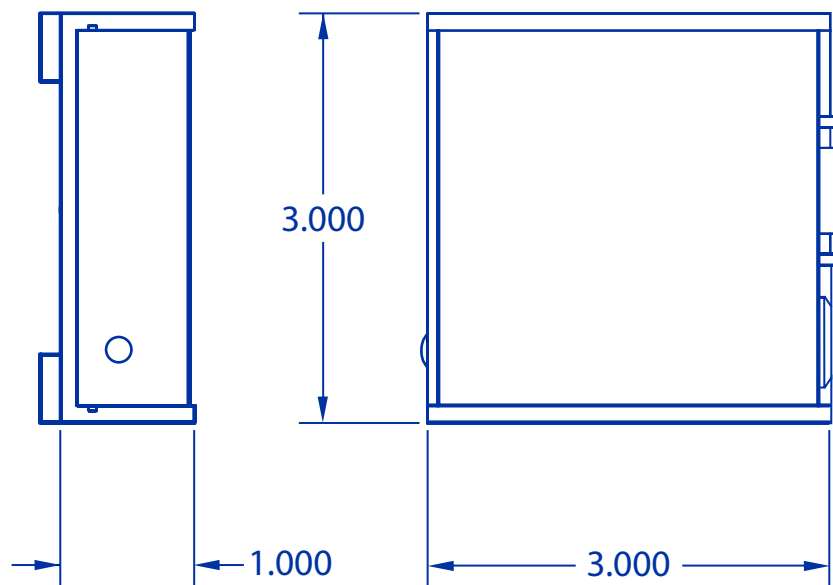

ORDERING INFORMATION PULSE WIDTH MODULATED DRIVER MODULES

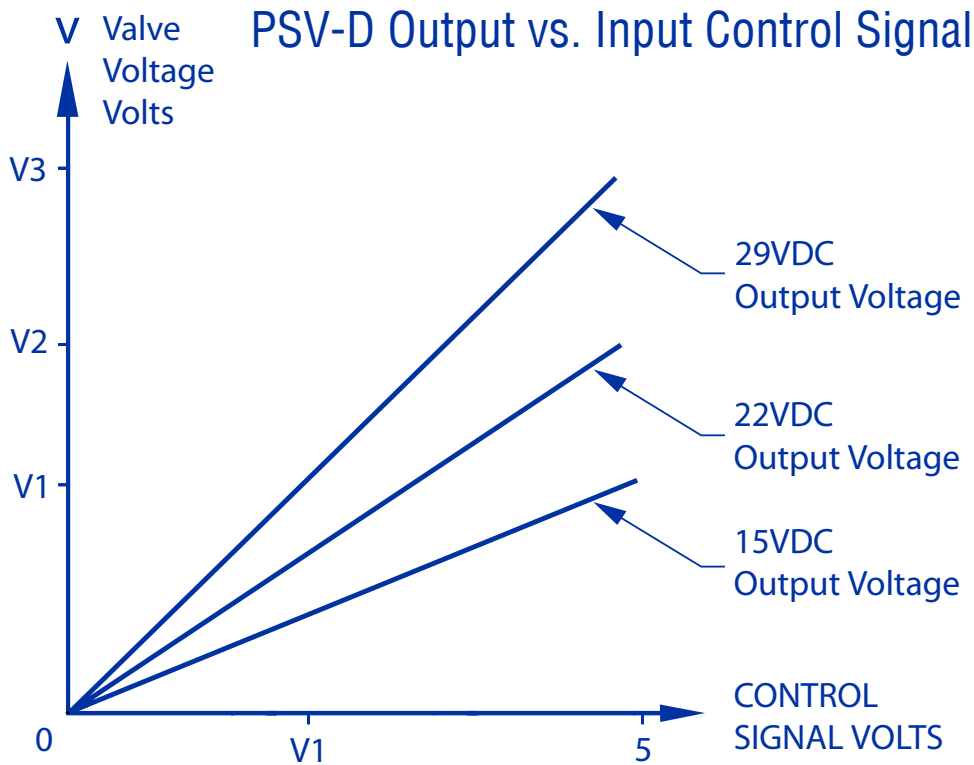

Jumper selectable output power allows a choice of dc voltage range for cooler more efficient operation, as a function of flow rates.

Internal resettable fuse protects electronics and rectifier circuits, prevents polarity reversal damage.

The maximum output voltage supplied to the PSV Valve can be set or changed in the field to allow for optimal use of the input reference signal to output voltage based on the specific flow rate and operating pressure applied to the valve.

SPECIFICATIONS

CONNECTION:	9-pin male "D" subconnector for input/output signals.
POWER INPUT REQUIRED:	+12 to 30 Vdc 1A @ 12 Vdc, 0.5A (not supplied) @ 24 Vdc via 9-pin "D"-connector or dc power jack (center positive).
INPUT SIGNAL:	Auto-Select feature allows circuit to recognize which analog input reference (0 to 5 Vdc or 4-20 mA) signal is provided.
TTL ON/OFF:	Jumper selectable LOW (0 Vdc) OFF-HIGH (5 Vdc) on, or reverse, to select valve ON/OFF status.
VALVE OUTPUT POWER:	Jumper selectable to +15, +22, and +29 Vdc with adjacent potentiometer to obtain ± 2 Vdc.
FUSE RATING:	An internal resettable 1.6A fuse protects the electronics on the power input.
POLARITY PROTECTION:	Internal rectifier circuit protects from reversed polarity on the power input.
OPERATING TEMPERATURE:	32 °F (0 °C) to 122 °F (50 °C).
DIMENSIONS:	3" (7.62mm) wide x 3" (7.62mm) deep x 1" (25.4mm) high.
CE COMPLIANCE :	EMC Directive 89/336/EEC EN55011:1991 Group 1, Class A EN50082-2:1995.

Configure and Order Online: [Pulse Width Modulated Driver Modules](#)

ORDERING INFORMATION FOR PSV-D	
MODEL	
PSV-D	Proportionating Solenoid Valve Driver

PSV-D

ACCESSORIES FOR FOR PSVD DRIVER MODULE

PS-PSV-110NA-4	Power Supply, 110vac/24 Vdc /North America
PS-PSV-230EU-4	Power Supply, 230vac/24 Vdc /Europe
PS-PSV-240AU-4	Power Supply 240vac/24 Vdc /Australia
PS-PSV-240UK-4	Power Supply 240vac/24 Vdc /United Kingdom
CBL-DP9-6	Female 9 pin D-connector with 6 ft.cable

STEPPING MOTOR VALVES

Design Features

- High precision two-way metering valves in aluminum or 316 SS for air/water.
- Unparalleled precision and resolution in controlling flow rates
- (0.00025" per step resolution standard, 0.000125" optional).
- Operate continuously without overheating.
- Eliminates coil heating problems associated with solenoid designs.

SMV Stepping Motor Valves



SMV Stepping Motor Valve Dimensions

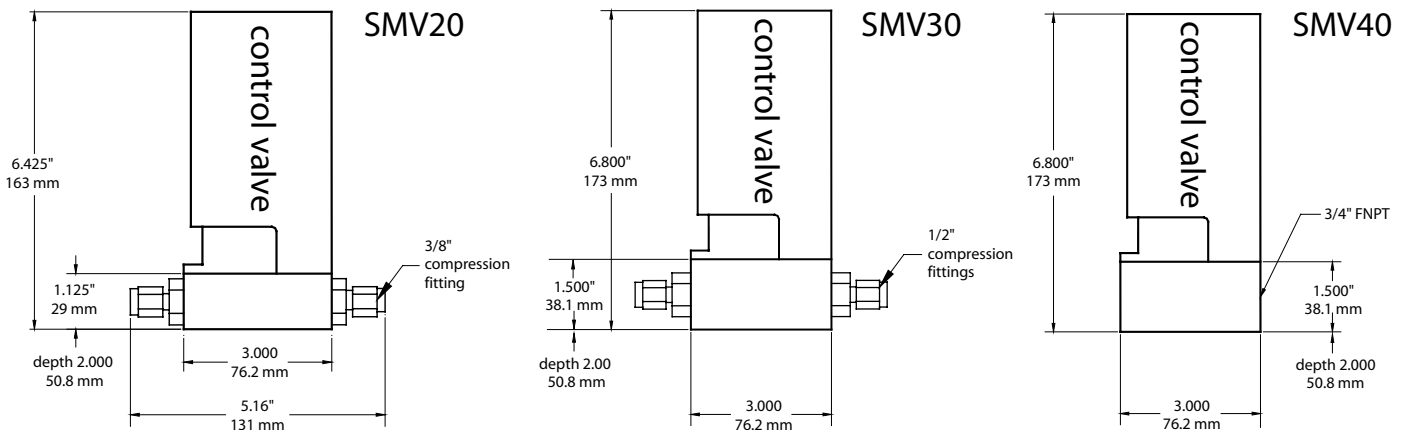

STEPPING MOTOR VALVES

SPECIFICATIONS	
ALUMINUM MODELS:	Aluminum housings and valve blocks, Viton® O-Rings, PFA closing pins.
STAINLESS STEEL / PTFE MODELS:	316 stainless steel valve blocks, PTFE-lined aluminum housing blocks, Viton® O-Rings, and PFA closing pins.
MAXIMUM FLOW RATES:	1000 L/min (air), 28 L/min (H ₂ O).
CONNECTIONS:	3/8", 1/2", compression and 3/4" FNPT.
ELECTRICAL CONNECTIONS:	9-pin "D"-connector, located at the side of the valve.
POWER INPUT:	12Vdc @ 800 mA, or +24 Vdc @ 600 mA, protected by a 1600mA resettable fuse.
DIRECTIONAL CONTROL SIGNAL:	12Vdc CMOS compatible logic level signal (10K input impedance). (Logic High \geq 7.5 Vdc, Low $<$ 2.3 Vdc).
SPEED CONTROL SIGNAL:	Analog 0 to 2.5 Vdc (100K input impedance). ON/OFF override: 12 Vdc CMOS low active level to pins. 7 and 3 (10K input impedance).
RESPONSE TIME:	100ms time constant.
PRESSURE DROP AT MAX. FLOW:	700 to 1000) mbars 10 to 15 psid.
MAXIMUM OPERATING PRESSURE:	500 psig (35 bars).
MAXIMUM DIFFERENTIAL PRESSURE:	40 psig (2.7 bars).
GAS & AMBIENT TEMPERATURE:	32 °F to 122 °F (0 °C to 50 °C).

Operation

When the "DIRECTION" is set LOW (GND) the valve spindle travels downward (closes), when it is set HIGH, the valve spindle moves upward (opens). The "SPEED" voltage on pin 4 determines how quickly the valve opens or closes. The signal amplitude for the "SPEED" control signal must remain within the limits of 0 to +2.5 Vdc. It may be necessary to override "DIRECTION" and "SPEED" signals with the preset (2.75 Vdc) speed control signal.

This can be accomplished with valve CLOSE and PURGE control signals (open collector NPN compatible). In order to CLOSE the valve, pin 3 on the 9-pin "D"-connector has to be connected to GND (pin 2). A GREEN light on the top of the valve will indicate a CLOSED valve condition. In order to PURGE the valve, pin 7 on the 9-pin "D"-connector has to be connected to GND (pin 2). A RED light on the top of the valve will indicate a fully OPEN valve condition. During normal operation the valve remains in the last position as it is deenergized.

After powering up, the valve will be automatically closed within the first 10 seconds and after that resumes control operation. Operating power and valve control signals are supplied via the "D"-connector.

General Description

A line of electronic two-way metering needle valves is presented. High precision linear stepping motors drive the valve spindle.

The resolution of the stepping motor driven needles is 0.00025"/step standard. Optional 0.000125"/step resolution available. Low differential pressure valves, may be operated continuously (100% duty cycle). Valves stay in position as when de-energized.

Advantages over solenoid operated valves include cool operations, i.e. there are no control operating problems due to coils heating up, extremely fine resolution, very low differential pressures and high operating pressures. Valves are controllable by CMOS 12 Vdc compatible logic level and analog 0 to 2.5 Vdc signals.

Configure and Order Online: [SMV Stepping Motor Valve](#)

FLOW RATE FOR SMV							
MODEL NUMBERS	MAXIMUM FLOW RATE				CV	CONNECTIONS	MATERIAL
	AIR		H ₂ O				
	L/min]	[scfh]	[L/min]	gal/min			
SMV20-AVD2	200	424	5.6	1.48	0.336	3/8" compression	Aluminum
SMV20-SVD2	200	424	5.6	1.48	0.336	3/8" compression	Stainless Steel
SMV30-AVE2	500	1060	14.2	3.75	0.855	1/2" compression	Aluminum
SMV30-SVF2	500	1060	14.2	3.75	0.855	1/2" compression	Stainless Steel
SMV40-AVF2	1000	2119	28	7.4	1.735	3/4" FNPT	Aluminum
SMV40-SVF2	1000	2119	28	7.4	1.735	3/4" FNPT	Stainless Steel