

OPERATING MANUAL

Hi-Lo Optical Sensor Switch

**P Style Meter
with Optical Sensor
Switches**

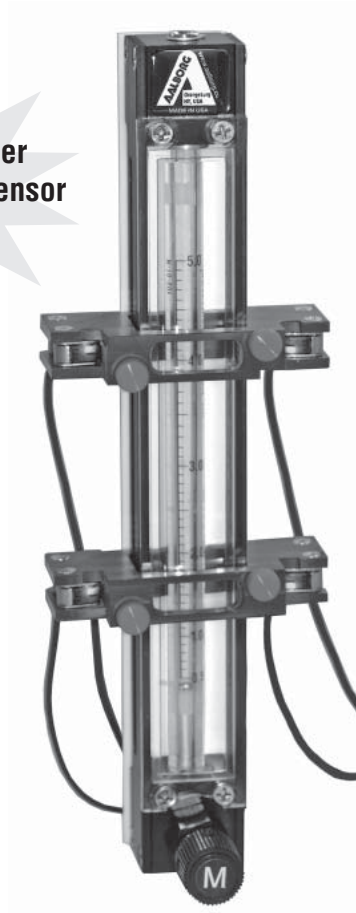

AALBORG®



⚠ CAUTION:

This product is not intended to be used in life support applications!

GENERAL DESCRIPTION

The Optical Sensor Switch Hi-Lo is a non-invasive means for detection of a HI or LOW flow. This set of sensors is ideal for signaling an alarm, cutoff valve, or other device when the float passes the detector (alarm, valve, etc. are not included). The Optical Sensor Switch helps protect processes and equipment from damage caused by extreme flow rates.

Its compact design and ease of operation make it a non-obtrusive, simple to use addition to your flow meter. Perfect for OEM applications, use whenever maximum or minimum flow levels need to be monitored automatically. It also can be used in conjunction with a control relay to power alternate equipment or monitoring devices.



NOTE: Used in conjunction with P, S and T Style Flow Meters.

PRINCIPLE OF OPERATION

The Optical Sensor Switch Hi-Lo consists of two self-contained mini-slim photo-electric sensors (Thru-beam type). Every sensor has a transmitter and receiver. Two sets of sensors are mounted on two solid carriers on opposite sides of the flow tube. The float inside the flow tube is detected as it passes across the beam of light. The sensors can be used to detect the float passage beyond the setpoint of the sensor and can also be set to monitor the float position at a specific level, signaling when the float is outside of the range of the sensor light beam.

TO ORDER A FLOW METER WITH OPTICAL SENSOR SWITCHES



NOTE: To order a flow meter with Hi-Lo Optical Sensor Switches add "02-" to P, S, or T Model Numbers. Example: 02-P11A4-BA0-032-41-ST-VN.

ORDERING INFORMATION FOR OPTICAL SENSOR SWITCH ACCESSORY	
PART NUMBER	DESCRIPTION
OSV2-6-P	Hi-Lo Optical Sensor Switch for 65mm P Style Meter
OSV2-1-P	Hi-Lo Optical Sensor Switch for 150mm P Style Meter
OSV2-6-S	Hi-Lo Optical Sensor Switch for 65mm S Style Meter
OSV2-1-S	Hi-Lo Optical Sensor Switch for 150mm S Style Meter
OSV2-6-T	Hi-Lo Optical Sensor Switch for 65mm T Style Meter
OSV2-1-T	Hi-Lo Optical Sensor Switch for 150mm T Style Meter

SPECIFICATIONS	
MODE OF DETECTION	Red LED Thrubeam type.
POWER REQUIREMENTS	10 to 30 Vdc @50 mA max.
OUTPUT TRANSISTORS	NPN source up to 50 mA.
RESPONSE TIME	0.5 ms.
LIGHT IMMUNITY	4 Element, point light source, red LED 650 nm.
AMBIENT TEMPERATURE	25 degree C to +55 degree C.
SENSOR CONSTRUCTION	Heavy duty metal housing, IP-67 protection.
SENSOR CERTIFICATION	
UL	File #: E301717; Category: NRKH2/NRKH8; Enclosure type: 1 (UL50)
CE:EMC DIRECTIVE (2004/108/EC)	Applicable Standard: EMI: EN60947-5-2 Class A/EMS:EN60947-5-2

Each sensor consists of two parts: transmitter and receiver. When power is properly connected the power supply indicator (green LED) on the transmitter is constantly on.

The receiver has two indicators:

Stable operation indicator (green LED) turns on with a stable incoming beam and with a stable blocked light. Output indicator (orange LED) turns on when the beam from emitter is blocked by the float.

TROUBLESHOOTING		
PROBLEM	CAUSE	CHECK & ACTION
All indicators are off.	The power supply is not connected.	Connect the power supply.
The output indicators turn on and off but output does not turn on or off.	Incorrect wiring.	Check the wiring for the output wires.
	The input device has failed. Sensor output has failed or an output wire is broken.	Try connecting the sensor output to a separate input device.
The output indicator is flashing.	Overcurrent has passed through an output.	Check that the rated current for the input device has not exceeded 50 mA. Check that the output wires are not shorted by any other wires.
	The sensor is affected by ambient light.	When there are light sources nearby (sensors, lighting), adjust the sensor installation.

PR-M

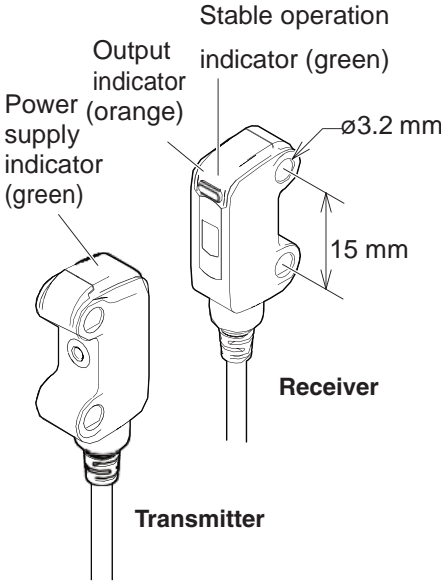

MOMENTARY OR LATCH OPERATION

Optionally the, Hi-Lo Optical Sensor Switch could be supplied with OSSM Module, allowing each sensor to be separately set for momentary or latch operation of buzzer, LED and relay.

The OSSM module is equipped with the 8 position DIP switch and requires a +12 VDC power supply with a minimum current rating of 250 mA.



OUTPUT WIRING DIAGRAM

• **NPN**

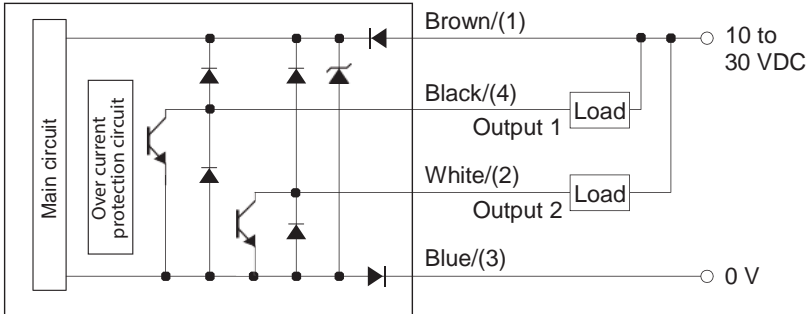

WARRANTY

Aalborg® Optical Sensor Switch is warranted against parts and workmanship for a period of one year from the date of purchase. Calibrations are warranted for up to six months after date of purchase, provided calibration seals have not been tampered with. It is assumed that equipment selected by the customer is constructed of materials compatible with gases used. Proper selection is the responsibility of the customer. It is understood that gases under pressure present inherent hazards to the user and to equipment, and it is deemed the responsibility of the customer that only operators with basic knowledge of the equipment and its limitations are permitted to control and operate the equipment covered by this warranty. Anything to the contrary will automatically void the liability of Aalborg® and the provisions of this warranty. Defective products will be repaired or replaced solely at the discretion of Aalborg® at no charge. Shipping charges are borne by the customer. This warranty is void if the equipment is damaged by accident or misuse, or has been repaired or modified by anyone other than Aalborg® or factory authorized service facility. This warranty defines the obligation of Aalborg® and no other warranties expressed or implied are recognized.

ASIAN SERVICE FACILITY

Authorized Repair and Service Facility for Aalborg Thermal Mass Flow Systems

AALBORG-Beijing Comity MEASURE & CONTROL CO.

Floor 1 Tower B Jindayuan Office Building
Xisanqi, Hai Dian District, Beijing, China

Phone: 86-10-6295-0464, 86-10-6295-0465

Fax: 86-10-6295-0466

Website: <http://www.comity-tec.com>

EUROPEAN SERVICE FACILITY

Authorized Repair and Service Facility for Aalborg Thermal Mass Flow Systems

AALBORG-ANALYT-MTC MESSTECHNIK GMBH

Klosterrunsstraße 18

P.O. Box 1321

Müllheim D-79379 Germany

Telefon: +49 (0)7631 5545

Fax: +49 (0)7631 14740

Website: www.analyt-mtc.de

e-mail: info@analyt-mtc.de

175, avenue d'Alsace

68000 COLMAR

Tel: 03 89 41 47 78

Fax: 03 89 41 59 88

e-mail: ANALYT_MTC@T-online.de

Products Manufactured By Aalborg

ROTAMETERS

Single Tube

Aluminum / Brass / Stainless • Interchangeable Glass Flow Tubes • Optional Valves

Multiple Tube

Two to Six Channels • Aluminum or Stainless

PTFE Single and Multiple Tube

Chemically Inert • 1 to 4 Channels • Interchangeable Glass Flow tubes

PTFE - PFA

Chemically Inert • Low to Medium Flow of Corrosive Liquids with PFA Flow Tube

Kits

Aluminum / Stainless / PTFE • Including Five Glass Flow Tubes and a Set of Floats

Gas Proportioners

Aluminum / Stainless • Used for Blending Two or Three Gases

Medium Range Glass Safety Shield • Dual Air and Water Scale

Optical Sensor Switch

Non-Invasive Means for Detection of a High or Low Flow

High Flow Industrial Stainless Steel Flow Meters

Heavy Duty Stainless Steel • Direct Reading Air and Water Scales

VALVES

Barstock

Brass or Stainless • Standard or High Precision

PTFE

Chemically Inert • Needle or Metering

Proportionating Solenoid

Stainless • For Controlling Gas or Liquid Flow

• Pulse width Modulated

SMV • Stepping Motor Valve

PERISTALTIC PUMPS

Fixed RPM Pumps

Pump Heads

Tubing Pumps

Variable Speeds

Dispensing Pumps

Flexible Tubings

ELECTRONIC METERS & CONTROLLERS

Low Cost Mass Flow Meters

Aluminum or Stainless • With or Without LCD Readout

Low Cost Mass Flow Controllers

Aluminum or Stainless • With or Without LCD Readout

Mass Flow Controllers

Stainless • One to Four Channel Systems

Digital Mass Flow Controllers

Auto Zero • Totalizer • Alarms • Built in RS485

Multi Parameter Digital Mass Flow Meters

Displays Flow Pressure and Temperature

Paddle Wheel Meters

For Liquids • Optional Temperature Measurements

Vortex In-Line and Insertion Flow Meters

Steam / Liquid and Gas Service

Smart Rate / Totalizer / Signal Conditioner

LCD Keypad • RS232 / 485 • Pulse Output = Alarms