

Model **AF** mass flow controllers are designed to indicate flow rates and control set flow rates of gases.

Each of these units incorporates an advanced straight tube sensor in conjunction with flow passage elements constructed of stainless steel.

LCD readouts of command modules are supplied with 0 to 100 percent calibrations. Zero and span adjustments are conveniently accessible from outside of the transmitters.

Design Features

- Rigid metallic construction.
- Maximum pressure of 1000 psig (70 bars).
- 0-5 Vdc or 4-20mA signals.
- Leak integrity 1×10^{-9} smL/sec of helium.
- Accuracy of $\pm 1\%$ F.S.
- Totalizer option.
- Circuit protection.

Principles of Operation

Metered gases are divided into two laminar flow paths -one through the primary flow conduit and the other through a capillary sensor tube.

Both flow conduits are designed to ensure laminar flows and therefore the ratio of their flow rates is constant.

Two precision temperature sensing windings on the sensor tube are heated, and when flow takes place, gas carries heat from the upstream to the downstream windings. The resultant temperature differential is proportional to the change in resistance of the sensor windings.

A Wheatstone bridge design is used to monitor the temperature dependent resistance gradient on the sensor windings which is linearly proportional to the instantaneous rate of flow.

Output signals of 0 to 5Vdc or 4 to 20mA are generated indicating mass molecular based flow rates of the metered gas.

SDPROC and AFC Analog Mass Flow Controller



In AFC mass flow controllers the combined gas streams flow through a proportionating electromagnetic valve with an appropriately selected orifice. The closed loop control circuit continuously monitors the mass flow output and maintains it at the set flow rate.

Flow rates are unaffected by temperature and pressure variations within stated limitations.

Transducer power supply ports are fuse and polarity protected.

AFC mass flow controllers include an electromagnetic control valve that allows the flow to be set to any desired

flow rate within the range of the particular model. The valve is normally closed as a safety feature to ensure that gas flow is shut off in case of a power outage.

AFC mass flow controllers are designed to meter and control flow rates of gases.

AFC mass flow controllers are available with flow ranges from 10 mL/min to 100LPM [N₂]. Gases are connected by means of 1/4", 3/8", or optional 1/8" compression fittings.

These controllers may be used as bench top units or mounted by means of screws in the base.

TABLE 39 - SPECIFICATIONS

ACCURACY:	±1% of FS at calibration temperature and pressure.
CALIBRATIONS:	Performed at standard conditions [14.7 psia (101.4 kPa) and 70 °F (21.1°C)] unless otherwise stated.
REPEATABILITY:	±0.25% of full scale.
TIME CONSTANT:	AFC26: (Q _{max} = 10 L/min): 300 ms. AFC36: (Q _{max} = 50 L/min): 600 ms. AFC46: (Q _{max} = 100 L/min): 600 ms.
RESPONSE TIME:	AFC26: (Q _{max} = 10 L/min): Approximately 1 second to within ±2% of set flow rate for 25% to 100% of full scale flow. AFC36: (Q _{max} = 50 L/min) and AFC46: (Q _{max} =100 L/min): Approximately 2 second to within ±2% of set flow rate or 25% to 100% of full scale flow.
TEMPERATURE COEFFICIENT:	0.1% of full scale/ °C.
PRESSURE COEFFICIENT:	0.01% of full scale/psi (0.07 bar).
OPTIMUM GAS PRESSURE:	25 psig (1.73 bars).
MAXIMUM GAS PRESSURE:	1000 psig (70 bars) maximum. Standard calibration is at 20 psig (1.4 bars) inlet pressure.
MAX. PRESSURE DROP: (at full scale flow)	Refer to Table 41.
GAS AND AMBIENT TEMPERATURE:	32 °F to 122 °F (0 °C to 50 °C). 14 °F to 122 °F (-10 °C to 50 °C) - Dry gases only.
LEAK INTEGRITY:	1 x 10 ⁻⁹ sml/sec of helium maximum, to the outside environment.
**MATERIALS IN FLUID CONTACT:	316 stainless steel, 416 stainless steel, Viton® O-rings. Optional O-rings: Buna®, EPR and Kalrez® .
ATTITUDE SENSITIVITY:	No greater than +15 degree rotation from horizontal to vertical; standard calibration is in horizontal position.
OUTPUT SIGNALS:	Linear 0-5 Vdc (2000 W min. load impedance); 4 - 20 mA optional (0 - 500 W loop resistance); maximum noise 20 mV peak to peak.
CONNECTIONS:	AFC26: 1/4" compression fittings. Optional: 6mm, 3/8" and 1/8" compression fittings or 1/4" VCR®. AFC36: 1/4" compression fittings. Optional: 6mm and 3/8" compression fittings or 1/4" VCR®. AFC 46: 3/8" compression fittings.
TRANSDUCER INPUT POWER:	AFC 26: +15 ±5% Vdc, 80 mA max, 1.2W; -15 ± 5% Vdc, 200 mA max, 3W; AFC 36 /AFC 46: +15 ±5% Vdc, 220 mA max, 3.3W; -15 ±5% Vdc, 600 mA max, 9W.
CIRCUIT PROTECTION:	Circuit boards have built-in polarity reversal protection. Replaceable fuses provide power input protection.

***The selection of materials of construction, is the responsibility of the customer. The company accepts no liability.*

Leak Integrity

1 x 10⁻⁹ smL/sec of helium max to outside environment.

Mass Flow Systems

Complete Mass Flow Systems include Command Modules, transducers and cables. Command modules contain appropriate power supplies, 24x2 alpha-numeric dot matrix display readout, and four panel buttons which provide complete control over all the various functions necessary to measure and/or control flow.

Optional built in Ethernet interface allows accessing any Internet-connected SDPROC from a browser on your work station, PC, or laptop computer.

TABLE 40 - FLOW RANGES FOR AFC

AFC 26	
CODE	UNITS [Nitrogen]
01	0 to 10 mL/min
02	0 to 20 mL/min
03	0 to 50 mL/min
04	0 to 100 mL/min
05	0 to 200 mL/min
06	0 to 500 mL/min
07	0 to 1 L/min
08	0 to 2 L/min
09	0 to 5 L/min
10	0 to 10 L/min
AFC 36	
11	0 to 15 L/min
30	0 to 20 L/min
31	0 to 30 L/min
32	0 to 40 L/min
33	0 to 50 L/min
AFC 46	
40	0 to 60 L/min
41	0 to 80 L/min
42	0 to 100 L/min

TABLE 41 - MAXIMUM PRESSURE DROP FOR AFC

FLOW RATE [liters/min]	AFC SERIES	
	[psid]	[bars]
up to 10	1.06	0.072
up to 15	3.87	0.26
up to 20	2.0	0.136
up to 30	3.5	0.238
up to 40	5.5	0.374
up to 50	8	0.544
up to 100	18.9	1.302

SDPROC and AFC Analog Mass Flow Controller



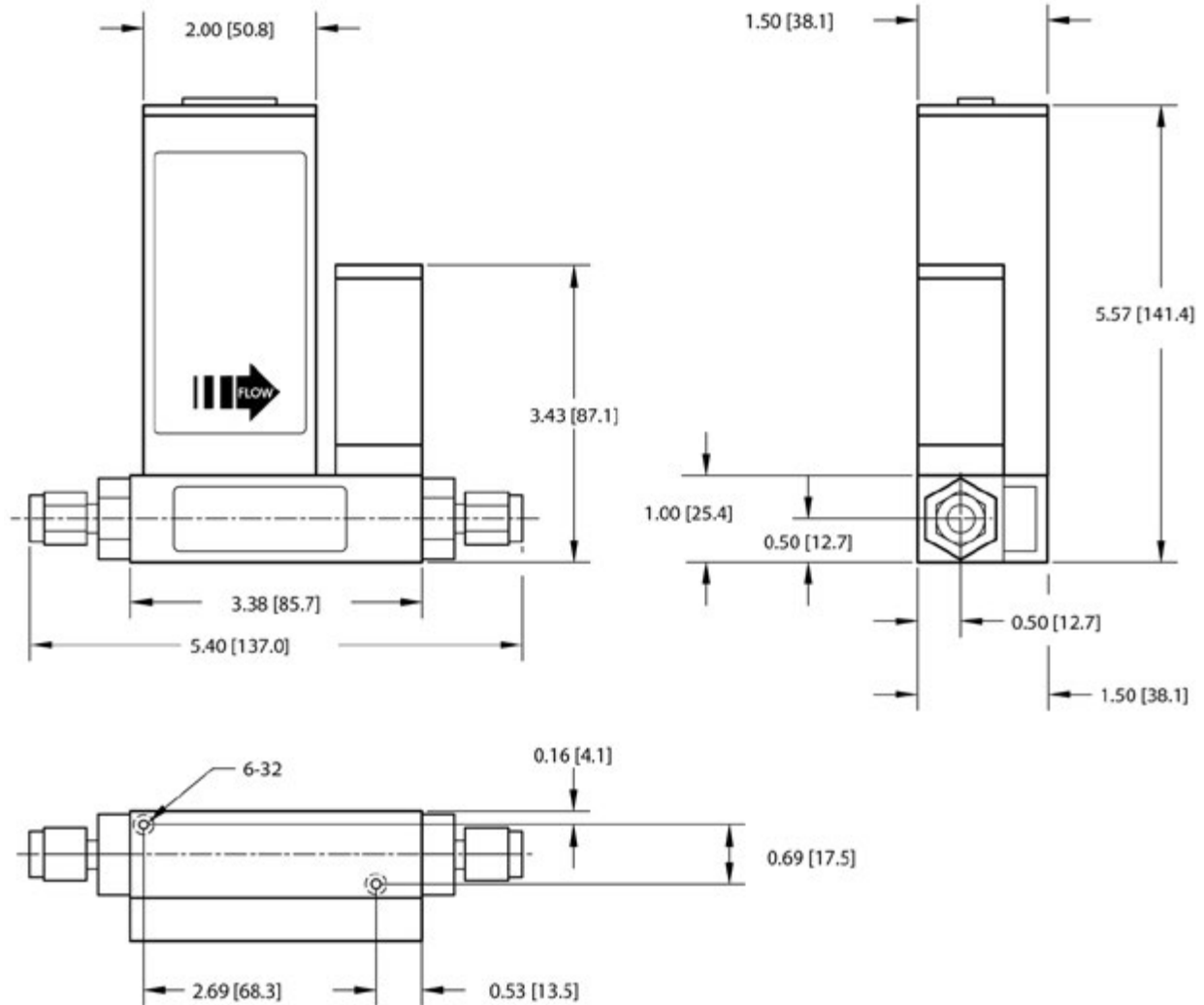

DIMENSIONS: INCH [mm]

AFC26
Analog Mass Flow Controller

NOTE: Aalborg® reserves the right to change designs and dimensions at its sole discretion at any time without notice. For certified dimensions please contact Aalborg®.

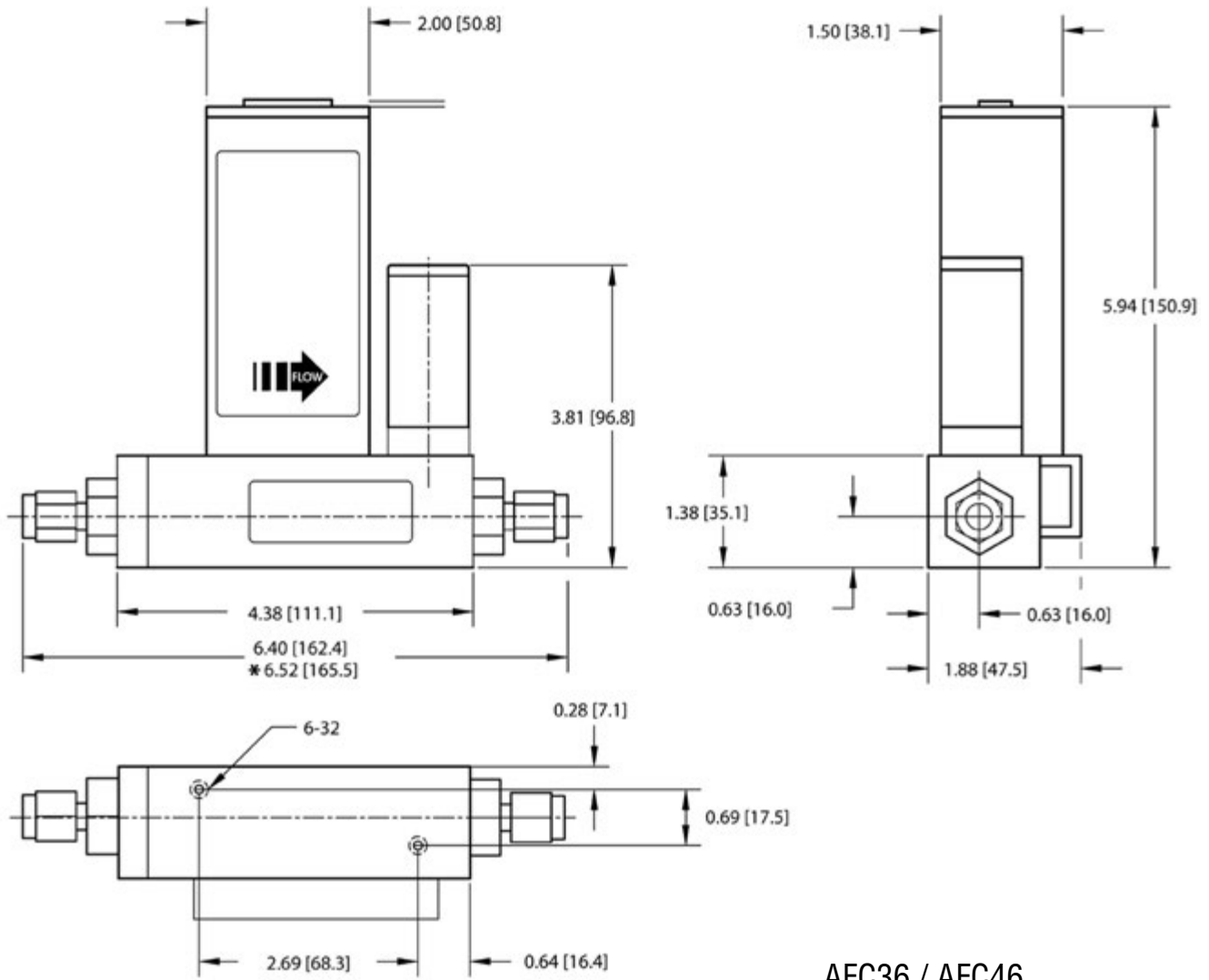

DIMENSIONS: INCH [mm] * FOR HIGH FLOW MASS FLOW CONTROLLER ONLY

AFC36 / AFC46
Mass Flow Controller

NOTE: Aalborg® reserves the right to change designs and dimensions at its sole discretion at any time without notice. For certified dimensions please contact Aalborg®.

Configure and Order Online: [AFC Mass Flow Controller](#)

AFC	MODEL
MAX FLOW (N ₂)	
26	10 L/min
36	50 L/min
46	100 L/min
MATERIAL	
S	Stainless Steel
SEALS	
V	Viton®
B	Buna®
E	EPR
T	PTFE / Kalrez®
FITTINGS	
A	1/4" Compression
B	1/8" Compression
C	1/4" VCR®
D	3/8" Compression
H	6mm Compression
MODEL	
AFC 26, 36	
AFC 26, 36	
AFC 26, 36	
AFC 26, 36, 46	
AFC 26, 36	
DISPLAY	
N	NO Display
POWER	
5	+15 Vdc
INPUT / OUTPUT SIGNAL	
C	0-5Vdc / 0-5Vdc
D	0-5Vdc / 4-20mA
DIGITAL INTERFACE	
0	NONE

AFC 36 S — V A N 5 — C 0

EXAMPLE: AFC36S-VAN5-A0 50 L/min [N₂] 20 psig

SPECIFY: Flow Range, Gas and Pressure *n.a. = not applicable

AFC36 stainless steel, Viton® seals with 1/4" compression fittings, without a display, ±15 Vdc, 0-5Vdc input/output signal, and no digital interface.