

OPERATING MANUAL

ZFM

Digital Mass Flow Meters

Download the latest version of
the manual from the product web page:
Aalborg.com/ZFM_o/83



AALBORG®

20 CORPORATE DRIVE • ORANGEBURG, NY 10962 • PHONE: 845.770.3000 • FAX: 845.770.3010
e-mail: info@aalborg.com • toll free in usa or canada: 1.800.866.3837 • web site: www.aalborg.com

Aalborg® is a registered trademark of Aalborg® Instruments & Controls.

NOTE: Aalborg® reserves the right to change designs and dimensions at its sole discretion at any time without notice. For certified dimensions please contact Aalborg®.

TABLE OF CONTENTS

1. UNPACKING THE ZFM MASS FLOW METER	1
1.1 Inspect Package for External Damage.....	1
1.2 Unpack the Mass Flow Meter.....	1
1.3 Returning Merchandise for Repair.....	1
2. INSTALLATION	1
2.1 Safety Instructions.....	1
2.2 Primary Gas Connections.....	2
3. ELECTRICAL CONNECTION	3
3.1 Power Supply Connections.....	5
3.2 Output Signals Connections.....	5
3.3 Digital Communication Interface Connections.....	6
4. PRINCIPLE OF OPERATION	8
5. SPECIFICATIONS	11
5.1 CE Compliance.....	11
6. OPERATING INSTRUCTIONS	13
6.1 Preparation and Warm Up.....	13
6.2 Swamping Condition.....	14
6.3 Meter Process Information (PI) screens.....	15
6.4 Local User Interface Menu Structure.....	17
6.4.1 Parameter Entry.....	17
6.4.2 Submenu "Change PP Password".....	18
6.4.3 Submenu "Device Information".....	19
6.4.4 Submenu "Engineering Units & K-Factors".....	19
6.4.5 "Submenu User-Defined Units".....	19
6.4.6 Submenu "K-Factors Settings".....	22
6.4.7 Submenu "Select Gas Table".....	23
6.4.8 Submenu "Flow Alarm Settings".....	24
6.4.9 Totalizers Totalizers Settings.....	26
6.4.10 Submenu "Pulse Output".....	28
6.4.11 General Settings.....	29
6.4.11.1 Display and Process Information (PI) Screens.....	29
6.4.11.2 Submenu "Communication Port Settings".....	31
6.4.11.3 Submenu "Modbus Interface" (optional feature).....	32
6.4.11.4 Relay Assignment.....	33
6.4.11.5 Analog Output configuration.....	34
6.4.11.6 Status LED Settings.....	36
6.4.11.7 Signal Conditioner Settings.....	37
6.4.12 Sensor Zero Calibration.....	37

6.4.13 Submenu "Alarms and Diagnostic".....	39
6.4.13.1 Alarm Event Register.....	39
6.4.13.2 Diagnostic Events Register.....	43
6.4.13.3 SAR ADC Analog Input Diagnostic (read only).....	45
6.4.13.4 Flow Sensor SD ADC Diagnostic (read only).....	46
6.4.13.5 Analog Output and PO Queue Diagnostic (read only).....	46
6.4.13.6 CPU Temperature and Sensor Temperature Compensation (STC) Algorithm Diagnostic (read only).....	47
6.5 Multi-Functional Push-button operation.....	48
7. MAINTENANCE.....	50
7.1 Introduction.....	50
7.2 Flow Path Cleaning.....	50
7.2.1 Restrictor Flow Element (RFE).....	51
7.2.2 ZFM 17 Models.....	51
7.2.3 ZFM 37/47 Models.....	52
8. CALIBRATION PROCEDURES.....	52
8.1 Flow Calibration.....	52
8.2 "User Gas Table" Calibration of ZFM Mass Flow Meters.....	53
8.2.1 Connections and Initial Warm Up.....	53
8.2.2 ZERO Check/Adjustment.....	53
8.2.3 User Gas Linearization Table Calibration /Adjustment.....	54
9. MAIN GAS TABLE RECONFIGURATION (RESCALING).....	57
10. RS-485/RS-232 SOFTWARE INTERFACE COMMANDS.....	60
10.1 General.....	60
10.2 Commands Structure.....	61
10.3 ASCII Commands Set.....	63
11. TROUBLESHOOTING.....	79
11.1 Common Conditions.....	79
11.2 Troubleshooting Guide.....	80
11.3 Technical Assistance.....	82
12. CALIBRATION CONVERSIONS FROM REFERENCE GASES.....	82
APPENDIX I INTERNAL USER SELECTABLE GAS FACTOR TABLE (INTERNAL "K" FACTORS).....	83
APPENDIX II GAS FACTOR TABLE ("K" FACTORS).....	84
APPENDIX III COMPONENT DIAGRAM.....	88
APPENDIX IV DIMENSIONAL DRAWINGS.....	90
APPENDIX V WARRANTY.....	91

1. UNPACKING THE ZFM MASS FLOW METER

1.1 Inspect Package for External Damage

Your ZFM Mass Flow Meter was carefully packed in a sturdy cardboard carton, with anti-static cushioning materials to withstand shipping shock. Upon receipt, inspect the package for possible external damage. In case of external damage to the package contact the shipping company immediately.

1.2 Unpack the Mass Flow Meter

Open the carton carefully from the top and inspect for any sign of concealed shipping damage. In addition to contacting the shipping carrier please forward a copy of any damage report to your distributor or Aalborg® directly.

When unpacking the instrument please make sure that you have all the items indicated on the Packing List. Please report any shortages promptly.

1.3 Returning Merchandise for Repair

Please contact the customer service representative of your distributor or Aalborg® if you purchased your Mass Flow Meter directly, and request a **Return Authorization Number (RAN)**. **Equipment returned without an RAN will not be accepted.** Aalborg® reserves the right to charge a fee to the customer for equipment returned under warranty claims if the instruments are tested to be free from warrantied defects.

Shipping charges are borne by the customer. Meters returned “collect” will not be accepted!

It is mandatory that any equipment returned for servicing be purged and neutralized of any dangerous contents including but not limited to toxic, bacterially infectious, corrosive or radioactive substances. No work shall be performed on a returned product unless the customer submits a fully executed, signed SAFETY CERTIFICATE. Please request form from the Service Manager.

2. INSTALLATION

2.1 Safety Instructions



Aalborg® warranties and all other responsibilities by direct or implied are voided if users fail to follow all instructions and procedures described in this manual.



LIFE SUPPORT APPLICATIONS: The ZFM is not designed for use in life support applications where malfunctioning of the device may cause personal injury. Customers using or selling this device for use in such applications do so at their own risk and agree to be fully responsible for any damages resulting from improper use or sale.



Some of the IC devices used in the ZFM are static-sensitive and may be damaged by improper handling. When adjusting or servicing the device, use of a grounded wrist strap is recommended to prevent inadvertent damage to the integral solid-state circuitry.

2.2 Primary Gas Connections

Please note that the ZFM Mass Flow Meter will not operate with liquids. Only clean gases are allowed to be introduced into the instrument. If gases are contaminated they must be filtered to prevent the introduction of impediments into the sensor.



CAUTION: ZFM TRANSDUCERS SHOULD NOT BE USED FOR MONITORING OXYGEN GAS UNLESS SPECIFICALLY CLEANED AND PREPARED FOR SUCH APPLICATION.

For more information, contact your distributor or Aalborg®.

Attitude limit of the Mass Flow Meter is $\pm 15^\circ$ from calibration position (standard calibration is in horizontal position). This means that the gas flow path of the Flow Meter must be within this limit in order to maintain the original calibration accuracy. Should there be need for a different orientation of the meter, zero adjustment or re-calibration may be necessary. It is also preferable to install the ZFM transducer in a stable environment, free of frequent and sudden temperature changes, high moisture, and drafts.

Prior to connecting gas lines inspect all parts of the piping system including ferrules and fittings for dust or other contaminant's.

When connecting the gas system to be monitored, be sure to observe the direction of gas flow as indicated by the arrow on the front of the meter.

Insert tubing into the compression fittings until the ends of the properly sized tubing home flush against the shoulders of the fittings. Compression fittings are to be tightened to one and one quarter turns according to the manufacturer's instructions. Avoid overtightening which may seriously damage the compression fitting!



CAUTION: For ZFM 17/37/47/57/67/77 models, the maximum pressure in the gas line should not exceed 500 PSIA (34.47 bars). Applying pressure above 500 PSIA (34.47 bars) will seriously damage the flow sensor.



The user shall install the instrument only in process lines that meet the ZFM meter's pressure and temperature ratings. A margin of safety should be provided if spikes and surges exist in the process. Proper pressure relief valves and burst plates should be installed in high pressure applications.



To avoid obstructions and contamination in the sensor tube and the narrow flow channels in the laminar flow element, the user should install the instrument in process lines that have clean gases. Upstream particulate filters are recommended for all applications.

ZFM transducers are supplied with either standard 1/4 inch (ZFM 17 and 37), 3/8 inch (ZFM 47/57), 1/2 inch (ZFM 67), or optional 1/8 inch inlet and outlet compression fittings which should NOT be removed unless the meter is being cleaned or calibrated for a new flow range. ZFM 77 transducers are supplied with 3/4 inch FNPT fittings.

3. ELECTRICAL CONNECTION

ZFM is equipped with a miniature 9 pins male "D-sub" power and analog/relay output interface connector. Pin diagram is presented in **Figure 3-1**.

PIN	FUNCTION	NOTE
1	Reserved, do not use	Factory use only!
2	Analog (0-5Vdc, 0-10Vdc or 4-20 mA) Output (+)	Output. Do not apply external voltage or current source! Observe recommended load impedance!
3	Analog (0-5Vdc, 0-10Vdc) Output reference (-)	Common (return) for pin 2 when (0-5Vdc or 0-10 Vdc interface is selected as active
4	Power supply, positive (+)	Power input 14 – 26 Vdc
5	Power supply, common (-)	Power input
6	Analog (4-20mA) Output reference (-)	Common (return) for pin 2 when 4-20 mA interface is selected as active
7	Reserved, do not use	Factory use only!
8	Solid State SPST Relay NO (normally open) contact #1	Do not exceed SSR maximum voltage 48 AC peak/DC and maximum load current 400 mA
9	Solid State SPST Relay NO (normally open) contact #2	

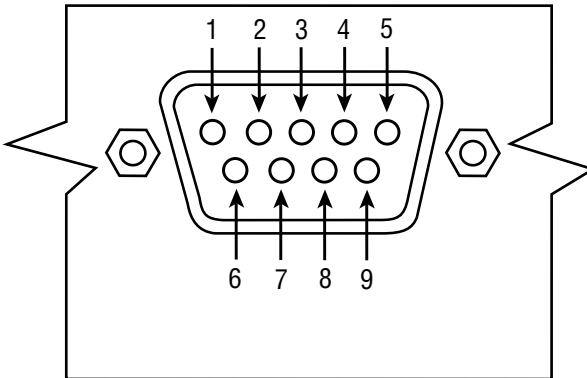

Figure 3.1 - ZFM 9 PIN "D" CONNECTOR CONFIGURATION



IMPORTANT NOTE: Generally, "D" Connector numbering patterns are standardized. There are, however, some connectors with nonconforming patterns and the numbering sequence on your mating connector may or may not coincide with the numbering sequence shown in our pin configuration table above. It is imperative that you match the appropriate wires in accordance with the correct sequence regardless of the particular numbers displayed on the mating connector.

3.1 Power Supply Connections

The power supply requirements for ZFM transducers are: 14 to 26 Vdc, with maximum load current at least 200 mA (unipolar power supply). Maximum ripple below 150 mV P-P.

DC Power (+) ----- pin 4 of the 9 pin "D" connector

DC Power (-) ----- pin 5 of the 9 pin "D" connector



CAUTION: Do not apply power voltage above 26Vdc. Doing so will cause ZFM damage or faulty operation.



Make sure power is OFF when connecting or disconnecting any cables or wires in the system.



NOTE: The (+) and (-) power inputs are each protected by a 300mA M (medium time-lag) resettable fuse. If a shorting condition or polarity reversal occurs, the fuse will cut power to the flow transducer circuit. Disconnect the power to the unit, remove the faulty condition, and reconnect the power. The fuse will reset once the faulty condition has been removed.

3.2 Output Signals Connections



CAUTION: When connecting the load to the output terminals, do not exceed the rated values shown in the specifications. Failure to do so might cause damage to this device. Be sure to check if the wiring and the polarity of the power supply is correct before turning the power ON. Wiring error may cause damage or faulty operation.

ZFM series Mass Flow Meters are equipped with calibrated 0-5Vdc, 0-10Vdc or 4-20 mA output signals. This linear output signal represents 0-100% of the flow meter's full scale range. User may select desired analog interface type using local OLED/Joystick interface or via digital communication interface.



CAUTION: The 4-20 mA current loop output is self-powered (sourcing non-isolated type). Do NOT connect an external voltage source to the output signals.

For 0-5 VDC or 0-10 VDC output signal connection:

External load Plus (+) ----- pin 2 of the 9 pin "D" connector

External load Minus (-) ----- pin 3 of the 9 pin "D" connector



CAUTION: When connecting the load to the output terminals always check actual analog output interface configuration. Connecting low impedance (< 5KOhm) loads to the 0-5Vdc or 0-10 Vdc output may cause damage or faulty operation of the electronics circuitry.

For 4-20 mA output signal connection:

External load Plus (+) ----- pin 2 of the 9 pin "D" connector

External load Minus (-)----- pin 6 of the 9 pin "D" connector



CAUTION: When connecting the load to the output terminals always check actual analog output interface configuration. Connecting high impedance (> 500 Ohm) loads to the 4-20 mA output may cause non linear or faulty operation of the electronics circuitry

To eliminate the possibility of noise interference, it is recommended use a separate cable entry for the DC power and analog output interface signal lines.

3.3 Digital Communication Interface Connections

The digital interface operates via RS232 (optional RS485) and provides access to all applicable internal configuration parameters and data.



CAUTION: Before proceeding with communication interface connection verify meter actual communication interface type. For devices with OLED display the interface type will be briefly (about 2 seconds) displayed on the banner screen when power is applied. If you meter does not have display the communication interface type can be identified from meter model number.

Communication Settings for RS232/RS485 communication interface:

Baud rate: default 9600 baud (user-selectable. See specification section).

Stop bit: 1

Data bits: 8

Parity: None

Flow Control: None

RS232 Communication Interface Connection:

Crossover connection must be established:

HOST PC RS232 RX ZFM (RS232 TX)
(pin 2 on the host PC DB9 connector)-----pin 3 (Ring)of the 3 pin stereo jack connector (TX-)

HOST PC RS232 TX ZFM (RS232 RX)
(pin 3 on the host PC DB9 connector)----- pin 2 (Tip) of the 3 pin stereo jack connector (RX+)

HOST PC RS232 SIGNAL GND ZFM (Digital GND)
(pin 5 on the host PC DB9 connector)-----pin 1 (Sleeve) of the 3 pin stereo jack connector

Each ZFM equipped with RS232 interface option supplied with default crossover 6 feet long communication cable (AALBORG P/N: CBL-A232) DB9 Female to Stereo 3.5 mm Plug.

If custom length cable is required it can be assembled using connection diagram shown on **Figure 3.2**

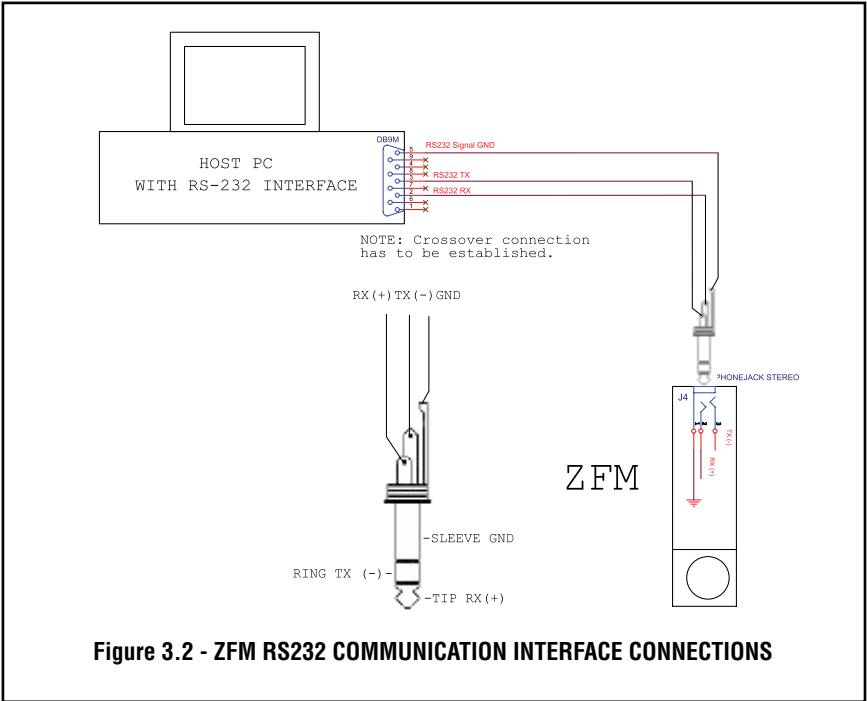

Figure 3.2 - ZFM RS232 COMMUNICATION INTERFACE CONNECTIONS

Optional RS485 Communication Interface Connection:

The RS485 converter/adapter must be configured for: multidrop, 2 wire, half duplex mode (See **Figure 3.3**). The transmitter circuit must be enabled by TD or RTS (depending on which is available on the converter/adapter). Settings for the receiver circuit should follow the selection made for the transmitter circuit in order to eliminate echo.

- RS485 A line T(-) or R(-) pin 3 on 3 pins Audio-connector, middle section or "ring" ZFM (TX-), (WHITE wire)
- RS485 B line T(+) or R(+) pin 2 on 3 pins Audio-connector, the "tip" section ZFM (RX+), (RED wire)
- RS485 GND (if available) pin 1 on 3 pins Audio-connector, the "sleeve" section ZFM (GND) (Shield wire)

Each ZFM equipped with RS485 interface option supplied with default 3 feet long communication cable (AALBORG P/N: CBL-A485) Stereo 3.5 mm Plug. to stripped wires.

If custom length cable is required it can be assembled using connection diagram shown on **Figure 3.3**.

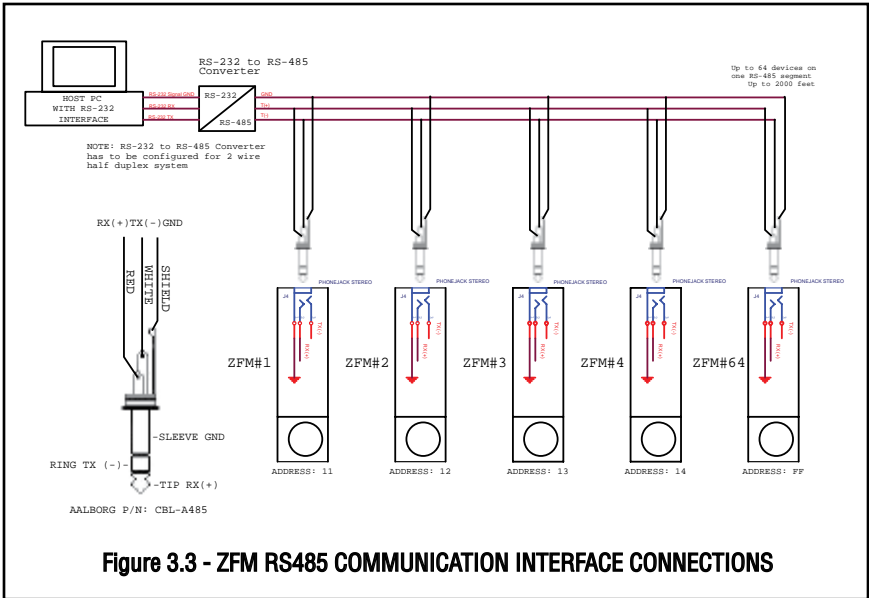

Figure 3.3 - ZFM RS485 COMMUNICATION INTERFACE CONNECTIONS

When the ZFM device is set as the last device on the long RS485 bus segment the 220 Ohm bus termination resistor must be connected between ZFM RS485 (+) and (-) terminals close to this device (<6 feet).

4. PRINCIPLE OF OPERATION

The stream of gas entering the Mass Flow transducer is split by shunting a small portion of the flow through a capillary stainless steel sensor tube. The remainder of the gas flows through Restrictor Flow Element (RFE) in the primary flow conduit. The geometry of the RFE in the primary conduit and the sensor tube are designed to ensure laminar flow in each branch. According to principles of fluid dynamics the flow rates of a gas in the two laminar flow conduits are proportional to one another. Therefore, the flow rates measured in the sensor tube are directly proportional to the total flow through the transducer.

In order to sense the flow in the sensor tube, heat flux is introduced at central section of the sensor tube by means of precision wound heater-sensor coil. Heat is transferred through the thin wall of the sensor tube to the gas flowing inside. The sensor tube measures its mass flow rate by means of two identical RTD coil windings (an upstream winding and a downstream winding) located symmetrically from the center of the sensor. As gas flow takes place heat is carried by the gas stream from the upstream coil to the downstream coil windings. This causes the temperature of the downstream winding to become higher than the temperature of the upstream winding. As a result, the electrical resistance of the downstream winding becomes higher than the resistance of the upstream winding. The difference in these two resistances is the output signal of the instrument and is directly proportional to the mass flow rate of the gas flowing through the sensor tube.

ZFM flow meter supports multi-gas/multi-range functionality which allow users on site rescaling the instruments to the desired gas and full scale range based on minimum and maximum supported full scale ranges (see table below) for given model number (currently following gases are supported: N2, Air, O2, Argon, Helium, CO2).

Table 4.1 - ZFM models and supported Full Scale Flow Ranges

FLOW RANGES FOR ZFM		
ZFM LOW FLOW MASS METERS		
CODE	Nominal Flow Range sL/min [N2]	Reconfigurable Full Scale Flow Ranges [Min-Max] sL/min (N2)
00	0.0125	0.003125-0.0125
01	0.05	0.0125-0.05
02	0.2	0.05-0.2
03	0.8	0.2-0.8
04	2.0	0.5-2.0
05	6.0	1.5-6.0
06	10.0	2.5-10.0

ZFM is using “**Primary Calibration Table**” which was calibrated on the factory with Nitrogen and proprietary empiric K-Factors curves (individually developed by each model) to transfer calibration curve to the “**Main Gas Table**” according to desired full scale range and gas. Main Gas Calibration Table [MO] usually configured on the factory for flowing fluid and full scale range according to customer order. It can be reconfigured by user to desired flow range and supported gas using free and easy-to-use "ZFM Configuration Utility" software (Tools/Main Gas Table Rescaling procedure).

ZFM model Mass Flow Meter incorporates a powerful on-board 32 bits microprocessor and non-volatile memory that stores all hardware specific variables, Primary calibration table and up to 10 different user calibration tables. The flow rate can be displayed in 45 different volumetric or mass flow engineering units. Flow meter parameters and functions can be programmed locally via optional OLED/Joystick interface or remotely via the RS232/RS485 interface or optional Modbus RTU interface. ZFM flow meters support various functions including: two programmable flow totalizers, low, high or range flow alarm, automatic zero adjustment (activated via local or communication interface), programmable SSR relay, programmable 0-5 Vdc, 0-10 Vdc or 4-20 mA analog outputs, user-programmable pulse output (via SSR), self diagnostic alarm, 26 internal and user defined K-factor. Optional local OLED readout with adjustable brightness level provides flow rate and total volume reading in currently selected engineering units and diagnostic events indication.

5. SPECIFICATIONS

FLOW MEDIUM: Please note that ZFM Mass Flow Meters are designed to work only with clean gases. Never try to measure flow rates of liquids with any ZFM.

CALIBRATIONS: Performed at standard conditions [14.7 psia (101.4 kPa) and 70 °F (21.1 °C)] unless otherwise requested or stated.

ENVIRONMENTAL (PER IEC 664): Installation Level II; Pollution Degree II.

FLOW ACCURACY (INCLUDING LINEARITY): $\pm(0.5\% \text{ RD} + 0.2\% \text{ FS})$ at calibration temperature and pressure.

REPEATABILITY: $\pm 0.15\%$ of full scale.

FLOW TEMPERATURE COEFFICIENT: 0.05% of full scale/ °C or better.

FLOW PRESSURE COEFFICIENT: 0.01% of full scale/psi (6.895 kPa) or better.

FLOW RESPONSE TIME: 1000ms time constant; approximately 2 seconds to within $\pm 2\%$ of set flow rate for 0% to 100% of full scale flow.

MAXIMUM GAS PRESSURE: 1000 PSIG (6894 kPa gauge).

MAXIMUM PRESSURE DROP: 0.8 PSID (at 10 L/min flow). 8 psi (at 100 L/min flow). See Table 5.4 for pressure drops associated with various models and flow rates.

GAS AND AMBIENT TEMPERATURE: 32 °F to 122 °F (0 °C to 50 °C). 14 °F to 122 °F

RELATIVE GAS HUMIDITY: Up to 70%.

LEAK INTEGRITY: 1×10^{-9} sccs He maximum to the outside environment.

ATTITUDE SENSITIVITY: Incremental deviation of up to 0.5% from stated accuracy, after re-zeroing.

OUTPUT SIGNALS: Linear 0-5 Vdc (3000 ohms min. load impedance);
Linear 0-10 Vdc (5000 ohms min. load impedance);
Linear 4-20 mA (550 ohms maximum loop resistance).
Maximum noise 10mV peak to peak (for 0-5/0-10 Vdc output).

TRANSDUCER INPUT POWER: 14 to 26 Vdc, 150 mV maximum peak to peak output noise. Power consumption: +12Vdc (200 mA maximum); +24Vdc (160 mA maximum); Circuit board have built-in polarity reversal protection, 300mA resettable fuse provide power input protection.

WETTED MATERIALS: Anodized aluminum, brass, 316 stainless steel, 416 stainless steel, VITON® O-rings; BUNA-N®, NEOPRENE® or KALREZ® O-rings are optional.



CAUTION: Aalborg® makes no expressed or implied guarantees of corrosion resistance of mass flow meters as pertains to different flow media reacting with components of meters. It is the customers' sole responsibility to select the model suitable for a particular gas based on the fluid contacting (wetted) materials offered in the different models.

INLET AND OUTLET CONNECTIONS:

Model ZFM 17/37 standard 1/4" compression fittings,
Model ZFM 47/57 standard 3/8" compression fittings,
Model ZFM 67 standard 1/2" compression fittings,
Model ZFM 77 standard 3/4" FNPT fittings,

Optional 1/8" or 3/8" compression fittings and 1/4" VCR fittings are available.

DISPLAY: Optional 128x64 graphic yellow OLED with **Esc** button and Joystick interface.

CALIBRATION OPTIONS: Standard is one 10 points NIST calibration. Optional, up to 9 additional calibrations may be ordered at additional charge.

5.1 CE Compliance

EMC Compliance with 2004/108/EC as amended. CISPR11

Emission Standard: EN61000-6-3, Group 1, Class A

Immunity Standard: EN61000-6-1, IEC EN 61000-4-2, IEC EN 61000-4-3

FLOW RANGES

TABLE 5.1 ZFM 17 LOW FLOW MASS FLOW METER*

CODE	Reconfigurable Full Scale Ranges, sL/min [N ₂] [Min - Max]	Nominal Flow Ranges sL/min [N ₂]
00	0.003125 to 0.0125	0.0125
01	0.125 to 0.05	0.05
02	0.05 to 0.2	0.2
03	0.2 to 0.8	0.8
04	0.5 to 2.0	2.0
05	1.5 to 6.0	6.0
06	2.5 to 10.0	10.0

TABLE 5.2 ZFM 37 MEDIUM FLOW MASS FLOW METER*

CODE	Reconfigurable Full Scale Ranges, sL/min [N ₂] [Min - Max]	Nominal Flow Ranges sL/min [N ₂]
30	10 to 30	30
31	20 to 50	50

TABLE 5.3 ZFM 47/57/67/77 HIGH FLOW MASS FLOW METERS*

CODE	Reconfigurable Full Scale Ranges, sL/min [N ₂] [Min - Max]	Nominal Flow Ranges sL/min [N ₂]
40	30 to 100	100

*Flow rates are stated for Nitrogen at STP conditions [i.e. 70 °F (21.1 °C) at 1 atm]. For other gases use the K factor as a multiplier from APPENDIX 2.

TABLE 5.4 PRESSURE DROPS

MODEL	FLOW RATE [std liters/min]	MAXIMUM PRESSURE DROP		
		[mm H2O]	[psid]	[kPa]
ZFM 17	up to 10	130	0.18	1.275
ZFM 47	20	TBD	TBD	TBD
	30	TBD	TBD	TBD
	40	TBD	TBD	TBD
	50	TBD	TBD	TBD
ZFM 47	60	TBD	TBD	TBD
	100	TBD	TBD	TBD
ZFM 57	200	TBD	TBD	TBD
ZFM 67	500	TBD	TBD	TBD
ZFM 77	1000	TBD	TBD	TBD

TABLE 5.5 APPROXIMATE WEIGHTS

MODEL	WEIGHT	SHIPPING WEIGHT
ZFM17A flow meter	0.85 lbs. (0.4 kg)	2.55 lbs. (1.2 kg)
ZFM37/47A flow meter	TBD	TBD
ZFM57A flow meter	TBD	TBD
ZFM67A flow meter	TBD	TBD
ZFM77A flow meter	TBD	TBD

6. OPERATING INSTRUCTIONS

6.1 Preparation and Warm Up

It is assumed that the Mass Flow Meter has been correctly installed and thoroughly leak tested as described in section 2. Make sure the flow source is OFF. Initially, after the power is first turned on, the Banner Screen is shown for 2 seconds, then device firmware and EEPROM data base table revisions on the first line, communication interface type and hexadecimal address value on the second line, Communication Port baud rate on the third line and Modbus h/w status and decimal address value on the fourth line are shown for another 2 seconds. Subsequently, the actual process information (PI) is displayed.

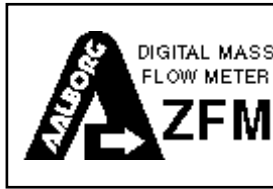

Figure 6.1: ZFM first Banner Screen

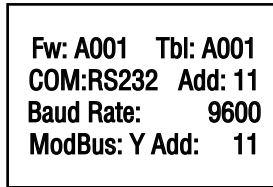

Figure 6.2: ZFM Firmware and Communication Interface Info Screen

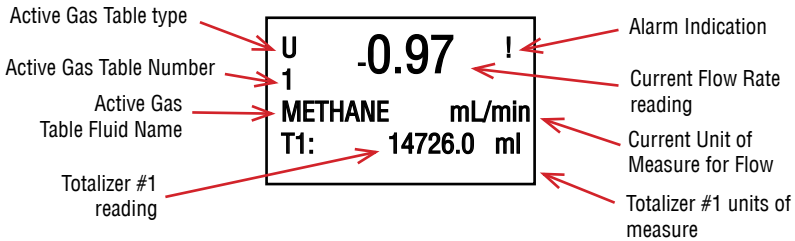

Figure 6.3: ZFM Initial Process Information (PI) Screen



NOTE: Actual content of the OLED screen may vary depending on the model and device configuration.



NOTE: Allow the ZFM Flow Meter to warm-up for a MINIMUM of 3 minutes.

During initial powering of the ZFM flow meter, the flow output signal will be indicating a higher than usual output. This is an indication that the ZFM flow meter has not yet attained its minimum operating temperature. This condition will automatically cancel within a few minutes and the transducer should eventually indicate zero.



NOTE: During the first 3 minutes of the initial powering of the ZFM flow meter, the status LED will emit CONSTANT UMBER light.

For the ZFM flow meter with optional OLED display: If the "Power Up Even" diagnostic is activated, the alarm indication "!" will display in the left upper corner of the OLED screen until the end of the warm up period.



NOTE: After 3 minutes of the initial powering of the ZFM flow meter, the status LED will emit a constant GREEN light (normal operation, ready to measure).



NOTE: For flow rate measurement with specified accuracy allow at least 30 minutes warming up and stabilizing. During warm-up period, fluid pressure may either be on or off.

6.2 Swamping Condition

If a flow of more than 10% above the nominal maximum flow rate of the Mass Flow Meter is taking place, a condition known as "swamping" may occur. Readings of a "swamped" meter cannot be assumed to be either accurate or linear. Flow must be restored to below 110% of maximum meter range. Once flow rates are lowered to within calibrated range, the swamping condition will end. Operation of the meter above 110% of nominal maximum calibrated flow rate may increase recovery time.

6.3 Meter Process Information (PI) screens

Based on meter configuration, different parameters may be displayed in the Process Information (PI) screen by moving control joystick **UP** or **DN**. Process Information screens can be configured to be static or dynamic (see Paragraph 6.4.11.1 "Display and Process Information (PI) Screens"). Using PI Screen Mask settings user can enable (unmask) or disable (mask) up to 6 different process information combinations (see **Figure 6.4**). In the Static Mode moving joystick **UP** pages through the PI screens in the forward direction, moving joystick **DN** pages through the PI screens in the reverse direction. When the last PI screen is reached, the firmware "wraps around" and scrolls to the initial PI screen once again.

In the Dynamic Display Mode, firmware initiates automatic screen sequencing with user adjustable screen Cycle Time (see Paragraph 6.4.11.1 "Display and Process Information (PI) Screens"). When the last PI screen is reached, the firmware "wraps around" and scrolls to the initial PI screen once again.

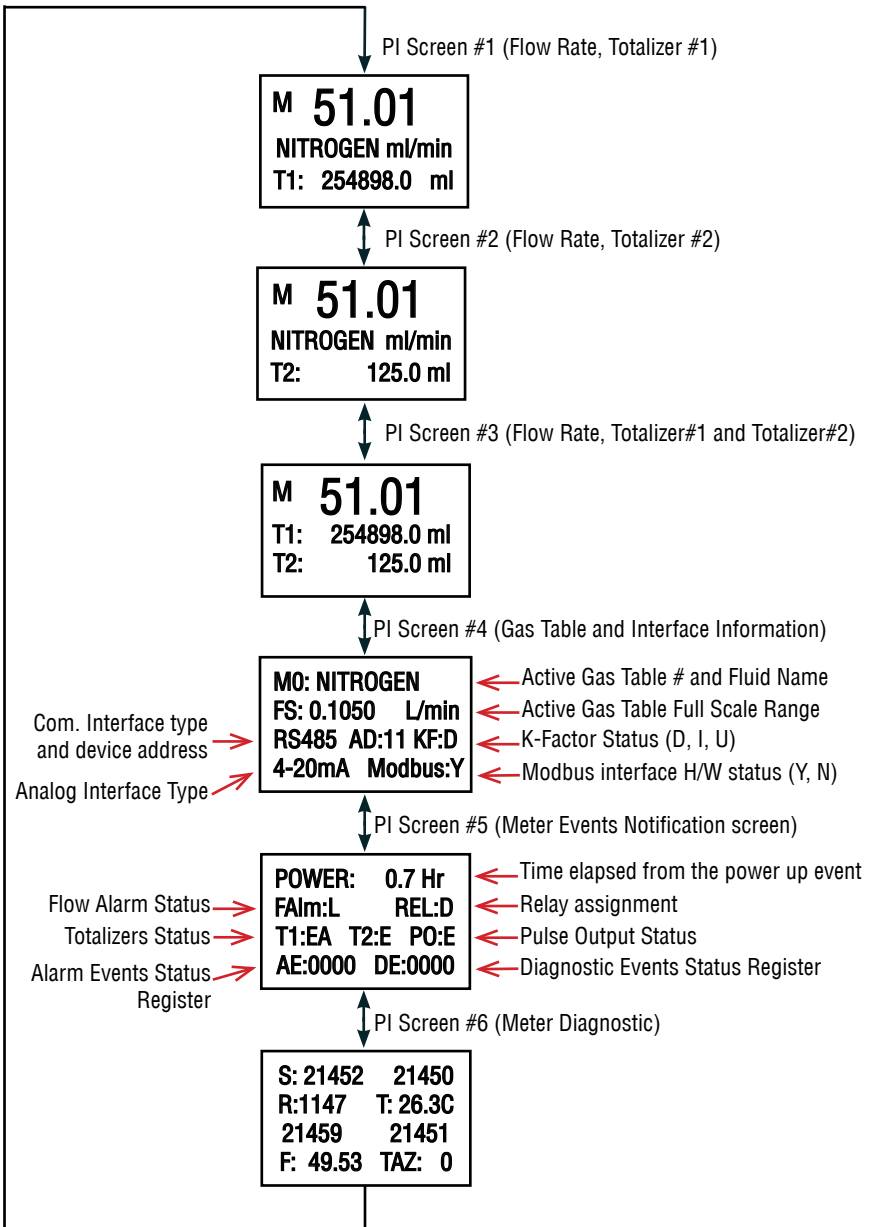

Figure 6.4: ZFM Process Information (PI) Screens

6.4 Local User Interface Menu Structure

The diagram on the **Figure 6.9** gives a general overview of the standard top-level display menu structure (when running firmware version A001). The ESC push-button is used to toggle between the Process Mode (PI screens) and the Setup menus and return to upper menu level.

In order to move through the menu items user must move Joystick **UP** and **DN**. When the last item in the menu is reached, the menu “wraps around” and scrolls back to the beginning of the menu items list. Similarly, when the first menu item is highlighted and the Joystick is moved **UP**, the menu “wraps around” and scrolls down to the end of the menu item’s list. In order to select desired menu item user must press Joystick down (this action is equivalent to the **Enter** button). To go back to upper menu level user must press **Esc** button.

All process configuration parameter’s settings are password-protected. In order to access or change them, Program Protection should be disabled. Each time the device is powered up, the Program Protection is enabled automatically. By default, the device is shipped from the factory with the Program Protection (PP) password set to Zero (PP Disabled). If PP password is set to Zero (Disabled), entering a PP password is not required. A subsequent screen will appear and the Program Protection menu item will be selected:

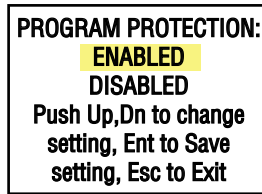

Figure 6.5

Moving Joystick **DN** to select the Disabled option and then pushing Joystick (**ENT**) to save settings will disable program protection.

If PP password is set to any value more than Zero, the firmware will prompt with “**Enter PP Password**” (see **Figure 6.6**). User must enter up to 3 digits program protection code, in order to be able to access password protected menus. Once the correct password is entered, Program Protection is turned off until the unit is powered up again.

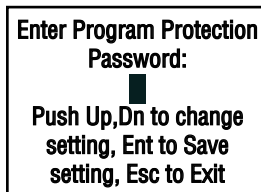

Figure 6.6

6.4.1 Parameter Entry

There are two methods of data entry:

- Direct numerical number entry.
- Tabular Input from a table menu.

If the menu with direct numerical entry is selected move Joystick **UP** or **DN** button to increment / decrement digit value from 0-9. Move Joystick **RIGHT** or **LEFT** to move the cursor to another digit position. When the desired value is entered, use ENT button to accept (save in the EEPROM) the new value.



NOTE: During data entry the input values are checked for acceptability. If data is not acceptable, it is rejected and a message is generated indicating that the new data has not been accepted.

If the menu with tabular entry is selected, the available menu options can be set using Joystick **UP** and **DN** buttons and are accepted by pressing the ENT button.

6.4.2 Submenu “Change PP Password”

In order to get access to “Change PP Password” menu, Program Protection must be disabled. If PP password is set to Zero (Disabled), entering PP Password is not required and PP can be disabled from “Program Protection” menu (see **Figure 6.5**). If PP Password is set to any value more than Zero, the firmware will prompt with “**Enter PP Password**” (see **Figure 6.6**). User must enter program protection code (up to 3 digits). If PP password is lost or forgotten, contact the factory or your distributor.

Once “Change PP Password” menu is selected, the following screen will appear:

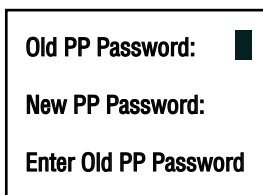

Figure 6.7

In order to protect device configuration parameters when changing the PP password, the old PP password must be entered.



NOTE: By default the device is shipped from the factory with Program Protection (PP) password set to Zero (PP Disabled).

Once old and new passwords are entered the firmware will prompt with a confirmation message (see **Figure 6.8**) that the new password has been saved.

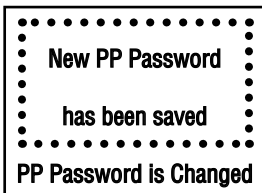

Figure 6.8

6.4.3 Submenu “Device Information”

This submenu contains information about the device’s main configuration parameters. These items are informational only, not password-protected, and can’t be changed (read only).

6.4.4 Submenu “Engineering Units & K-Factors”

Use the “Engineering Units and K-Factor Menu” to navigate to “Measuring Units” menu option. This option allows configuration of the flow meter with the desired units of measurement. These are global settings and determine what appears on all process information screens and data log records. Units should be selected to meet your particular metering needs. A total of 47 different volumetric and mass-based engineering units are supported (See Table 6.1).



NOTE: Program the Measuring Units first because subsequent menus may be based on the units selected. Once Flow Unit of Measure is changed the Totalizer’s Unit of Measure will be automatically changed.

6.4.5 “Submenu User-Defined Units”

In addition to conventional flow units user-defined flow engineering units may be selected. Use the “Engineering Units and K-Factor Menu” to navigate to the “User-defined Units” menu option. This option enables user-defined configuration of any engineering unit required for process measurement.

The following three parameters are available for this function:

- a) UD Unit volume K-Factor (defined in Liters),
- b) UD Unit time base (defined in Seconds),
- c) UD Unit use density (units with or without density support).

Before using the User-defined Unit, be sure the proper conversion factor of the new unit with respect to one liter is set (the default entry is 1.00 Liter). Also, proper time base values for User-Defined Units must be set.

Figure 6.9 ZFM Upper Levels Menu Structure

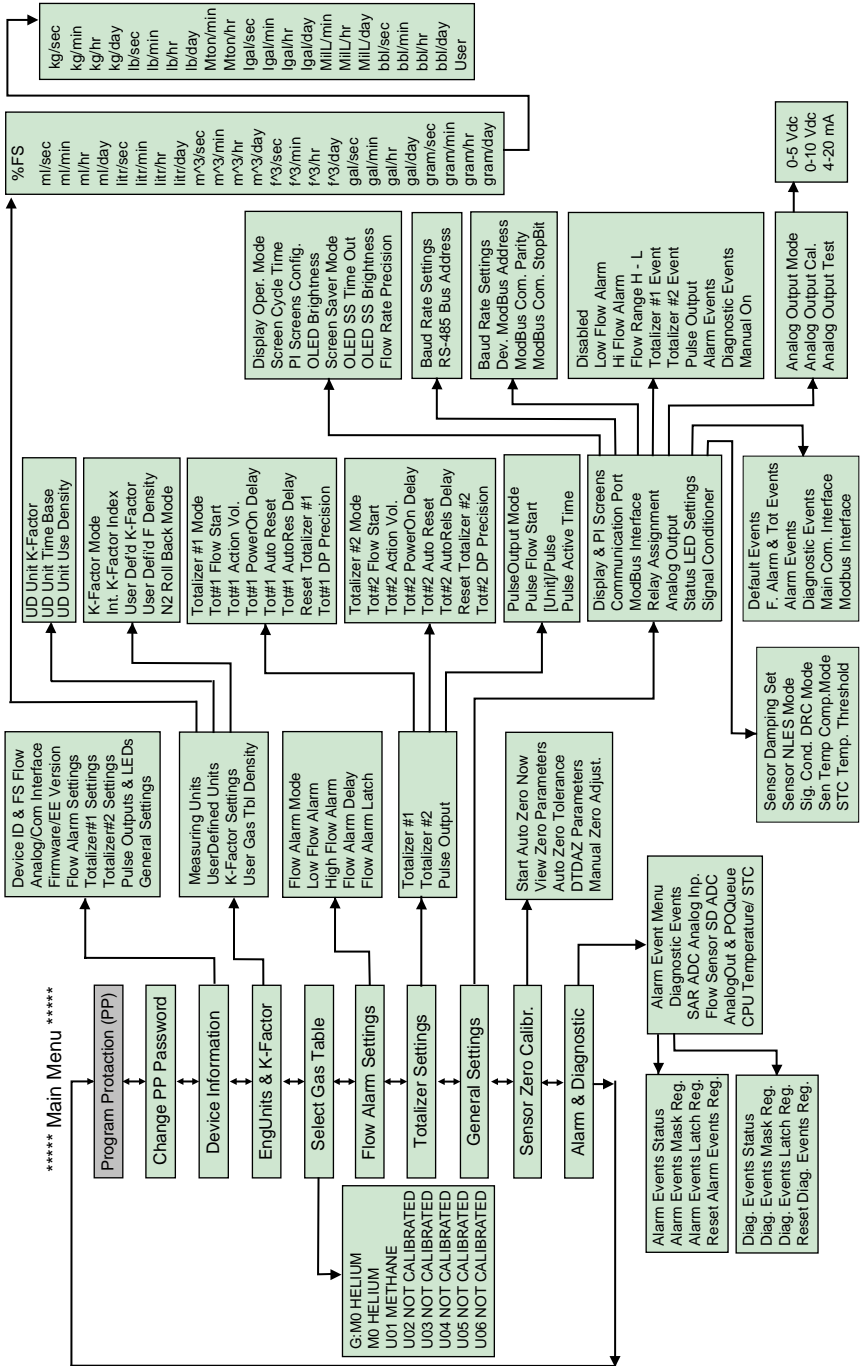

TABLE 6.1 SUPPORTED ENGINEERING UNITS LIST

NUMBER	FLOW RATE ENGINEERING UNITS	TOTALIZER ENGINEERING UNIT	DESCRIPTION
1	%FS	%s	Percent of full scale
2	mL/sec	mL	Milliliter per second
3	mL/min	mL	Milliliter per minute
4	mL/hr	mL	Milliliter per hour
5	mL/day	mL	Milliliter per day
6	L/sec	L	Liter per second
7	L/ min	L	Liter per minute
8	L/hr	L	Liter per hour
9	L/day	L	Liter per day
10	m ³ /sec	m ³	Cubic meter per second
11	m ³ / min	m ³	Cubic meter per minute
12	m ³ /hr	m ³	Cubic meter per hour
13	m ³ /day	m ³	Cubic meter per day
14	f ³ /sec	f ³	Cubic feet per second
15	f ³ /min	f ³	Cubic feet per minute
16	f ³ /hr	f ³	Cubic feet per hour
17	f ³ /day	f ³	Cubic feet per day
18	gal/sec	gal	Gal per second
19	gal/min	gal	Gal per minute
20	gal/hr	gal	Gal per hour
21	gal/day	gal	Gal per day
22	gr/sec	gr	Grams per second
23	gr/min	gr	Grams per minute
24	gr/hr	gr	Grams per hour
25	gr/day	gr	Grams per day
26	kg/sec	kg	Kilograms per second
27	kg/min	kg	Kilograms per minute
28	kg/hr	kg	Kilograms per hour
29	kg/day	kg	Kilograms per day
30	lb/sec	lb	Pounds per second

NUMBER	FLOW RATE ENGINEERING UNITS	TOTALIZER ENGINEERING UNIT	DESCRIPTION
31	lb/min	lb	Pounds per minute
32	lb/hr	lb	Pounds per hour
33	lb/day	lb	Pounds per day
34	ton/min	ton	Metric Ton per minute
35	ton/hr	ton	Metric Ton per hour
36	lgl/sec	lgl	Imperial Gal per second
37	lgl/min	lgl	Imperial Gal per minute
38	lgl/hr	lgl	Imperial Gal per hour
39	lgl/day	lgl	Imperial Gal per day
40	MnL/min	MnL	Million Litr per minute
41	MnL/hr	MnL	Million Litr per hour
42	MnL/day	MnL	Million Litr per day
43	bbl/sec	bbl	Barrel per second
44	bbl /min	bbl	Barrel per minute
45	bbl /hr	bbl	Barrel per hour
46	bbl /day	bbl	Barrel per day
47	User	User	User-defined

The following selections are available: 1 second, 60 seconds (1 minute), 3600 seconds (1 Hour), 86400 seconds (1 Day). The default entry is 60 seconds. If a massbased User-defined Unit is desired, the “UD Unit Use Density” parameter must be set to “YES”. The default entry is “NO” so the Fluid STD Density parameter is not used for flow rate calculation.

6.4.6 Submenu “K-Factors Settings”

Conversion factors relative to Nitrogen are convenient to use when the flow meter main or user gas table is calibrated for Nitrogen and another gas is required to be measured.

Conversion factors relative to Nitrogen for up to 25 common gases are stored in the ZFM (see APPENDIX II). In addition, provision is made for a **user-defined** conversion factor. Conversion factors may be applied to all units of measure (except%FS unit) via local OLED/ Joystick interface or digital communication interface.

The following parameters are available for this function:

- a) K-Factor Mode: Disable, Internal Index, user-defined (default Disabled)
- b) Internal K Factor Index: 1 – 25 (from internal K-Factor table, see APPENDIX II)
- c) User-defined K-Factor: 0.001 – 999.9 (default value is 1.000).
- d) User-defined K-Factor Fluid Density: 0.002 - 99.9 (default 1.1637 gr/L)
- e) N2 Roll Back Mode: Disable, Enable (default setting is Disabled)

The "N2 Roll Back Feature" can be used if ZFM **User Gas Table** is calibrated for other Gas (not N2), but flowing fluid is different (not N2 and not the one which it was calibrated for). In this case ZFM will automatically convert flow reading first back to N2 (using **User Gas Table** "K-Factor relative to N2" parameter) and then apply selected Internal or User Defined K-Factor.



NOTE: N2 Roll Back Feature will work only with User Gas Tables (Gas Tables 1 to 10) and not applicable to Main Gas Table.



NOTE: The conversion factors will not be applied for the % F.S. engineering unit.



NOTE: If Conversion Factor is enabled and mass based units of measure are used make sure proper values of "K-Factor Fluid Density" and User Gas Table "Flowing Fluid Density" are entered.

6.4.7 Submenu "Select Gas Table"

ZFM flow meter supports multi-gas/multi-range functionality which allow users save time and money by on site rescaling the instruments to the desired gas and full scale range based on minimum and maximum supported full scale ranges (see table 5.1) for given model number (currently following gases are supported: N2, Air, O2, Argon, Helium, CO2).

ZFM is using "**Primary Calibration Table**" which was calibrated on the factory with Nitrogen and proprietary empiric K-Factors curves (individually developed by each model) to transfer calibration curve to the "**Main Gas Table**" according to desired full scale range and gas. Main Gas Calibration Table [**M0**] usually configured on the factory for flowing fluid and full scale range according to customer order. It can be reconfigured by user to desired flow range and supported gas via digital communication interface using supplied "ZFM Configuration Utility" software **Main Gas Table Rescaling** procedure.

ZFM flow meter has additional 10 **User Gas Tables** [**U1 - U10**] which can be directly calibrated with desired actual gas or reconfigured to desired gas and full scale range using Primary Gas Table (calibrated with Nitrogen) and gas conversion factors relative to nitrogen.

User Gas Calibration Tables [**U1 to U10**] usually by default are "**NOT CALIBRATED**" unless user requested to calibrate or configure some of them on the factory for particular flowing fluid and full scale range according to customer order. They can be reconfigured by user to desired flow range and flowing gas via digital communication interface using supplied "ZFM Configuration Utility" software **User Gas Table Rescaling** procedure.

G:M0 HELIUM
MO HELIUM
U01 METHANE
U02 NOT CALIBRATED
U03 NOT CALIBRATED
U04 NOT CALIBRATED
U05 NOT CALIBRATED
U06 NOT CALIBRATED

Figure 6.10 Selecting Active Gas Table



NOTE: By default the ZFM is shipped with at least one valid calibration table (unless optional additional calibrations were ordered). If instead of the valid Gas name (for example NITROGEN), the OLED screen or digital interface displays Gas designator as “NOT CALIBRATED”, then the user has chosen the Gas Table which was not calibrated. Using a “NOT CALIBRATED” Gas Table will result in erroneous reading.

6.4.8 Submenu “Flow Alarm Settings”

ZFM provides the user with a flexible Alarm/warning system that monitors the Fluid Flow for conditions that fall outside configurable limits as well as visual feedback for the user via the OLED, status LED or via a SSR output. The Flow Alarm has several attributes which may be configured by the user via OLED/Joystic interface or digital communication interface. These attributes control the conditions which cause the Alarm to occur and to specify actions to be taken when the flow rate is outside the specified conditions.

Flow Alarm conditions become true when the current flow reading is equal to or Higher/Lower than corresponding values of High and Low Flow Alarm levels.

Alarm action can be assigned with preset Delay Interval (0-3600 seconds) to activate the SSR output. Latch Mode control feature allows SSR output to be latched on or follow the corresponding Alarm status.

Following settings are available for Flow Alarm (see **Figure 6.9**):

a) Flow Alarm Mode (Tabular entry)

This function determines whether the Flow Alarm is Enabled or Disabled. The following selections are available: Enabled or Disabled. The default entry is Disabled. Alarm Mode selections can be set with the Joystick UP and DN buttons and are accepted by pressing ENT button.

b) Low Flow Alarm (Numerical entry)

The limit of required Low Flow Alarm value can be entered in increments of 0.1% from 0 - 100%F.S.

If a Low Alarm occurs, and SSR output is assigned to the Low Flow Alarm Event (see paragraph 6.4.11.4) the SSR output will be activated when the flow is less than the Low Flow Alarm value.

The Low Flow Alarm condition is also indicated on the corresponding Process Information Screen by displaying L character.



NOTE: The value of the Low Flow Alarm must be less than the value of the High Flow Alarm.

c) High Flow Alarm (Numerical entry)

The limit of required High Flow Alarm value can be entered in increments of 0.1% from 0 - 100% F.S. If a High Alarm occurs, and SSR output is assigned to the High Flow Alarm Event (see paragraph 6.4.11.4) the SSR output will be activated for when the flow reading is more than the High Flow Alarm value.

The High Flow Alarm condition is also indicated on the corresponding Process Information Screen by displaying the H character.



NOTE: The value of the High Flow Alarm must be more than the value of the Low Flow Alarm.

d) Flow Alarm Action Delay (Numerical entry)

The Flow Alarm Action Delay is a time in seconds that the Flow Rate value remains above the High limit or below the Low limit before an Alarm condition is validated. Valid settings are in the range of 0 to 3600 seconds (default value is 0, no delay).

e) Flow Alarm Power On Delay (Numerical entry)

Sometimes it is convenient to enable the Flow Alarm only after specified power-up delay interval. The mass flow meters require some warm-up time from the power-up event in order to stabilize the process variable output and get an accurate reading. "Flow Alarm Power On Delay" option allows set specified a time interval which must elapse from the device power-up event before the Flow Alarm function will be activated. Valid settings are in the range of 0 to 3600 seconds (default value is 0, no delay).

f) Flow Alarm Action Latch (Tabular entry)

The Flow Alarm Action Latch settings control the Latch feature. If SSR output is assigned to the Flow Alarm Event, in some cases, the Flow Alarm Latch feature may be desirable.

The following settings are available: Disable or Enabled. By default, the Flow Alarm is non-latching. That means the Alarm Action is indicated only while the monitored Flow Rate Value exceeds the specified set conditions.

6.4.9 Totalizers Settings

ZFM provides the user with two independent Programmable Flow Totalizers. The total volume (mass) of the flowing fluid is calculated by integrating the actual instantaneous fluid flow rate with respect to time. Totalizers reading values are stored in the EEPROM and saved every 1 second. In case of power interruption the last saved Totalizers value will be loaded on the next power on cycle, so the Totalizers reading will not be lost. Use the “Totalizer Menu” to navigate to the “Totalizer #1” or “Totalizer #2” menu options. The following settings are available for Totalizer #1 and Totalizer #2 (see **Figure 6.9**):

a) Totalizer Mode (Tabular entry)

This option determines whether Totalizer is Enabled or Disabled. The following selections are available: Enabled or Disabled. The default entry is Disabled. Totalizer Mode selections can be set with Joystick UP and DN buttons and are accepted by pressing the ENT button.



NOTE: Before enabling the Totalizer, ensure that all Totalizer settings are configured properly. Totalizer Start values must be entered in the currently active Volumetric or Mass flow engineering unit. The Totalizer will not totalize until the Process Flow Rate becomes equal to or more than the Totalizer Start value. Totalizer Event values must be entered in currently active volume or mass based engineering units. If the Totalizer Event (Action) at preset total volume feature is not required, set Totalizer Event value to zero (default settings).

b) Totalizer Flow Start (Numerical entry)

This option allows the start of the Totalizer at a preset flow rate. Totalizer will not totalize until the process flow rate becomes equal to or more than the Totalizer Flow Start value. The limit of required Totalizer Flow Start value can be entered in increments of 0.1% from 0 - 100%FS.

c) Totalizer Action Volume (Numerical entry)

This option allows the user to activate preset required action when the Totalizer reaches a preset volume. Totalizer Action Volume value must be entered in currently active volume / mass-based engineering units. Totalizer Action Event becomes true when Totalizer reading is more or equal to preset “Totalizer Action Volume”. If the Totalizer Action at preset total volume feature is not required, set “Totalizer Action Volume” value to zero (default settings).

d) Totalizer Power On Delay (Numerical entry)

Sometimes it is convenient to start the Totalizer only after specified power-up delay interval. Mass flow meters requires some warm-up time from the power-up event in order to stabilize the process variable output and get an accurate reading. “Totalizer Power On Delay” option allows set specified time interval which must elapse from the device power-up event before the Totalizer will be activated. Valid settings are in the range of 0 to 3600 seconds (default value is 0, no delay).

e) Totalizer Auto Reset (Tabular entry)

This option allows automatic reset of the Totalizer when it reaches preset Action Volume value. This feature may be convenient for batch processing when predefined volume of the fluid must be repeatedly dispensed into the process. The following selections are available: Enabled or Disabled.

The default entry is Disabled. Totalizer Auto Reset selections can be set with Joystick UP and DN buttons and are accepted by pressing the ENT button.

f) Totalizer Auto Reset Delay (Numerical entry)

This option may be desirable when the “Totalizer auto Reset” feature is enabled and predefined delay is required before new batch cycle starts . Valid settings are in the range of 0 to 3600 seconds (default value is 0, no delay).

g) Reset Totalizer (Numerical entry)

The Totalizers reading can be reset by selecting the “Reset Totalizer” menu option. A typical display with Totalizer Reset screen is shown below.

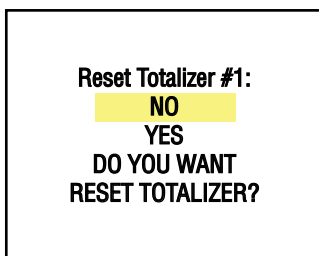

Once the “YES” option is selected, Totalizer #1 will be reset and the following confirmation screen will appear:

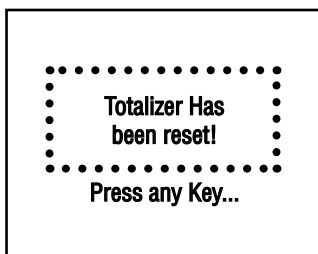

Local maintenance push button is available for manual Totalizer reset on the field for meter without OLED/Joystick option. The maintenance push button is located on the right side of the flow meter (see Paragraph 6.5 “Multi-Functional Push-button operation”).



NOTE: If Totalizer “Lock Reset Function” is enabled the “Reset” feature is not functional and Totalizer cannot be reset. “Lock Reset Function” parameter can be only changed manually using supplied “ZFM Configuration Utility” software from “Terminal” mode using ASCII “T” command with “L” argument (see ASCII Command Set table in the paragraph 10.2). By default Totalizer “Lock Reset Function” is disabled but it can be enabled by user if Totalizer reading in the user application must be preserved for the life time of the instrument.

h) Totalizer Reading Decimal Point (DP) Precision (Numerical entry)

Sometimes it is convenient to have Totalizer reading decimal point precision much lower than Flow Rate reading (for example when Totalizer accumulate reading over long period of time). “Totalizer DP Precision” parameter allows to decrease number of digits after decimal point for Totalizer reading from 0 to -5. For example if Flow Reading has precision 3 digits after decimal point setting “Totalizer DP Precision” parameter to -2 will result in Totalizer reading precision 1 digit after decimal point.

6.4.10 Submenu “Pulse Output”

The flow Pulse Output is operates independently from Totalizers and is based on configuration settings (see **Figure 6.9**) which can provide pulse frequency proportional to instantaneous fluid flow rate.

The OLED/Joystick interface and digital communication interface commands are provided to:

- Enable/Disable Pulse Output
- Start Pulse Output at preset flow rate (0.0 – 100.0 %F.S.)
- Configure the Unit/Pulse value (in current engineering units)
- Configure Pulse Active On Time (50 - 6553 ms)



NOTE: The Pulse Output minimum Active On time is a 50 milliseconds (.05 second). The Pulse Output cannot operate faster than one pulse every 100 millisecond (.1 second). A good rule to follow is to set the Unit/Pulse value equal to the maximum flow in the same units per second. This will limit the pulse rate to no faster than one pulse every second.

For example: Maximum flow rate = 120 gr/min
(120 gr/min = 2 gr/sec)
If unit per pulse is set to 120 gr per pulse, the Pulse Output will pulse once every minute.

If unit per pulse is set to 2 gr per pulse, the Optical Pulse Output will pulse once every second.

The Pulse Output incorporates Pulse output queue, which accumulates pulses if the Pulse Output is accumulating process flow faster than the pulse output hardware can produce. The queue will allow the pulses to “catch up” later if the flow rate decreases. A better practice is to slow down the Pulse Output by increasing the value in the Unit/Pulse setting in the Pulse Output menu (see **Figure 6.9**).



NOTE: If Pulse Output feature is required, the Solid State Relay (SSR) output must be assigned to the “Pulse Output” function (see Paragraph 6.4.11.4). Pulse output signal will be accessible via SSR output (pins 8 and 9) on the ZFM 9-pins D-connector (see Figure 3.1 for proper wiring connections).

6.4.11 General Settings

6.4.11.1 Display and Process Information (PI) Screens

The local OLED Process Information screens can be configured to be static (manual control) or dynamic (automatic sequencing). In the static mode pressing the Joystick UP allows the user to page through the PI screens in the forward direction, pressing the Joystick DN, pages through the PI screens in the reverse direction. When the last PI screen is reached, the firmware “wraps around” and scrolls to the initial PI screen once again.



NOTE: PI screens which are not Enabled (masked) will be skipped. PI Screen #1 (Flow Rate, Fluid Name and Totalizer #1 reading) cannot be Disabled.

The following settings are available for OLED Display:

a) Display Mode

This option determines whether Display screens are in static (manual control) or dynamic (automatic sequencing) mode. The following selections are available: Static or Dynamic. The default entry is: Static (manual control).

b) Screen Cycle Interval

This menu selection defines time interval in seconds for each PI screen to be displayed in the dynamic mode (automatic sequencing). Screen Cycle Time can be set to any value in the range between 1 to 3600 seconds (numerical entry).

c) PI Screen Mask

Using Screen Mask settings the user can enable (unmasked) or disable (masked) up to 6 different process variable combinations (see **Figure 6.4**). The screen is Enabled if check box right across from corresponding screen is checked. If screen is disabled, it will be skipped. By default the unit is shipped from the factory with all PI screens enabled.

Screen Masc:
Screen #1 [*]
Screen #2 [*]
Screen #3 [*]
Screen #4 [*]
Screen #5 [*]
Screen #6 [*]

Figure 6.4 PI Screen Mask

In the example shown above, all PI screens are enabled. Each PI screen is assigned to a corresponding bit in the PI Screen Register. In order to change PI Screen mask settings the user should select the desired screen using Joystick UP and DN buttons and then press **RIGHT** button. The asterisk will appear/disappear on the right side of the corresponding screen. The asterisk signifies that the screen is enabled. In order to disable the screen, the corresponding asterisk must be removed. Use the Joystick ENT button to accept and save new PI Screen Mask settings in the device's nonvolatile memory.

d) OLED Operational Brightness (Numerical entry)

Using OLED Operational Brightness settings the user can adjust the desired level of the OLED brightness during normal operation (when screen saver is not active). The OLED brightness has 256 different levels.



NOTE: By default the brightness level is set to 127 which is the optimal level for room temperature (20 °C or 70 °F).

e) OLED Screen Saver Mode

OLED is subject to burn-in. It can retain images on the screen temporarily and in some cases even permanently, if it's left static for too long. In order to mitigate this phenomenon the screensaver feature is provided.

Screensaver feature has 4 different modes:

- Disabled (no screensaver)
- Low Brightness
- Vertical Scrolling
- OLED Off

f) OLED Screen Saver (SS) Time Out (Numerical entry)

This menu selection defines time interval in seconds from the moment the local **Esc** button or Joystick interface was last used (or if they were not used, from the power up event) to the moment the Screensaver feature is activated. Each time user activates local **Esc** button or Joystick the OLED brightness reverted to normal "Operational Brightness Level", the internal timer resets to zero and starts new delay cycle. Default setting is 900 seconds (15 minutes).

g) OLED Screen Saver Brightness (Numerical entry)

Using OLED Screen Saver Brightness settings the user can adjust the desired level of the OLED brightness during "Low Brightness" screensaver mode (when screen saver is active). The brightness has 127 different levels.



NOTE: If Screen Saver mode is active and has been change, new settings will be activated in the next Screen Saver cycle (after Esc button or joystick was activated to disable currently active screen saver). OLED "Screen Saver Brightness Level" parameter is only applicable for "Low Brightness" Screen Saver mode. In "Vertical Scrolling" mode the normal operational brightness level will be activated. If OLED display is not used in the user application (e.g. meter is installed in the remote enclosure) it is recommended set the Screen Saver mode to "OLED Off".

h) Flow Rate Precision (Tabular entry)

ZFM Flow Meter calculates Flow Rate Precision automatically based on selected units of measure and current gas table full scale flow rate to keep stable reading. By default the Flow Rate Precision is set to "Normal". In case if more digits after decimal point is required user can change decimal point precision to "Elevated" level (one more digit after decimal point).



NOTE: In some cases selecting "Elevated" precision may result in unstable reading (last digit constantly changes). In this case it is recommended to switch decimal point precision to "Normal" level.

6.4.11.2 Submenu "Communication Port Settings"

This menu selection allows the configuration of a main digital communication interface speed (Baud rate) and device RS485 bus address (only applicable for optional RS485 interface)

The following settings are available for "Communication Settings" (see **Figure 6.9**):

a) Baud Rate Settings (Tabular entry)

This option determines device digital communication interface speed (Baud rate) and can be set to one of the following:

- 1200
- 2400
- 4800
- 9600
- 19200
- 38400
- 57600
- 115200

By default the device shipped from factory with baud rate set to 9600.



NOTE: The baud rate set on the ZFM device should always follow the baud rate of the host PC or PLC it connected to.

b) RS485 Bus Address (Numerical entry)

The standard ZFM comes with an RS232 interface and does not support bus addressing. The optional RS485 interface has two hexadecimal characters of the address which must be assigned. By default each flow meter is shipped with RS485 address set to 11 hexadecimal. When more than one device is present on RS485 bus, each device should have a unique address. The two characters of the address in the hexadecimal representation can be changed from 01 to FF.



NOTE: Address 00 is reserved for global addressing. Do not assign, the global address for any device. When command with global address is sent, all devices on the RS485 bus execute the command but do not reply with an acknowledge message.



NOTE: Do not assign the same RS485 address for two or more devices on the same RS485 bus. If two or more devices with the same address are connected to the one RS485 network, a communication collision will take place on the bus and communication errors will occur.

RS485 address setting is not used for ZFM's with RS232 interface.

6.4.11.3 Submenu “Modbus Interface” (optional feature)

If ZFM flow meter is equipped with Modbus interface this menu selection allows change Modbus device ID (address) and communication parameters.

Modbus is a standard protocol developed by A.E.G. Schneider. ZFM only supports Modbus RTU version. Modbus RTU enables a computer or PLC to read and write directly to registers containing the meter parameters (see technical document #TD-ZFMMOD-0415 "Modbus RTU slave interface for AALBORG digital mass flow instruments" for detailed description of supported Modbus functions and registers).

The following parameters are available for “Modbus Settings” (see **Figure 6.9**):

a) Device ID (Address) (Numerical entry)

Decimal representation (range from 1 to 247). By default all ZFM meter equipped with ModBus interface shipped from the factory with "Device ID" parameter set to decimal 11.



NOTE: Do not assign the same ID address for two or more devices on the same Modbus segment. If two or more devices with the same address are connected to the one Modbus network, a communication collision will take place on the bus and communication errors will occur.

b) Baud Rate Settings (Tabular entry)

This option determines device Modbus interface speed (Baud rate) and can be set to one of the following:

1200
2400
4800
9600
19200
38400
57600
115200

By default the device shipped from factory with baud rate set to 9600.



NOTE: If multiple meter are connected to Modbus Master controller device, they all should have the same baud rate settings as the Master.

c) Modbus Communication Parity (Tabular entry)

This parameter can be set to one of the following: None, Odd, Even. Parity parameter by default is set to "None". In real application this parameter should follow "Parity" settings used in Modbus Master controller.

d) Modbus Communication Stop Bit (Tabular entry)

This parameter can be set to one of the following: One (1) or Two (2). Stop Bit parameter by default is set to 2. In real application this parameter should follow Stop Bit settings used in Modbus Master controller.

6.4.11.4 Relay Assignment

One set of the SPST Solid State Relay output is provided to actuate user supplied equipment. It is programmable via digital interface or local OLED/Joystick interface such that the relay can be made to switch when a specified event occurs (e.g. when a low or high flow alarm limit is exceeded or when one of the two totalizers reaches a specified value).

USER CAN CONFIGURE RELAY ACTION FROM 10 DIFFERENT OPTIONS:

- **Disabled:** No Action (output is not assigned to any events and relay is not energized).
- **Low Flow Alarm :** (L) Low Flow Alarm condition.
- **High Flow Alarm :** (H) High Flow Alarm condition.
- **Range between H&L :** (R) Range between High and Low Flow Alarm condition.
- **Totalizer#1 > Limit :** (T1) Totalizer#1 reached preset limit volume.
- **Totalizer#2 > Limit :** (T2) Totalizer#2 reached preset limit volume.
- **Pulse Output:** Pulse Output Queue is overloaded.
- **Alarm Events:** One or more Alarm Events are active.
- **Diagnostic Events:** One or more Diagnostic Events are active.
- **Manual On (Enabled) :** (M) Activated regardless of the Alarm, Totalizers or other conditions. By default relay is disabled (not energized).



NOTE: Relay terminals are accessible via ZFM 9 pins D-connector (pins 8 and 9) and have maximum 48VDC voltage and 0.4A current ratings. See Figure 3.1 for proper wiring connections.

6.4.11.5 Analog Output configuration

ZFM series Mass Flow Meters are equipped with calibrated 0-5 Vdc, 0-10 Vdc and 4-20 mA output signals. Following options are provided for analog output:

a) Analog Output Mode (Tabular entry)

User can select one of the following:

0-5 Vdc (3000 ohms min load impedance).

0-10 Vdc (5000 ohms min load impedance).

4-20 mA (Sourcing type, 500 ohms maximum current loop resistance).



NOTE: Before changing “Analog Output Interface” mode make sure the load impedance is within corresponding limits stated above. Failure to do so might cause damage to analog output circuitry or erroneous reading.



CAUTION: The 4-20 mA current loop output is self-powered (sourcing non-isolated type). Do NOT connect an external voltage source to the output signals. See Paragraph 3.2 for proper wiring connections.

b) Analog Output Calibration



NOTE: The analog outputs available in the ZFM meter were calibrated at the factory. There is no need to perform analog output calibration unless the DAC IC, output amplifier IC or passive components from analog output circuitries were replaced or it was suggested by factory customer support representative. Any alteration of the analog output scaling variables in the EEPROM table will VOID calibration warranty supplied with the instrument.

The ZFM analog output calibration involves calculation and storing the offset and span variables in the EEPROM based on two calibration points (0 and 100% F.S.). The 0-5 (0-10)Vdc outputs have only scale variable and 4-20 mA output has offset and scale variables.

Power up the ZFM instrument for at least 30 minutes prior to commencing the calibration procedure. Observe current analog output mode settings.

For 0-5 or 0-10 Vdc output calibration:

Connect the corresponding type of measurement device (voltmeter) to pins 2 (plus) and 3 (minus) of the 9-pin D-connector.

For 4-20 mA output calibration:

Connect the corresponding type of measurement device (ammeter) to pins 2 (plus) and 6 (minus) of the 9-pin D-connector.

Follow firmware prompts and adjust calibration point values according to measurement device reading using Joystick Up, Dn, Left, Right buttons. If calibration must be aborted, press ESC button. When calibration is completed firmware will display new offset and span values and ask the user to press the Joystick ENT button to save new calibration variables to EEPROM or ESC to abort calibration and exit without saving. In the end, the firmware will prompt with confirmation message.

c) Analog Output Test

This menu selection has to be used only for troubleshooting purpose when requested by customer support representative. It allows emulating analog output reading by entering desired flow rate reading in % of full scale (0.0 to 110.0%).



CAUTION: When “Analog Output Test” is selected the output reading does not represent actual Process Information (PI) variable (flow rate reading).

Adjust desired flow output value using Joystick Up, Dn, Left, Right buttons. Press Joystick Ent button to activate analog output. If analog output test mode must be aborted, press ESC button. Once test mode is deactivated the analog output should represent actual flow rate reading.

Adjust desired flow output value using Joystick Up, Dn, Left, Right buttons. Press Joystick Ent button to activate analog output. If analog output test mode must be aborted, press ESC button. Once test mode is deactivated the analog output should represent actual flow rate reading.

6.4.11.6 Status LED Settings

ZFM series Mass Flow Meters are equipped with dual color LED which allows signaling various different events with combination of three color (RED, GREEN, AMBER) and specific time pattern. Status LED operation can be adjusted (filtered) for different events indication based on custom user needs.

Status LED can be set to following modes (see **Figure 6.9**).

1. Normal, supports following events:

- 1.1 Auto Zero Failure (constant RED)
- 1.2. Fatal Error (constant RED, require system reset for recovery)
- 1.3. User entry via side Push Button (specific pattern limited by time interval up to 35 seconds)
- 1.4. Power Up Sensor Warm Up interval (3 minutes) constant UMBER (can be interrupted only by User PB entry or Fatal Error).

2. Monitoring Flow Alarm and Flow Totalizers events (default settings):

- 2.1 High Flow Alarm RED/OFF (alternating every second)
- 2.2 Low Flow Alarm GREEN/OFF (alternating every second)
- 2.3 Totalizer#1 Event AMBER/OFF (alternating every second)
- 2.4 Totalizer#2 Event AMBER/OFF (alternating every 2 second)
- 2.5 High Flow Alarm and Totalizer#1 Event RED/AMBER (alternating every second)
- 2.6 High Flow Alarm and Totalizer#2 Event RED/AMBER (alternating every 2 second)
- 2.7 Low Flow Alarm and Totalizer#1 Event GREEN/AMBER (alternating every second)
- 2.8 Low Flow Alarm and Totalizer#2 Event GREEN/AMBER (alternating every 2 second)
- 2.9 Both Totalizer#1 and Totalizer#2 Events AMBER/OFF (On for 3 seconds, off for 1 second)
- 2.10 High Flow Alarm and both Totalizers Events AMBER/RED (AMBER for 3 seconds, RED for 1 second)
- 2.11 Low Flow Alarm and both Totalizers Events AMBER/GREEN (AMBER for 3 seconds, GREEN for 1 second)

3. Monitoring Alarm Events only (any active Alarm event will trigger LED indication): GREEN/OFF (alternating every second)

4. Monitoring Diagnostic Events only (any active Diagnostic event will trigger LED indication): RED/OFF (alternating every second)

5. Test and Configuration Communication Interface Monitoring:

- 5.1 Data Received (RX activity) RED LED flashing momentarily (about 200 ms or less)
- 5.2 Data Transmitted (TX activity) GREEN LED flashing momentarily (about 200 ms or less)

6. Modbus Communication Interface Monitoring (optional):

- 6.1 Data Received (RX activity) RED LED flashing momentarily (about 200 ms or less)
- 6.2 Data Transmitted (TX activity) GREEN LED flashing momentarily (about 200 ms or less)

6.4.11.7 Signal Conditioner Settings



CAUTION: The signal conditioner parameters for your meter were set on the factory to keep best performance. Do not change Signal Conditioner parameters unless instructed by factory technical support representative! Consult factory for more information.

6.4.12 Sensor Zero Calibration

The ZFM includes an auto zero function that, when activated, automatically adjusts the mass flow sensor to read zero. The initial zero adjustment for your ZFM was performed at the factory. It is not required to perform zero calibration unless the device has zero reading offset with no flow conditions.



NOTE: Before performing Zero Calibration, make sure the device is powered up for at least 15 minutes and absolutely no flow condition is established. For better result it is recommended start Auto Zero at least after 30 minutes after power was applied to the flow meter

Shut off the flow of gas into the ZFM Flow Meter. To ensure that no seep-age or leak occurs into the meter, it is good practice to temporarily disconnect the gas source. The Auto Zero may be initiated locally using optional OLED/Joystick interface (see **Figure 6.9**) or by pressing the multi-functional maintenance push button, which is located on the right side of the flow meter or via digital communication interface (see **Figure 6.12** "ZFM interface connectors and maintenance push button").

To start Auto Zero locally using OLED/Joystick interface, navigate to "Sensor Zero Calibration" menu selection and select "Start Auto Zero Now". On the ZFM with optional OLED, the following screen will appear:

Device Information:
NO
YES
Absolutely no Flow!!!
DO YOU WANT
START AUTO ZERO?

To start Auto Zero select "YES" option and push Joystick Ent button. The status LED will start flashing RED/GREEN (alternating every 2 seconds). The following screen will appear:

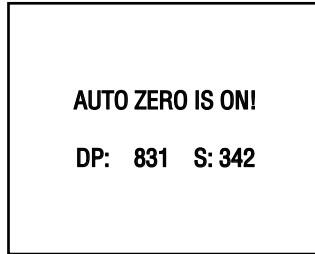

NOTE: Actual DP and Sensor ADC counts reading for your instrument, may be different.

ZFM internally represents flow reading processed by A/D converter in counts from -60000 to 60000. Zero reading is assigned to 0 counts. Zero Reading 0 counts represent ideal perfect zero adjustment. DP Zero Control value can be automatically adjusted by instrument from 0 to 1023.



NOTE: Internal Auto Zero process has about 8 seconds time constant per one iteration and may take 2 to 5 minutes to complete. Internal Auto Zero performs zero reading adjustment while zero reading is outside of Auto Zero Tolerance (default +/- 7 counts) range and will stop when zero reading is inside of this range. Use "Manual Zero" adjustment if better zero adjustment is required.



NOTE: Do not decrease "Auto Zero Tolerance" value below 7 counts, doing so may cause Auto Zero to fail. Increasing "Auto Zero Tolerance" value above 15 counts will increase chances of successful result but will lead to some zero shift.

The nominal value for a fully balanced sensor is 0 Counts. If the ZFM's digital signal processor was able to adjust the Sensor reading within 0 ± 7 counts (within default **Auto Zero Tolerance**), then **Auto Zero** is considered successful. The status LED will return to a constant GREEN light and the screen below will appear:

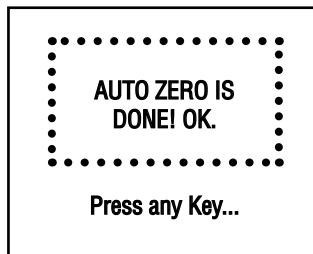

If the device was unable to adjust the Sensor reading to within 0 ± 7 counts, then Auto Zero is considered as unsuccessful. The constant RED light will appear on the status LED. The user will be prompted with the “Auto Zero ERROR!” screen.



NOTE: For initiating Sensor Auto Zero Calibration using multifunctional maintenance push button see Paragraph 6.5.

6.4.13 Submenu “Alarms and Diagnostic”

ZFM equipped with an Alarm and Diagnostic Events Registers which are available via digital interface and on optional OLED screen indication. The **Alarm Event Register** monitors non critical alarm events related to the meter settings and process variables. The **Diagnostic Event Register** monitors critical diagnostic events related to the meter performance and hardware peripherals conditions.

6.4.13.1 Alarm Event Register

The following alarm events are supported:

Table 6.2 ALARM EVENTS REGISTER		
EVENT NUMBER	ALARM EVENTS DESCRIPTION	OLED BIT CODE
1	High Flow Alarm	0
2	Low Flow Alarm	1
3	Flow Between High and Low Limits	2
4	Totalizer#1 Exceed Set Event Volume Limit	3
5	Totalizer#2 Exceed Set Event Volume Limit	4
6	Pulse Output Queue overflow	5
7	Flow Rate above Limit	6
8	Password Event (attempt to change password)	7
9	Power On Event (power on delay timer > 0)	8

There are actually three separate registers:

- The **Status Alarm Event Register** holds Each active Alarm event (read only).
- The **Mask Alarm Event Register** allows to Enable or Disable monitoring for particular event.
- The **Latch Alarm Event Register** allows to Enable or Disable latch feature for particular event.

a) Status Alarm Event Register (Read Only)

Each active Alarm Event will be indicated on the OLED screen. In addition the total number of currently active events will be displayed on the first line (header). A typical display without active Alarm Events is shown below.

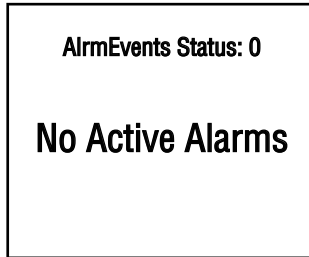

A typical display with two active Alarm events is shown below.

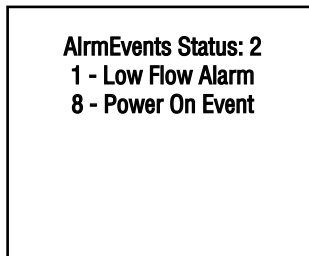

If more than 7 events are displayed, the user can use Joystick UP and DN buttons to scroll and see all indicated events. If the event is not latched in the Latch Alarm Event Register it may appear and disappear from the status screen and will be indicated as long as actual event is taking place.

b) Mask Alarm Event Register (Tabular entry)

Using the **Mask Alarm Event Register** settings, the user can individually enable (unmask) or disable (mask) each event. The event is enabled if the asterisk sign [*] is set

to the right across from corresponding event. If the event is disabled, it will not be processed and indicated in the Events status Register even actual conditions for the event have occurred. By default the unit is shipped from the factory with only one event active: “8 – Power On Event”. All other events are disabled. A typical display with Mask Alarm Event Register selection is shown below.

Alarm Events Mask Reg:	
2 - Range b/w H-L	[*]
3 - Tot#1> Limit	[]
4 - Tot#2> Limit	[]
5 - PulseOut Queue	[]
6 - FlowOver Limit	[]
7 - Password Event	[]
8 - Power On Event	[]

In the example shown above, latch features for all events are disabled, except event #2. In order to change **Mask Alarm Event Register** settings, the user should select the desired event using Joystick UP and DN buttons and then press the **RIGHT** button. The asterisk will appear/disappear on the right side of the corresponding event. The asterisk represents that the event is enabled. In order to disable event, the corresponding asterisk must be removed. Use the ENT button to accept and save the new Mask Alarm Event Register settings in the device’s nonvolatile memory.

c) Latch Alarm Event Register (Tabular entry)

Using **Latch Alarm Event Register** settings the user can enable (unmask) or disable (mask) the latch feature individually for each event. The event is enabled if an asterisk sign [*] is set to the right across from the corresponding event. If the event is not latched (no asterisk across from the corresponding event) it may appear and disappear from the status screen. It will be indicated as long as the actual event is taking place. By default the unit is shipped from the factory with latch feature disabled for all events. A typical display with **Latch Alarm Event Register** selection is shown below.

Alarm Events Latch Reg:	
2 - Range b/w H-L	[]
3 - Tot#1> Limit	[]
4 - Tot#2> Limit	[]
5 - PulseOut Queue	[]
6 - FlowOver Limit	[]
7 - Password Event	[]
8 - Power On Event	[]

In the example shown above, latch features for all events are disabled. In order to change **Latch Alarm Event Register** settings, the user should select the desired event using Joystick UP and DN buttons and then press the **RIGHT** button. The asterisk will appear/disappear on the right side of the corresponding event. The asterisk represents that the latch feature is enabled. In order to disable latch feature, the corresponding asterisk must be removed. Use ENT button to accept and save new Latch Alarm Event Register settings in the device’s nonvolatile memory.

d) Reset Status Alarm Event Register (Tabular entry)

The **Status Alarm Event Register** can be reset by selecting “**Reset AlarmEvent Reg**” menu option. A typical display with **Status Alarm Event Register** reset screen is shown below.



Once the “YES” option is selected, the Event Register will be reset and the following conformation screen will appear.

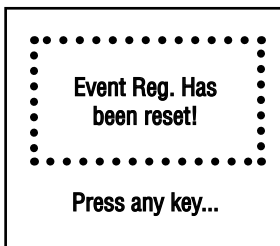

NOTE: Any Alarm Events that may have occurred (Event 0 to Event 8) are stored in the internal status register. All detected events (if corresponding bit in the latch register is not masked) remain stored until the register is manually reset (by key-pad or by means of the digital communication interface). If event corresponding bit in the latch register is masked (disabled), the event will be indicated as long as it is active (no latching). The status Alarm Event Register is mapped to the SRAM (volatile memory). In case of power interruption the status Event Register will be automatically reset.

6.4.13.2 Diagnostic Events Register

The following diagnostic events are supported:

Table 6.3 ALARM EVENTS REGISTER		
EVENT NUMBER	ALARM EVENTS DESCRIPTION	OLED BIT CODE
1	CPU Temperature Too High	0
2	Sensor Compartment Temp. High	1
3	Sensor Heater Out of Range	2
4	Sensor Resistance Out of Range	3
5	2.5 Vdc Reference Out of Range	4
6	Analog Output Alarm is On	5
7	UART Serial Communication Error	6
8	Modbus Interface Error	7
9	EEPROM R/W Error	8
10	Auto Zero Failure	9
11	Fatal Error (unrecoverable error)	A

There are actually three separate registers:

- The **Status Diagnostic Event Register** holds Each active Alarm event (read only).
- The **Mask Diagnostic Event Register** allows to Enable or Disable monitoring for particular event.
- The **Latch Diagnostic Event Register** allows to Enable or Disable latch feature for particular event.

a) Status Diagnostic Event Register (Read Only)

Each active Diagnostic Event will be indicated on the OLED screen. In addition the total number of currently active events will be displayed on the first line (header). A typical display without active Diagnostic Events is shown below.

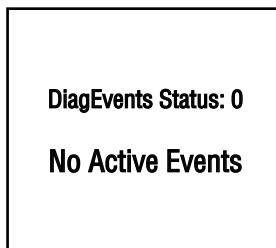

A typical display with two active Diagnostic events is shown below.

<p>AlarmEvents Status: 2 9 - Auto Zero Failure 6 - UART ERROR</p>

If more than 7 events are displayed, the user can use Joystick UP and DN buttons to scroll and see all indicated events. If the event is not latched in the Latch Diagnostic Event Register it may appear and disappear from the status screen and will be indicated as long as actual event is taking place.

b) Mask Diagnostic Event Register (Tabular entry)

Using the Mask **Diagnostic Event Register** settings, the user can individually enable (unmask) or disable (mask) each event. The event is enabled if the asterisk sign [*] is set to the right across from corresponding event. If the event is disabled, it will not be processed and indicated in the Events status Register even actual conditions for the event have occurred. By default the unit is shipped from the factory with only one event active: “0 – CPU Temperature Too High”. All other events are disabled. A typical display with Mask **Diagnostic Event Register** selection is shown below.

DiagEvents Mask Reg:	
0 - CPU Temp. High	[*]
1 - Sens Temp High	[]
2 - SH OutOf Range	[]
3 - SR OutOf Range	[]
4 - VR OutOf Range	[]
5 - AnalogOut Alarm	[]
6 - SerComm. Error	[]

In the example shown above, latch features for all events are disabled, except event #2. In order to change **Mask Diagnostic Event Register** settings, the user should select the desired event using Joystick UP and DN buttons and then press the **RIGHT** button. The asterisk will appear/disappear on the right side of the corresponding event. The asterisk represents that the event is enabled. In order to disable event, the corresponding asterisk must be removed. Use the ENT button to accept and save the new **Mask Diagnostic Event Register** settings in the device’s nonvolatile memory.

c) Latch Diagnostic Event Register (Tabular entry)

Using Latch Diagnostic Event Register settings the user can enable (unmask) or disable (mask) the latch feature individually for each event. The event is enabled if an asterisk sign [*] is set to the right across from the corresponding event. If the event is not latched (no asterisk across from the corresponding event) it may appear and disappear from the status screen. It will be indicated as long as the actual event is taking place. By default the unit is shipped from the factory with latch feature disabled for all events. A typical display with **Latch Diagnostic Event Register** selection is shown below.

DiagEvents Latch Reg:	
0 - CPU Temp. High	[*]
1 - Sens Temp High	[]
2 - SH OutOf Range	[]
3 - SR OutOf Range	[]
4 - VR OutOf Range	[]
5 - AnalogOut Alarm	[]
6 - SerComm. Error	[]

In the example shown above, latch features for all events are disabled, except event #0. In order to change Mask Diagnostic Event Register settings, the user should select the desired event using Joystick UP and DN buttons and then press the **RIGHT** button. The asterisk will appear/disappear on the right side of the corresponding event. The asterisk represents that the event is enabled. In order to disable event, the corresponding asterisk must be removed. Use the ENT button to accept and save the new Mask Diagnostic Event Register settings in the device's nonvolatile memory.

d) Reset Status Diagnostic Event Register (Tabular entry)

The Status Diagnostic Event Register can be reset by selecting “Reset DiagEvent Reg” menu option. A typical display with Status Diagnostic Event Register reset screen is shown below.



Once the “YES” option is selected, the Event Register will be reset and the following conformation screen will appear.

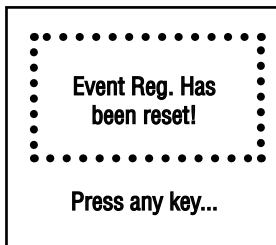

6.4.13.3 SAR ADC Analog Input Diagnostic (read only)

This menu selection provides raw or average (filtered) values of the ADC counts and voltage levels for analog input circuitry troubleshooting in the different parts of the instrument (read only). A typical display with ADC Input Counts screen is shown below.

1:1150	VS:1.853
2:1189	SC: 26.7C
8:3092	VR:2.495
9:1763	SH:11.331



NOTE: Actual content of the SAR ADC Diagnostic screen may vary depending on the model and device configuration. Consult factory customer support representative for more details about SAR ADC troubleshooting.

6.4.13.4 Flow Sensor SD ADC Diagnostic (read only)

This menu selection provides raw, averaged (filtered), DRC compensated, and NLEF values of the sensor SD ADC counts which may be useful for DSP troubleshooting (read only). A typical display with SD ADC Input Counts screen is shown below.

SensorRaw:	26504
SenRawAvr:	26508
SensorDRC:	26531
SenDRCAvr:	26530



NOTE: Actual content of the SAR ADC Diagnostic screen may vary depending on the model and device configuration. Consult factory customer support representative for more details about SAR ADC troubleshooting.

6.4.13.5 Analog Output and PO Queue Diagnostic (read only)

This menu selection provides information about meter Analog Output settings and DAC counts as well as Pulse Output Queue register value which may be useful for Analog Output and PO circuitry troubleshooting (read only). A typical display with Analog Output and PO Queue screen is shown below.

A.Output:	4-20mA
DAC Upd:	Enabled
DAC Counts:	34881
PO Queue:	0/100



NOTE: Actual content of the Analog Output and PO Queue Diagnostic screen may vary depending on the model, device configuration and meter operational state. Consult factory customer support representative for more details about Analog Output and PO troubleshooting.

6.4.13.6 CPU Temperature and Sensor Temperature Compensation (STC) Algorithm Diagnostic (read only)

This menu selection provides information about current CPU Temperature as well as different parameters of the Sensor Temperature Compensation (STC) Algorithm which may be useful for meter troubleshooting (read only). A typical display with CPU Temperature and STC diagnostic screen is shown below.

CPU: 40.2 T:	1.0
SC: 27.0	27.5 °C
STC:E	0.0c/°C
SCom:26642	26642



NOTE: Actual content of the CPU Temperature and STC Diagnostic screen may vary depending on the model, device configuration and meter operational state. Consult factory customer support representative for more details about CPU Temperature and STC troubleshooting.

6.5 Multi-Functional Push-button operation

ZFM provides the user with the micro push-button switch accessible via small hole on the right side of the instrument (see **Figure 6.12**), which can be used to select/start some important actions for the instrument. The micro push-button switch functionality available on all ZFM models in both analog and digital operation mode.

Pressing a switch shortly (< 2 sec) by accident will not cause unwanted actions of instrument and will not change status LED indication.

Pressing a switch continuously longer than 2 sec but less than 6 sec will not cause unwanted actions of instrument but will change status LED indication (the RED LED will flash every 2 seconds). This state indicates that instrument is ready to initiate action.

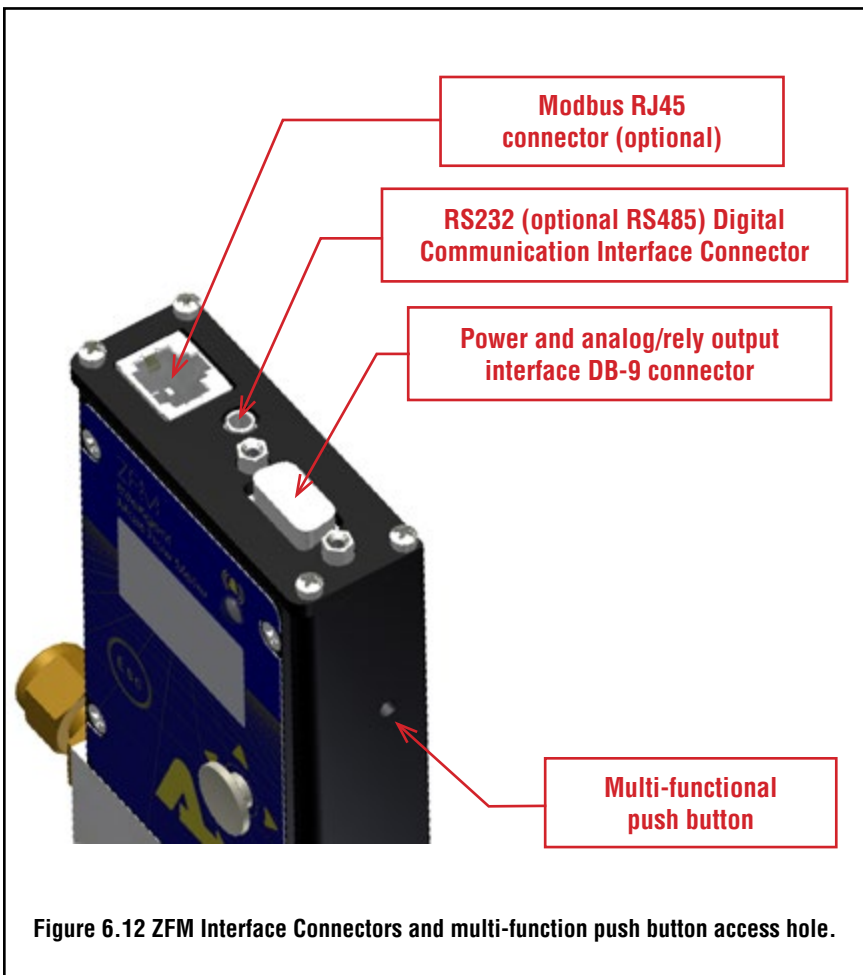

Figure 6.12 ZFM Interface Connectors and multi-function push button access hole.

Status LED Indication	Time kept Pushed	Instrument Action
RED Flashing On/ Off every 2 seconds	2 – 6 sec	Pressing a switch shortly (< 2 sec) by accident will not cause unwanted actions of instrument and will not change status LED indication. Pressing a switch continuously longer than 2 sec but less than 6 sec will not cause any actions but will change status LED indication (the RED LED will flash every 2 seconds). This state indicates that instrument is ready to initiate action.
Amber Flashing On/ Off every 2 seconds	6 – 12 sec	Releasing the switch during this pattern will Reset instrument. Instrument program will be restarted and all warning and error message will be cleared. During start-up instrument will perform a self-test
Green Flashing On/ Off every 2 seconds	12 – 18 sec	Releasing the switch during this pattern will start Sensor Auto Zero Calibration. NOTE: First make sure there is absolutely no flow and instrument is connected to power for at least 30 minutes!
RED Constantly On User has 10 seconds window to select which Totalizer has to be reset	18 – 24 sec	Releasing the switch during this pattern will switch user push button to Totalizers reset mode. User can start Push Button entry during next 10 seconds. User can select which Totalizer to reset based on number of times PB is pressed. When PB is pressed Green LED is turned On. In order to validate single Push action do not release PB until Green LED turns Off (approximately 2 sec).
	2 sec. until green LED turns Off	Pressing Push Button one time during 10 seconds window will Reset Totalizer #1. When Push Button is released the RED LED is turned On (ready for next pressing).
	2 sec. until green LED turns Off	Pressing Push Button two times during 10 seconds window will Reset Totalizer #2. When Push Button is released the RED LED is turned On (ready for next pressing).
	2 sec. until green LED turns Of	Pressing Push Button three time during 10 seconds window will Reset both Totalizer #1 and Totalizer #2.

LED indications using Push button during normal running mode.



NOTE: If user does not press PB within 10 second time frame or kept PB pressed for time interval less than required (approximately 2 seconds or until Green LED turns Off) no action will take place. PB entry will reset to default state and Green LED will be turned On.

7. MAINTENANCE

7.1 Introduction

It is important that the ZFM Mass Flow Meter is only used with clean, filtered gases. Liquids may not be metered. Since the RTD sensor consists, in part, of a small capillary stainless steel tube, it is prone to occlusion due to impediments or gas crystallization. Other flow passages are also easily obstructed.

Therefore, great care must be exercised to avoid the introduction of any potential flow impediment. To protect the instrument, a 50 micron (ZFM 17) or 60 micron (ZFM 37/47/57/67/77) filter is built into the inlet of the flow transducer. The filter screen and the flow paths may require occasional cleaning as described below. There is no other recommended maintenance required. It is good practice, however, to keep the meter away from vibration, hot or corrosive environments and excessive RF or magnetic interference. If periodic calibrations are required, they should be performed by qualified personnel and calibrating instruments, as described in section 8. It is recommended that units are returned to Aalborg® for repair service and calibration.



CAUTION: TO PROTECT SERVICING PERSONNEL IT IS MANDATORY THAT ANY INSTRUMENT BEING SERVICED IS COMPLETELY PURGED AND NEUTRALIZED OF TOXIC, BACTERIOLOGICALLY INFECTED, CORROSIVE OR RADIOACTIVE CONTENTS.

7.2 Flow Path Cleaning

Before attempting any disassembly of the unit for cleaning, try inspecting the flow paths by looking into the inlet and outlet ends of the meter for any debris that may be clogging the flow through the meter. Remove debris as necessary. If the flow path is clogged, proceed with steps below.

Do not attempt to disassemble the sensor. If blockage of the sensor tube is not alleviated by flushing through with cleaning fluids, please return meter for servicing.



CAUTION: DISASSEMBLY MAY COMPROMISE CURRENT CALIBRATION. After RFE and flow pass cleaning a recalibration is needed. Aalborg® offers professional calibration support. Contact your local distributor for cleaning and recalibration options.

7.2.1 Restrictor Flow Element (RFE)

The Restrictor Flow Element (RFE) is a precision flow divider inside the transducer which splits the inlet gas flow by a preset amount to the sensor and main flow paths. The particular RFE used in a given Mass Flow Meter depends on the gas and flow range of the instrument.

7.2.2 ZFM 17 Models

a) Filter Screen

Unscrew the inlet compression fitting of meter. Note that the 50 micron filter screen is connected to the inlet fitting. Using 1/4 inch hex key carefully unscrew filter plug and remove it from the inlet fitting. The filter screen will now become visible. Push the screen out through the inlet fitting. Clean or replace each of the removed parts as necessary. If alcohol is used for cleaning, allow time for drying.

b) RFE assembly

Unscrew the inlet compression fitting of meter. The retaining ring becomes visible inside of the meter main flow pass. Using internal ring plier tool remove retaining ring and compression spring. The RFE assembly will now become visible. Pull the RFE assembly out from the meter main flow pass. Clean or replace each of the removed parts as necessary. If alcohol is used for cleaning, allow time for drying.



CAUTION: IF RFE assembly has been removed a recalibration is needed. Aalborg® offers professional calibration support. Contact your local distributor for cleaning and recalibration options.

Inspect the flow path inside the transducer for any visible signs of contaminant. If necessary, flush the flow path through with alcohol. Thoroughly dry the flow paths by flowing clean dry gas through.

Carefully re-install the RFE assembly and inlet fitting avoiding any twisting and deforming to the RFE. Be sure that no dust has collected on the O-ring seal.



CAUTION: OVER TIGHTENING WILL DEFORM AND RENDER THE RFE DEFECTIVE. IF RFE ASSEMBLY WAS NOT REMOVED, IT IS ADVISABLE THAT AT LEAST ONE CALIBRATION POINT BE CHECKED AFTER RE-INSTALLING THE INLET FITTING. SEE SECTION (8.2.3).

7.2.2 ZFM 37/47 Models

Unscrew the four socket head cap screws (two 10-24 and two 6-32) at the inlet side of the meter. This will release the short square block containing the inlet compression fitting.

The 60 micron filter screen will now become visible. Remove the screen. DO NOT remove the RFE inside the flow transducer. Clean or replace each of the removed parts as necessary. If alcohol is used for cleaning, allow time for drying. Inspect the flow path inside the transducer for any visible signs of contaminants.

If necessary, flush the flow path with alcohol. Thoroughly dry the flow paths by flowing clean dry gas through. Re-install the inlet parts and filter screen. Be sure that no dust has collected on the O-ring seal.

It is advisable that at least one calibration point be checked after re-installing the inlet fitting (see section 8).

8. CALIBRATION PROCEDURES



NOTE: REMOVAL OF THE FACTORY INSTALLED CALIBRATION SEALS AND/OR ANY ADJUSTMENTS MADE TO THE METER, AS DESCRIBED IN THIS SECTION, WILL VOID ANY CALIBRATION WARRANTY APPLICABLE.

ZFM is using “**Primary Calibration Table**” which was calibrated on the factory with Nitrogen and proprietary empiric K-Factors curves (individually developed by each model) to transfer calibration curve to the “**Main Gas Table**” according to desired full scale range and gas.



NOTE: ZFM “Primary Calibration Table” can be only calibrated by Aalborg® Instruments' Flow Calibration Laboratory or Aalborg® authorized trained and certified calibration facility.

ZFM flow meter has additional 10 **User Gas Tables [U1 - U10]** which can be directly calibrated by user with desired actual gas and full scale flow range (N2 equivalent maximum and minimum full scale flow limits for particular ZFM model have to be observed).

8.1 Flow Calibration

Aalborg® Instruments' Flow Calibration Laboratory offers professional calibration support for Mass Flow Meters using NIST traceable precision calibrators under strictly controlled conditions. NIST traceable calibrations are available. ZFM **User Gas Tables [U1 - U10]** calibrations can also be per-formed at customers' site using available standards.

Generally, calibrations are performed using dry nitrogen gas. The calibration can then be corrected to the appropriate gas desired based on relative correction [K] factors shown in the gas factor table (see APPENDIX II). A reference gas, other than nitrogen, may be used to better approximate the flow characteristics of certain gases. This practice is recommended when a reference gas is found with thermodynamic properties similar to the actual gas under consideration. The appropriate relative correction factor should be recalculated (see section 10).

It is standard practice to calibrate Mass Flow Meters with dry nitrogen gas at 70.0 °F (21.1 °C), 20 psia (137.9 kPa absolute) inlet pressure and 0 psig outlet pressure. It is best to calibrate ZFM transducers to actual operating conditions. Specific gas calibrations of non-toxic and non-corrosive gases are available for specific conditions. Please contact your distributor or Aalborg® for a price quotation.

It is recommended that a flow calibrator be used which has at least four times better collective accuracy than that of the Mass Flow Meter to be calibrated. Equipment required for calibration includes: a flow calibration standard, PC with available RS485/RS232 communication interface, a certified high sensitivity multi meter (for analog output calibration only), a flow regulator (for example - metering needle valve) installed upstream from the Mass Flow Meter, and a pressure regulated source of dry filtered nitrogen gas (or other suitable reference gas). Using Aalborg® supplied configuration and calibration software to simplify the calibration process is recommended.

Gas and ambient temperature, as well as inlet and outlet pressure conditions, should be set up in accordance with actual operating conditions.

8.2 "User Gas Table" Calibration of ZFM Mass Flow Meters



NOTE: All adjustments in this section are made from the outside of the meter via digital communication interface between a PC (terminal) and ZFM test/maintenance port. There is no need to disassemble any part of the instrument or perform internal PCB component (potentiometers) adjustment.

8.2.1 Connections and Initial Warm Up

Power up the Mass Flow Meter for at least 30 minutes prior to commencing the calibration procedure. Establish digital RS485/RS232 communication between PC (communication terminal) and the ZFM. Start Aalborg® supplied "ZFM Configuration Utility" software on the PC.

8.2.2 ZERO Check/Adjustment

The zero reading of each instrument is factory adjusted. However, the zero reading may shift slightly due to temperature, pressure, gas type and mounting position influences. If required, the zero flow calibration of the instrument may be performed.

If meter equipped with optional OLED/Joystick interface the Zero reading can be checked using PI screen #6 "Meter Diagnostic" (see example below).

Alternatively (for instruments without OLED/Joystick interface) it can be checked via digital communication interface using supplied “ZFM Configuration Utility” software (use Tools/Zero Adjustment menu selection).

PI Screen #6 (Meter Diagnostic)

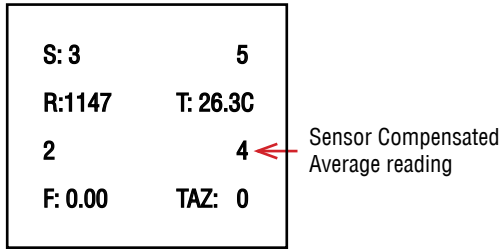

With no flow conditions, the Sensor Compensated Average reading must be in the range 0 ± 10 counts. If it is not, perform Auto Zero procedure.

Zero reading adjustment is possible over RS232/RS485 digital interface using supplied “ZFM Configuration Utility” software (see **Figure 8.1** below), optional local OLED/Joystick interface (see Paragraph 6.4.12) or by means of using multi-functional maintenance push button (see Paragraph 6.5).



Figure 8.1 Zero Control and Adjustment using “ZFM Configuration Utility” software.

8.2.3 User Gas Linearization Table Calibration /Adjustment



NOTE: Your ZFM Digital Mass Flow Meter was calibrated at the factory for the specified gas and full scale flow range (see device’s front label). There is no need to adjust the user gas linearization table unless linearity adjustment is needed, flow range has to be changed, or new additional calibration is required. Any alteration of the user gas linearization table will VOID calibration warranty supplied with instrument.

Gas flow calibration parameters are separately stored in the User Gas Dependent portion of the EEPROM memory for each of 10 calibration tables.



NOTE: Make sure the correct User Gas Table number is selected as currently active. All adjustments made to the gas linearization table will be applied to the currently selected User Gas Table. Use local OLED/Joystick interface (submenu "Select Gas Table", see paragraph 6.4.7) or a digital communication interface using supplied "ZFM Configuration Utility" software (Options/Device Properties menu selection) to verify current gas table or select a desired User Gas Table number.

The ZFM User Gas Linearization Table calibration involves building a table of the actual % full scale flow values (indexes 314, 316, 318, 320, 322, 324, 326, 328, 330, 332, 334) and corresponding sensor reading counts (indexes 313, 315, 317, 318, 319, 321, 323, 325, 327, 329, 331, 333).



NOTE: It is recommended to use Aalborg® supplied "ZFM Configuration Utility" software for gas table calibration. This software includes an automated calibration procedure which may radically simplify reading and writing for the EEPROM linearization table.

When user select software Tools/User Gas Table/Linearizer Calibration menu option the software will prompt with following warning:

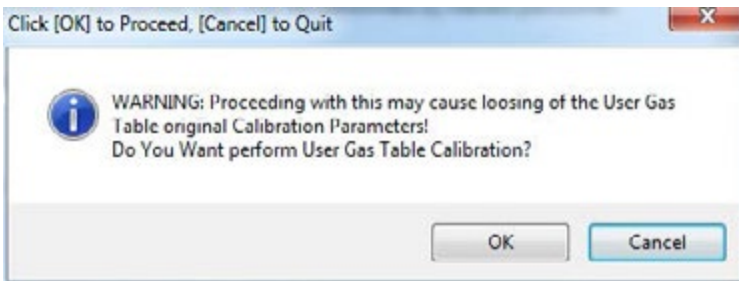

NOTE: By default (factory settings) after power is applied to the ZFM Main Gas Table #0 is active. If User Gas Table calibration is required user has to use menu Properties/Device Settings and select Current Gas Table option from the Device Parameters tree view panel.



NOTE: Before changing Current Gas Table number make sure ZFM was ordered from factory with valid calibration for corresponding Gas Table. By default, (unless customer ordered special calibration) the ZFM is shipped from factory only with one Primary Gas Table calibration scaled in to the Main Gas Table #0 according customer order. Selecting not calibrated User Gas Table may lead to unpredicted flow rate and flow meter behavior.

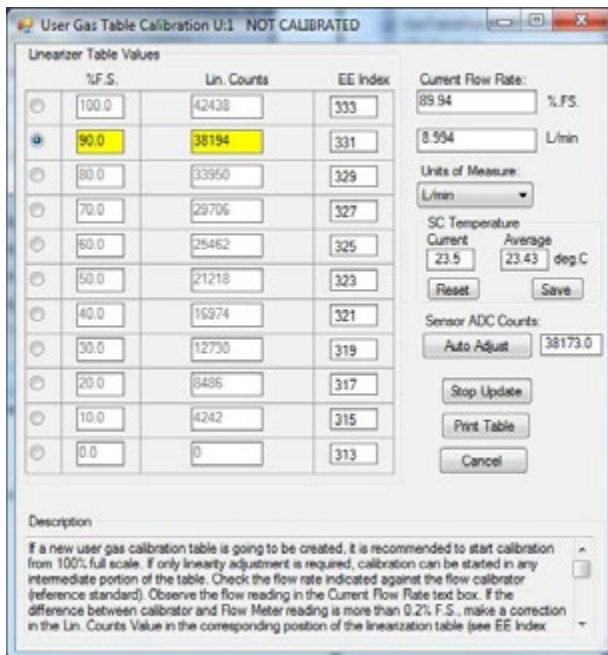

Figure 8.2 User Gas Table Calibration using "ZFM Configuration Utility" software.



NOTE: The currently selected User Gas Table number is displayed in the "User Gas Table Calibration" panel header. Before proceeding with calibration make sure you are calibrating right User Gas Table.

Sensor readings are entered in counts of 16 bits ADC output and should always be in the range of 0 to 60000. There are 11 elements in the table so the data should be obtained at an increment of 10.0 % of full scale (0.0, 10.0, 20.0, 30.0, 40.0, 50.0, 60.0, 70.0, 80.0, 90.0 and 100.0 % F.S.). If a new calibration table is going to be created, it is recommended to start calibration from 100% full scale. If only linearity adjustment is required, calibration can be started in any intermediate portion of the table. Adjust ZFM flow rate using installation needle valve. Check the flow rate indicated against the flow calibrator. Observe the flow reading in the Current Flow Rate text box. If the difference between calibrator and ZFM reading is more than 0.2% F.S., make a correction in the Lin. Counts Value in the corresponding position of the linearization table (e.g. see EE Index 331). If the ZFM flow reading is less than the calibrator reading, the Lin. Counts value in the index 331 must be decreased. If the ZFM flow reading is more than the calibrator reading, the Lin. Counts value in the index 331 must be increased. Once Index 331 is adjusted with a new value, check the ZFM flow rate against the calibrator and, if required, perform additional adjustments for Index 331. Once 100% set point is calibrated, you can proceed with 90% set point by selecting corresponding radio button and eventually continue down to 10% F.S. using procedure described above.



NOTE: For all calibration points (except 100.0 and 0.0% F.S.) Auto Adjust button may be used if difference between ZFM reading and corresponding Nominal %F.S. value is within +/- 2.0% of full scale. Once Auto Adjust button is enabled user can click it and software will adjust Lin Counts value in corresponding position to make ZFM reading equal to the calibration standard.



NOTE: Percent Full Scale values for 0.0 and 100.0 % F.S. can not be changed. Make sure the values entered in to the linearization table are monotonic (proportional). Once new value is typed in the text box, in order to upload it to EEPROM user should press "ENTER".



NOTE: ZFM flow meter uses temperature sensor embedded in to the sensor compartment for temperature compensation. In order to perform sensor temperature compensation properly the value of the sensor compartment average temperature during meter calibration has to be saved in to the User Gas Table EEPROM memory. It is recommended to save average sensor compartment temperature as soon as all 10 calibration points have been completed. Use "Save" button located in the "SC Temperature" group box to upload Average SC temperature to the meter EEPROM (see Figure 8.2).

9. MAIN GAS TABLE RECONFIGURATION (RESCALING)

ZFM flow meter supports multi-gas/multi-range functionality which allow users save time and money by on site rescaling the instruments to the desired gas and full scale range based on minimum and maximum supported full scale ranges (see Table 4.1) for given model number (currently following gases are supported: N2, Air, O2, Argon, Helium, CO2).

ZFM is using "Primary Calibration Table" which was calibrated on the factory with Nitrogen and proprietary empiric K-Factors curves (individually developed by each model) to transfer calibration curve to the "Main Gas Table" according to desired full scale range and gas. Main Gas Calibration Table [MO] usually configured on the factory for flowing fluid and full scale range according to customer order. It can be reconfigured by user to desired flow range and supported gas using supplied "ZFM Configuration Utility" software Tools/Main Gas Table Reconfiguration / Rescaling procedure.

In order to rescale **Main Gas Table** select "Tools" menu and scroll down to **Main Gas Table Rescaling** menu selection. The software will prompt with following warning:

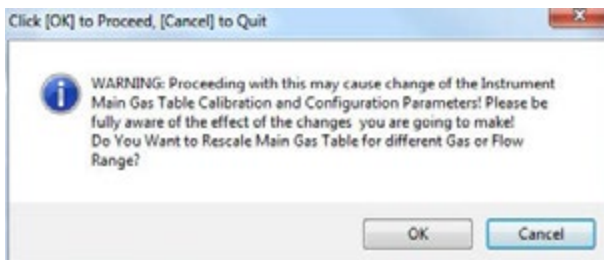

In order to proceed with rescaling user should click "OK" button. **Main Gas Table Rescaling** window will be opened (see **Figure 9.1**).

On the top of the Rescaling screen shown meter identification parameters:

- Instrument Model
- Instrument Serial Number
- Nominal N2 Full Scale Range
- RFE Style and Configuration

These parameters are read only and cannot be changed by user.

Current **Main Gas Table** configuration shown below. User should pay attention to two important parameters: **Customer Selected Full Scale Range** and **Customer Selected Fluid Name**.

Current Main Gas Table Settings		
Customer Selected Fluid Name:	NITROGEN	Index[0]
Customer Selected Full Scale Range:	0.800000	sl/min
Customer Selected STD Temperature:	70.000000	F
Customer Selected STD Pressure:	14.700000	PSIA
Customer Selected Fluid STD Density:	1.163750	g/ltr
Instrument Rescaled By:	AB	
Instrument Rescaling Date:	05-DEC-14	
Main Gas Table Rescaling Counter:	1	

Figure 9.1 Main Gas Table Rescaling using "ZFM Configuration Utility" software

In order to Rescale **Main Gas Table** user should select new Fluid Name from dropped down menu box named "Fluid Set by Customer". Once new Fluid Name selected the Minimum and Maximum limits for full scale range will be updated and user may type in new desired full scale range value in to the "Full Scale Range" text box. See example below (**Figure 9.2**) for new Fluid Name: Argon and new Full Scale range 1.0 sl/min.



NOTE: New Full Scale Range value should be within minimum and maximum full scale flow ranges shown on the left side of the window.

Main Gas Table Rescaling

Instrument Model:

Instrument Serial Number: RFE Style: 3

Nominal N2 Full Scale Range sl/min RFE Configuration: 8

Current Main Gas Table Settings

Customer Selected Fluid Name:	NITROGEN	Index[0]
Customer Selected Full Scale Range:	0.800000	sl/min
Customer Selected STD Temperature:	70.000000	F
Customer Selected STD Pressure:	14.700000	PSIA
Customer Selected Fluid STD Density:	1.163750	g/ltr
Instrument Rescaled By:	AB	
Instrument Rescaling Date:	05-DEC-14	
Main Gas Table Rescaling Counter:	1	

New Rescaled Main Gas Table Fluid and Full Scale Range

Fluid Set by Customer: Argon Full Scale Range: sl/min

Minimum Full Scale Range: sl/min Rescaled By:

Maximum Full Scale Range:

Figure 9.2 Main Gas Table Rescaling using "ZFM Configuration Utility" software: Selecting new Fluid and Full Scale Range.

In order to perform actual rescaling user should click on "Rescale" button. After confirmation window shown below the software will perform check of all required parameters and build new calibration curve.



NOTE: In order to proceed with rescaling procedure user should enter user ID (for example initials: e.g. "TS") in to the "Rescaled By" text box field.

Click [OK] to Proceed, [Cancel] to Return Back

You have selected rescaling instrument MGT to 1.0 sl/min of Argon. Do You Want to perform Rescaling procedure based on these settings?

Once rescaling is completed new calibration curve (Red color) will be shown together with "Primary Calibration Curve" (Green color). In order to finish rescaling process user should click on "Upload" button (see **Figure 9.3**). New **Main Gas Table** will be uploaded in to the meter EEPROM.



Figure 9.3 Main Gas Table Rescaling using "ZFM Configuration Utility" software: Uploading new MGT to the EEPROM.

Once new Main Gas Table is uploaded in to the meter EEPROM the confirmation message will appear:



10. RS485/RS232 SOFTWARE INTERFACE COMMANDS

10.1 General

The standard ZFM comes with an RS232 interface (RS485 interface is optional). For the RS232 interface, the start character (!) and two hexadecimal characters for the address must be omitted. The protocol described below allows for communications with the unit using either a custom software program or a “dumb terminal.” All values are sent as printable ASCII characters. For RS485 interface, the start character is always (!). The command string is terminated with a carriage return (line feeds are automatically stripped out by the ZFM). See Paragraph 3.3 for information regarding communication parameters and cable connections.

10.2 Commands Structure

The structure of the command string:

RS485	!<Addr>,<Cmd>,Arg1,Arg2,Arg3,Arg4<CR>	Example: !11,F<CR>
RS232	<Cmd>,Arg1,Arg2,Arg3,Arg4<CR>	Example: F<CR>

Where:

!	Start character ** (must be only used for RS485 option)
Addr	RS485 device address in the ASCII representation of hexadecimal (00 through FF are valid). ** (must be only used for RS485 option)
Cmd	The one or two character command from the table below.
Arg1 to Arg4	The command arguments from the table below. Multiple arguments are comma delimited.
CR	Carriage Return character.



NOTE: Default RS485 address for all units is 11. Do not submit start character and two character hexadecimal device address for RS232 option.

Several examples of commands follow. All assume that the ZFM has been configured for decimal address 18 (12 hex) on the RS485 bus:

- To get current calibration tables: !12,G<CR>
The ZFM will reply: !12,G 0 AIR<CR> > (Assuming
Current Gas table is #0 (Main Gas Table), calibrated for AIR)
- To get current Alarm status: !12,AR:N<CR> (Assuming no alarm conditions)
- To get a flow reading: !12,F<CR>The ZFM will reply:
!12,50.0<CR> (Assuming the flow is at 50% FS)
- Set the flow High and Low Alarm limit to 90% and 10% of full scale flow rate:
!12,A,C,90.0,10.0<CR> The ZFM
will reply: !12, AC:90.00,10.00<CR>



NOTE: Address 00 is reserved for global addressing. Do not assign, the global address for any device. When command with global address is sent, all devices on the RS485 bus execute the command but do not reply with an acknowledge message.

The global address can be used to change RS485 address for a particular device with unknown address:

1. Make sure only one device (which address must be changed) is connected to the RS485 network.
2. Type the memory write command with global address: !00,MW,118,XX[CR] where XX, the new hexadecimal address, can be [01 – FF].

After assigning the new address, a device will accept commands with the new address.



NOTE: Do not assign the same RS485 address for two or more devices on the same RS485 bus. If two or more devices with the same address are connected to the one RS485 network, a communication collision will take place on the bus and communication errors will occur.

AALBORG ZFM ASC11
SOFTWARE INTERFACE COMMANDS (REV. A1 01/07/2015)

Note: An “*” indicates power up default settings.
 An “**” indicates optional feature not available on all models.

COMMAND NAME	DESCRIPTION	No.	COMMAND SYNTAX					Response
			Command	Argument 1	Argument 2	Argument 3	Argument 4	
Flow	Requests the current flow reading in current EU	1	F					<Value> (Actual flow in current engineering units)
Process Information (PI)	Read Process Information (PI) Variable: Flow Rate (current EU) Totalizer#1 value (current EU) Totalizer#2 value (current EU) Flow Alarm Status [D.N.H.L] Current status of the Alarm Events Register (Hex) Current status of Diagnostic Events Register (Hex) NOTE: See list of the Alarm and Diagnostic Events below.	2	PI	NO ARGUMENT (read only)				<Flow Value>, <Totalizer#1 Value>, <Totalizer#2 Value>, <Flow Alarm Status>, <Alarm Events Register>, <Diagnostic Events Register> Example: 25.4,354.2,248.9,N,0x1, 0x0
Alarm Events Registers	Read/Set/Reset value of Alarm Events Registers: Status Register: (Read/Reset) Mask Register: (R/W) Latch Register: (R/W) See list of the Alarm Events below: 0 FLOW_ALARM_HIGH 0x0001 1 FLOW_ALARM_LOW 0x0002 2 ALARM_RANGE 0x0004 3 TOTAL_HIT_LIMIT 0x0008 4 TOTAL2_HIT_LIMIT 0x0010 5 PULSE_OUT_QUEUE 0x0020 6 FLOW_ABOVE_LIMIT 0x0040 7 PASSWORD_EVENT 0x0080 8 POWER_ON_EVENT 0x0100	3	AE	NO ARGUMENT (read Alarm Events status register)				AE:<Value> Example: AE:0x0
				R - (reset Alarm Events status register to 0x0000)				AER:0x0
				M - (Read/Set Alarm Events Mask register)	NO ARGUMENT (read current settings)			AEM:0x1
				<Value> 0x0000-0x0FFF Set new value NOTE: all 6 characters are required				AEM:0x11

COMMAND SYNTAX								
COMMAND NAME	DESCRIPTION	No.	Command	Argument 1	Argument 2	Argument 3	Argument 4	Response
				L (Read/Set Alarm Events Latch register)	NO ARGUMENT (read current settings)			AEL:0x1
					<Value> 0x0000-0x0FFF Set new value NOTE: all 6 characters are required			AEL:0x11
Diagnostic Events Registers	Read/Set/Reset current value of the Diagnostic Events Registers Status Register: (Read/Reset) Mask Register: (R/W) Latch Register: (R/W) See list of the Diagnostic Events below: 0 CPU_TEMP_HIGH 0x0001 1 SC_TEMP_HIGH 0x0002 2 HEAT_OUT_OF_RANGE 0x0004 3 SRES_OUT_OF_RANGE 0x0008 4 VREF_OUT_OF_RANGE 0x0010 5 ANALOG_OUT_ALARM 0x0020 6 SER_COMM_FAILURE 0x0040 7 MB_COMM_FAILURE 0x0080 8 EEPROM_FAILURE 0x0100 9 AUTOZERO_FAILURE 0x0200 A FATAL_ERROR 0x0400	4	DE	NO ARGUMENT (read Diagnostic Events status register)				DE:<Value> Example: DE:0x0
				R (reset Diagnostic Events status register to 0x0000)				DER:0x0
				M - (Read/Set Diagnostic Events Mask register)	NO ARGUMENT (read current settings)			DEM:0x1
					<Value> 0x0000-0x0FFF Set new value NOTE: all 6 characters are required			DEM:0x101
				L (Read/Set Diagnostic Events Latch register)	NO ARGUMENT (read current settings)			DEL:0x1
					<Value> 0x0000-0x0FFF Set new value NOTE: all 6 characters are required			DEL:0x101

COMMAND SYNTAX							
COMMAND NAME	DESCRIPTION	No.	COMMAND SYNTAX			Response	
			Command	Argument 1	Argument 2		Argument 3
Gas Table	Read / Select Active Gas Table Gas Table Indexes: 5 P – Primary Gas Table (factory calibrated, always Nitrogen). No user access. 0 – Main Gas Table (reconfigurable by user for any supported gas using supplied PC software). [1-10] - User Gas Tables (may be recalibrated by user for any desired gas).	5	G	NO ARGUMENT (read current active Gas Table index and Gas Name) <Value> [0-10] Select new Gas Table. NOTE: Primary Calibration Table cannot be selected!			Example: G:0,NITROGEN 0 – Gas Table Index (Main Gas Table) NITROGEN – Gas name
Device Info	Read device configuration info: - current Gas Table (number/name) - full scale range (L/min) - current Units of Measure - K-Factor (mode/value): 0 – Disabled (1.0) 1 – Internal Index [0-26] 2 – User Defined (x.xxxx) - Analog Output Mode 0 – 0-5 Vdc 1 – 0-10 Vdc 2 – 4-20 mA - ModBus H/V status [0/1] 0 – Installed 1 – Not Installed	6	DI	NO ARGUMENT (read only)			DI:0,NITROGEN, 0.8000,ml/min,0,1.0000,0,0 0 – Gas Table M0 (N2) 0.800 – full scale (L/min) ml/min – current EU 0 – K-Factor (disabled, 1.0000) 0 – Analog Output set to 0-5 Vdc 0 – ModBus interface H/W installed (supported)

COMMAND SYNTAX								
COMMAND NAME	DESCRIPTION	No.	Command	Argument 1	Argument 2	Argument 3	Argument 4	Response
Flow Alarms	<p>Sets / reads the parameters of the flow alarms.</p> <p>Note: High alarm value has to be more than Low alarm value.</p> <p>Meter Alarm conditions:</p> <p>Flow \geq High Limit = H Flow \leq Low Limit = L Low < Flow < High = N</p> <p>Alarm Settings Reply parameters: M – mode (E/D) Hv – High settings value Lv – Low settings value A – Action Delay (sec) L – Latch mode (0-1) P – Power Up delay (sec)</p>	7	A	C (set Flow Alarm High and Low limits parameters)	<Value> (high limit, %F.S.) [0.1 – 110.0] F.S.	<Value> (low limit, %F.S.) [0.0 – 109.9] %F.S.		AC:40.10,20.50
				A (Flow Alarm action delay in sec.)	<Value> [0-3600]			AA:<Value> Example: AA:5
				E (enable alarm)				A:E
				D (disable alarm)*				A:D
				R (read current status)				AR:N (no alarm) AR:H (high alarm) AR:L (low alarm)
				S (Read current settings)				AS:M,Hv,Lv,A,L,P Example: AS:E,40.00,20.00,2,0,10
				P (Flow Alarm Power Up delay in sec.)	<Value> [0-3600]			AP:<Value> Example: AP:60
				L (Latch mode)	<Value> (0-disabled*) (1-enabled)			AL:<Value> where: Value = 0 – 1 Example: AL:0

COMMAND SYNTAX								
COMMAND NAME	DESCRIPTION	No.	COMMAND SYNTAX					
			Command	Argument 1	Argument 2	Argument 3	Argument 4	Response
Relay Assignment	Read / Set SSR Relay Assignment D - no action (SSR disabled*) AL - Low flow alarm AH - High flow alarm AR - Range between High & Low alarms T1 - Tot#1 reading > limit T2 - Tot#2 reading > limit PO - Pulse Output AE - Alarm Events DE - Diagnostic Events M - Manual On (energized) NOTE: when SSR is energized the normally open contact closure leads are connected.	8	R	D* AL AH AR T1 T2 PO AE DE M S (read current settings)				R:D R:AL R:AH R:AR R:T1 R:T2 R:PO R:AE R:DE R:M R:D
Analog Output	Sets / Reads Meter Analog Output settings and alarm status. Device Analog Output mode: Settings: 0 – 0-5 Vdc 1 – 0-10 Vdc 2 – 4-20 mA Device Analog Output alarm status: N – No Alarm (normal operation) Y – Alarm is On (abnormal conditions are detected)	9	AO	M	No Argument (Returns Current Analog Output mode settings) <Value>[0-2] Set new Analog Output mode settings			AOM:<Value> Example: AOM:0 AOM:<Value> Example: AOM:1 AOS:N

COMMAND SYNTAX									
COMMAND NAME	DESCRIPTION	No.	Command	Argument 1	Argument 2	Argument 3	Argument 4	Response	
Totalizers	Sets and controls action of the flow Totalizers. NOTE: Start totalizer at Flow value has to be entered in %FS (0.0 – 100.0) Limit volume has to be entered in currently selected EU If Totalizer hit limit event is not required, set "Limit Volume" value (argument 4) to zero. Totalizes support Count Up mode only. If Auto Reset mode is Enabled the Totalizer volume will be reset to zero as soon as Totalizer reading reaches "Limit Volume" value. Totalizers reading are stored in EEPROM (non volatile) memory. Power cycle will not affect Totalizers reading. In addition Totalizers reading are backed up in separate EEPROM partition with 6 minutes interval. In case of error Totalizers reading may be restored from backup location. Totalizers cannot be reset; if Reset Lock parameter value set to 1.	10	T	1 (Totalizer #1)	Z (Reset to zero)			T1Z or T2Z	
				2 (Totalizer #2)	C – Start flow and Event Condition	<value> (start totalizer at flow) %FS [0.0 – 100.0]	<value> (Limit volume in current volume based EU)		T1C:2.5, 0.0 (limit not required) or T2C:2.0,20580.5
					P – Power On Delay	<value> [0-3600 sec.]			T1P:10 or T2P:20
					D - (disable totalizer)*				T1:D or T2:D
					E - (enable totalizer)				T1:E or T2:E
					R (read current totalizer volume reading)				T1R:<value> or T2R:<value> (in current EU)
					S (read current settings status)				T1S:Mode, tartFlow,LimitVolume, PowOnDelay, AutoResetMode, AutoResetDelay Example: T1S:E,0.5, 2045.2;T1:0,0.5
					A Set Auto Reset mode	<value> [0-1] 0 – Disable 1 – Enable			T1A:0 - disabled Or T2A:1 - enabled
					I Set Auto Reset Interval delay	<value> [0-3600 sec.]			T1I:2 Or T2:I:0
					B Restore Totalizer value from EE backup				T1B or T2B
	L Totalizer Lock status read / set	No Argument (read Lock status) <value> [0-1] Set Lock mode 0 – Unlock 1 – Lock			T1L:0 or T2L:0 T1L:1 or T2L:1				

COMMAND SYNTAX								
COMMAND NAME	DESCRIPTION	No.	Command	Argument 1	Argument 2	Argument 3	Argument 4	Response
Pulse Output	<p>Sets and controls action of the programmable Pulse Output circuitry.</p> <p>NOTE: Unit/Pulse value has to be entered in currently selected EU. EU has to be not time based It is recommended to set the unit/pulse value equal to the meter maximum flow in the same units per second equivalent. This will limit the pulse to no faster than one pulse every second.</p> <p>Example: Maximum flow rate: 600 liter/min (600 liter/min = 10 liters per second) If Unit/Pulse is set to 10 liters per pulse, the output will pulse once every second (F=1 Hz). Pulse active time in ms has to be at least twice less than pulse period (1/F). In this example any value between 50 and 500 ms will be acceptable.</p>	11	P	U Set Units Per Pulse Parameter.	<Value> (Unit/Pulse) In current E.U. (example: 10 liter/pulse)			PU:<value> Example: PU:10
			T	Set Pulse active Time in ms	<value> [50 -6553 ms]			PT:<value> Example: PT:100
			D	(disable pulse output)*				P:D
			E	(enable pulse output)				P:E
			Q	(read current pulse output Queue value)				PQ:<value> (number of pulses in Queue)
			F	Set Flow Start value	<value> (0.0-100.0%FS)			PF:1.0
			S	(read setting status)				PS:Mode,FlowStart,Unit/ Pulse,PulseTimeInterval Example: PS:E,1.0,1.666,100
Status LED	<p>Read and set current Status LED mode:</p> <ul style="list-style-type: none"> 0 – Normal 1 – F-Alarm & Totalizers only 2 – Alarm Events only 3 – Diagnostic Events 4 – UART interface events 5 – ModBus interface events 	12	S	No Argument (Returns Current Status LED mode)				S:<mode value> Example: S:0
				<mode value> [0-5] Set new Status LED mode value				S:< mode value > Example: S:1

COMMAND SYNTAX								
COMMAND NAME	DESCRIPTION	No.	Command	Argument 1	Argument 2	Argument 3	Argument 4	Response
Units of measure	<p>Set units of measure for flow rate and totalizer reading.</p> <p>Note: The units of the totalizer output are not per unit time.</p> <p>For user defined units: k-Factor value represents conversion value from L/min. Time base argument: 0 - seconds 1 - minutes 2 - hours 3- days</p> <p>Density argument: 1 - use density 0 - do not use density</p> <p>lg1 - Imperial Gal MnL - million liters bbl - Barrels</p>	13	U	%FS* ml/sec ml/min ml/hr ml/day l/sec l/min l/hr l/day m ³ /sec m ³ /min m ³ /hr m ³ /day f ³ /sec f ³ /min f ³ /hr f ³ /day gal/sec gal/min gal/hr gal/day gr/sec gr/min gr/hr gr/day kg/sec kg/min kg/hr kg/day lb/sec lb/min lb/hr lb/day				U: % U: mL/sec U: mL/min U: mL/hr U: mL/day U: L/sec U: L/min U: L/hr U: L/day U: m ³ /sec U: m ³ /min U: m ³ /hr U: m ³ /day U: f ³ /sec U: f ³ /min U: f ³ /hr U: f ³ /day U: gal/sec U: gal/min U: gal/hr U: gal/day U: gr/sec U: gr/min U: gr/hr U: gr/day U: kg/sec U: kg/min U: kg/hr U: kg/day U: lb/sec U: lb/min U: lb/hr U: lb/day

COMMAND NAME	DESCRIPTION	No.	COMMAND SYNTAX						
			Command	Argument 1	Argument 2	Argument 3	Argument 4	Response	
				ton/min					U: ton/min
				ton/hr					U: ton/hr
				lgl/sec					U: lgl/sec
				lgl /min					U: lgl/min
				lgl /hr					U: lgl/hr
				lgl/day					U: lgl/day
				MnL/min					U: MnL/min
				MnL/hr					U: MnL/hr
				MnL/day					U: MnL/day
				bb/sec					U: bb/sec
				bb/min					U: bb/min
				bb/hr					U: bb/hr
				bb/day					U: bb/day
				USER (user defined)	No Argument Set previously defined USER unit				
				USER (user defined) Change parameters of the user defined unit	<k-factor value> [>0.0]	<Time Base> 0-second 1-Minute 2-Hour 3-Day	<Use Density> [0 or 1] 0 – No 1 – Yes		U:user K-Factor TimeBase,UseDensity Example: U:USER,1.5,1,0
				No Argument (status)					U:<EU name> Example: U:mL/min

COMMAND SYNTAX								
COMMAND NAME	DESCRIPTION	No.	Command	Argument 1	Argument 2	Argument 3	Argument 4	Response
K-Factor	Read and set K-Factor relative to N2 Mode: D – Disabled (K-Factor = 1.0) I – Internal U – User Defined Internal KF Index values: [1-26] User Defined K-Factor and fluid Density @ STD values must be more than zero. STD conditions for Density: 21.1 C and 14.7 PSIA NOTE: “N2 Roll Back” feature is only applicable for User Defined Gas Tables	N2 14	K	S (read current settings) Returns current mode, index and UD values D (Set Mode: Disabled) I (Set Mode: Internal Index) U (Set Mode: User Defined KF and Density Values)	(read current settings) Returns current mode, index and UD values No Argument. Set Internal K-Factor mode <Index>[1-26] Set new internal index No Argument Set user defined K-Factor mode <Value> [0.00001-999.9] Set new UD KF value			KS:Mode,Index,UD,valueK, UD,valueD Example: KS:U,1,0.91200,1,16 KD KI:Index,GasName Example: KI:1,Ar KI:Index,GasName Example: KI:5,C2H2 KU:KFVal, DensityVal Example: KU:0.8750, 1.48 KU:KF-Val,Density-Val Example: KU:0.91200,1,16
Calibration Settings	Sets/Reads Calibration related variables. NOTE: Density @ STD conditions valid values: 0.00001- 999.9 gr/liter Hours since last time unit was calibrated. NOTE: has to be reset to zero after calibration.	15	C	D User Gas Table Fluid Density @ STD conditions (valid only for Gas Tables 1-10) T Read/Reset Meter main Calibration /Maintenance Timer	<Value> [gr/liter] No Argument (Returns Current Density value) No Argument (read timer) Z Reset Timer to Zero			KN:Value Example: KN:D KN:Value Example: KN:D CD:<value> Example: CD:1.256 CD:<value> Example: CD:1.256 CT:<value> Example: CT:1024.2 CT:Z

COMMAND SYNTAX								
COMMAND NAME	DESCRIPTION	No.	Command	Argument 1	Argument 2	Argument 3	Argument 4	Response
Signal Conditioner Settings	Sets/Reads meter Signal Conditioner Parameters NOTE: The signal conditioner parameters were set on the factory to keep best performance. Do not change Signal Conditioner parameters unless instructed by factory technical support representative! NOTE: NLES parameter a1 must be more than a0. Similar NLES parameter D1 must be more than D0.	16	SC	M Read/Change Device PI Signal Conditioner NLES mode E – Enabled* D – Disabled (No Conditioning) R Flow Running Average Damping [1-255] samples 1 – Disabled* A Sensor Compensated signal conditioning NLES A0 and A1 parameters (do not change factory default settings unless instructed by tech support) Z Read/Change Device Auto Zero sensor reading NLES mode E – Enabled* D – Disabled (No Conditioning) C Read/Change Device Signal Conditioner DRC mode 0 – Disabled (No DRC) 1 – Only for rising flow 2 – Both for rising and falling flow* D Sensor Compensated signal conditioning NLES D0 and D1 parameters (do not change factory default settings unless instructed by tech support)	<New Mode> [E/D] No Argument (Returns current Mode) <new value> [1-255] No Argument (Returns current setting value) <a0_value> [0.01 - 0.99] No Argument (Returns Current settings values) <New Mode> [E/D] No Argument (Returns current Mode) No Argument (Returns Current settings values) <New Mode> [0-2] <D0_value> [0.01 - 0.99] No Argument (Returns Current settings values)			SCM:<value> Example: SCM:D SCM:<value> Example: SCM:E SCR:<value> Example: SCR:4 SCR:<value> Example: SCR:1 Example: SCA:0.20,0.80 Example: SCA:0.20,0.80 SCZ:<value> Example: SCZ:D SCZ:<value> Example: SCZ:E Example: SCC:2 Example: SCC:2 SCD:<value> Example: SCD:0.20,0.80 SCD:<value> Example: SCD:0.20,0.80

COMMAND SYNTAX								
COMMAND NAME	DESCRIPTION	No.	Command	Argument 1	Argument 2	Argument 3	Argument 4	Response
OLED and Process Screens Settings**	Sets/Reads OLED related parameters**. Argument 1 = S Process Screens Mask register: 0x00FF – screen mask (8 bits wide). Set bit - Enable Screen Clear bit - Disable Screen See list of the Process Screens below: 0x01 – Flow Rate / Totalizer#1 0x02 – Flow Rate / Totalizer#2 0x04 – Flow Rate, Tot#1, Tot#2 0x08 – Meter Configuration Info 0x10 – Meter Status Info 0x20 – Meter Troubleshooting NOTE: Screen #1 (0x01) cannot be disabled. “L” command without any arguments will return OLED status: Y – Display installed N – Display is not installed When Argument #2 is not submitted command returns current settings.	17	L	M LOD Process Screen Mode: S - Static D - Dynamic C OLED Screen Saver Brightness Level: [1-128] B - OLED operational Brightness Level: [1-255] O - OLED Screen Saver Time Delay before activation: [1-36000] seconds P - OLED Screen Saver Mode 0 – Screen Saver Disabled 1 – Low Brightness mode 2 – Vertical Scrolling mode 3 – OLED off T OLED Process Screen Time Interval in sec. (for dynamic mode) S OLED Process Screens Mask register D OLED Flow Reading decimal point precision: 0 - Normal 1 – Elevated (+1)	<New Value> S or D No Argument (Returns Current settings) <new value> [1-128] No Argument <new value> [1-255] No Argument <new value> [1-36000] No Argument <new mode> [0 - 3] No Argument (Returns Current settings) <New Value> [1-3600] No Argument No Argument (Returns Current settings) <Value> 0x0001-0x003F (all 6 characters are required) <new value> [0-1] No Argument (Returns Current settings)			LM:<value> Example: LM:S LM:<value> Example: LM:S LC:<value> Example: LC:6 LC:<value> Example: LC:6 LB:<value> Example: LB:127 LB:<value> Examp.: LB:127 LO:<value> Example: LO:900 LO:<value> Ex.: LO:900 LP:<value> Example: LP:2 LP:<value> Example: LP:2 LT:<value> Example LT:5 LT:<value> Example: T:5 Example: LS:0x03 (only first two screens are enabled: 0x01 and 0x02) Example: LS:0x3F (all 6 screens are enabled) LD:<value> Example LD:1 LD:<value> Example LD:1

COMMAND NAME	DESCRIPTION	No.	COMMAND SYNTAX						
			Command	Argument 1	Argument 2	Argument 3	Argument 4	Response	
Auto Zero	<p>Sets/Reads Meter Auto Zero related parameters</p> <p>CAUTION: make sure absolutely no flow through the meter during Sensor Zero offset calibration!</p> <p>NOTE: For proper result meter has to be connected to power for at least 30 minutes prior to Auto Zero calibration.</p> <p>Auto Zero Status return parameters: <DP value> - Current DP value <ADC value> - Current ADC value AZ Status:</p> <p>N – Auto Zero Not Started I – Auto Zero In Process F – Auto Zero Failed D – Auto Zero is Done (Success)</p> <p>NOTE: The DTDAZ parameters were set on the factory individually for each sensor to keep best temperature compensation performance. Do not change DTDAZ parameters unless instructed by factory technical support representative!</p> <p>NOTE: Z,W command saves current sensor compartment temperature. Do not execute Z,W command unless Auto Zero procedure (Z,N command) was done successfully (Z,S command returned D status)!</p>	18							
			V - Display current Zero control DP Value	No Argument				ZV <DP Value> Example: ZV:589	
			N - Start Sensor Auto Zero calibration now. NOTE: make sure absolutely no flow through the meter!	No Argument				ZN - NOTE: For proper result meter has to be connected to power for at least 30 minutes prior to Auto Zero calibration	
			S - Display Auto Zero Status					ZS: <DP value>,<ADC value>,<AZ Status> Ex: ZS:721.2,N	
			T - Auto Zero acceptable tolerance (ADC counts) Note: Factory default value is 7.	No Argument (Returns Current settings)				ZT: <value> Example: ZT:7	
			D Dynamic Temperature Dependent Auto Zero (DTDZAZ) parameters settings	<New Value> [5 - 255]				ZT: <value> Example: ZT:7	
			M DTDZAZ Mode E - Enabled * D - Disabled		No Argument (Return Current settings)			ZDM: <mode> Example: ZDM:E	
			T DTDZAZ Temperature Difference threshold [0-20 °C]		No Argument (Return Current settings)			ZDT: <value> Example: ZDT:1.0	
			C DTDZAZ Temp dependent Zero Drift Coefficient [ADC counts/°C]		<New Value> [0-20 °C]			ZDT: <value> Example: ZDT:1.0	
			Do not change the value of the DTDZAZ Temp dependent Zero Drift Coefficient parameter unless instructed by factory technical support representative!		No Argument (Return Current settings)			ZDC: <value> Example: ZDC:2.081	
			Do not change the value of the DTDZAZ Temp dependent Zero Drift Coefficient parameter unless instructed by factory technical support representative!		<New Value> [-50.0 – 50.0]			ZDC: <value> Example: ZDC:2.081	
			R - DTDZAZ Sensor ADC output change per one DP count adjustment ratio		No Argument (Return Current settings)			ZDR: <value> Example: ZDR:13.0	
			W Save DP and Sensor Compartment Temperature		<New Value> [0.1 – 99.9]			ZDR: <value> Example: ZDR:13.0	
				No Argument				ZW	

COMMAND SYNTAX								
COMMAND NAME	DESCRIPTION	No.	Command	Argument 1	Argument 2	Argument 3	Argument 4	Response
Sensor ADC Span Temperature Compensation	Sets/Reads Sensor ADC Span Temperature Compensation Parameters CAUTION: The meter Sensor ADC Span Temperature Compensation Parameters were set on the factory to keep best performance. Do not change Temperature Compensation parameters unless instructed by factory technical support representative!	19	TC	M - Read/Change Sensor ADC Span Temperature Compensation Mode E- Enabled D- Disabled S Reads current Status of the Sensor ADC Span Temperature Compensation Parameters T Read/Change Sensor ADC Span Temperature Compensation activation Threshold value [°C] Factory default value 1.0 °C. A Read/Change Sensor ADC Span Temperature Compensation ADC counts Threshold Factory default value:36569 counts C Read/Change Sensor ADC Span Temperature Compensation Correction Threshold value [°C] Factory default value 2.5 °C P Sensor ADC Temperature Compensation base polynomial parameters: a, b, c Factory default*: 0.00000002,0.0011,0.4295 Q Sensor ADC Temperature Compensation correction polynomial parameters: a, b, c Factory default*: 0.00000003,0.0008,1.1611	<New Value>E or D No Argument (Return Current settings) No Argument (Return Current settings) <Value> [0.0-25.0 °C] No Argument (Return Current settings) No Argument (Return Current settings) <Value> [0.0-50000.0] No Argument (Return Current settings) <Value> [0.0-25.0 °C] No Argument (Return Current settings) <Value A> No Argument (Return Current settings) <Value A>			TCM:<value>Example: TCM:E TCM:<value> Example: TCM:E TCS:M,T,CST,CALT,K Example: TCS:E:1.0,26.1,26.5,0 Where: M – TC Mode [E/D] T – TC Threshold [°C] CST – Sens. Comp. Temp [°C] CALT – Sens. Comp. Temp during last calibration [°C] K – Calculated Span Temp Compensation Correction val. TCT:<value>Example: TCT:2.0 TCT:<value> Example: TCT:2.0 TCA:<value> Example: TCA:39256.0 TCA:<value> Example: TCA:39256.0 TCC:<value> Example: TCC:2.5 TCC:<value> Example: TCC:2.5 TCP:<val A><val B><val C> Example: TCP:0.00000002,0.0011,0.4295 TCP:0.00000002,0.0011,0.4295 TCQ:<val A><val B><val C> Example: TCP:0.00000003,0.0008,1.161 Example: TCP:0.00000003,0.0008,1.161

COMMAND NAME	DESCRIPTION	No.	COMMAND SYNTAX				
			Command	Argument 1	Argument 2	Argument 3	Argument 4
ModBus ** Communication settings and address (optional)	Sets/Reads meter ModBus Communication settings and address (optional)** Diagnostic Command (argument D) returns following parameters: MsgCtr – Message Counter SRSErrCtr – CRC Error Counter SlaveMsgCtr – Slave Message Counter ORErrCtr – Overrun Error Counter	20	B ModBus interface baud rate parameter: 1200,2400,4800,9600* , 19200,38400,57600,115200 P – ModBus interface Parity: 0 – None* 1 – ODD 2 – EVEN S ModBus interface Stop Bits: [1 or 2*] A ModBus slave device address: [1-247] Factory default address:11 D Diagnostic of ModBus state machine communication counters R - Reset ModBus communication Port and ModBus state machine. 0 to 285 (EEPROM Memory Table Index)	No Argument (Return Current settings) <Baud Rate Value > No Argument (Return Current settings) <Parity Value > No Argument (Return Current settings) <Stop Bit Value> No Argument (Return Current settings) <AddressValue> No Argument (Return Current settings) No Argument (Reports command receiving)			MBS:<Baud Rate Value> Example:MBS:9600 MBS:9600 MBP:<Parity Value> Example:MBP:0 MBP:0 MBS:<Stop Bits Value> Example:MBS:2 MBS:2 MBA:<Address Value> Example:MBA:11 MBA:11 MBD: MsgCtr, SRSErrCtr, SlaveMsgCtr,ORErrCtr Example: MBD:1,0,0,0 MBR:Done <memory value>
Read EEPROM Memory	Reads the value in the specified EEPROM memory location	21	MR				
Write EEPROM Memory	Writes the specified value to the specified memory location. CAUTION: Use Carefully, can cause unit to malfunction. (Note: Some addresses are write protected!) CAUTION: The meter EEPROM parameters were set on the factory to keep best performance. Do not change EEPROM parameters unless instructed by factory technical support representative!	22	MW	115 to 285 (EEPROM Memory Table Index) NOTE: EEPROM indexes 0-114 are read only!	<Value>		Command: MW,XXX,<Value> where: XXX= EEPROM Table Index Reply: Example: MW,101,3

UART Error Codes:

- 1 - Not Supported Command or Back Door is not enabled.
- 2 - Wrong # of Arguments.
- 3 - Address is Out of Range (MR or MW commands).
- 4 - Wrong # of the characters in the Argument.
- 5 - Attempt to Alter Write Protected Area in the EEPROM.
- 6 - Proper Command or Argument is not found.
- 7 - Wrong value of the Argument.
- 8 - Not Permitted Command (see operating manual)
- 9 - Manufacture specific info EE access KEY (wrong key or key is disabled).

Alarm Events codes and bit position:

Code	Event Description	Bit position
0	High Flow Alarm	0x0001
1	Low Flow Alarm	0x0002
2	Range between H-L	0x0004
3	Totalizer#1 > Limit	0x0008
4	Totalizer#2 > Limit	0x0010
5	Pulse Output Queue > Limit	0x0020
6	Flow Above Limit	0x0040
7	Password Event	0x0080
8	Power on Event	0x0100

Diagnostic Events codes and bit position:

Code	Event Description	Bit position
0	CPU Temperature too High	0x0001
1	Sensor Compartment Temp too High	0x0002
2	Sensor Heater voltage out of range	0x0004
3	Sensor RTD voltage out of range	0x0008
4	ADC 2.5 Vdc reference out of range	0x0010
5	Analog Output Interface Alarm	0x0020
6	Serial Communication Interface ERROR	0x0040
7	ModBus Communication Interface ERROR	0x0080
8	EEPROM ERROR	0x0100
9	Meter AUTO ZERO FAILURE	0x0200
A	Fatal Error	0x0400

11. TROUBLESHOOTING

11.1 Common Conditions

Your ZFM Digital Mass Flow Meter was thoroughly checked at numerous quality control points during and after manufacturing and assembly operations. It was calibrated according to your desired flow and pressure conditions for a given gas or a mixture of gases.

It was carefully packed to prevent damage during shipment. Should you feel that the instrument is not functioning properly, please check for the following common conditions first:

Are all cables connected correctly? Are there any leaks in the installation? Is the power supply correctly selected according to requirements? When several meters are used a power supply with appropriate current rating should be selected. Were the connector pinouts matched properly? When interchanging with other manufacturers' equipment, cables and connectors must be carefully wired for correct pin configurations. Is the pressure differential across the instrument sufficient?

11.2 Troubleshooting Guide

NO.	INDICATION	LIKELY REASON	SOLUTION
1	No zero reading after 15 min. warm up time and no flow condition.	Embedded temperature has been changed.	Perform Auto Zero Procedure (see section 6.4.12 "Sensor Zero Calibration").
2	Status LED indicator and OLED Display remains blank when unit is powered up. No response when flow is introduced from analog outputs 0-5 Vdc or 4-20 mA.	Power supply is bad or polarity is reversed.	Measure voltage on pins 4(+) and 5(-) of the 9 pin D-connector. If voltage is out of specified range, then replace power supply with a new one. If polarity is reversed (reading is negative) make correct connection.
		PC board is defective.	Return ZFM to factory for repair.
3	OLED Display reading or /and analog output 0-5Vdc signal fluctuate in wide range during flow measurement.	Output 0-5 Vdc signal (pins 2-3 of the D-connector) is shorted on the GND or overloaded.	Check external connections to pin 2 – 3, of the D-connector. Make sure the load resistance is more than 3000 Ohm.
4	OLED Display reading does correspond to the correct flow range, but 0-5 Vdc output signal does not change (always the same reading or around zero).	Output 0-5Vdc schematic is burned out or damaged.	Return ZFM to factory for repair.
		Analog flow output scale and offset variable are corrupted.	Restore original EEPROM scale and offset variable or perform analog output recalibration (see section 6.4.11.5).
5	OLED Display reading and 0-5 Vdc output voltage do correspond to the correct flow range, but 4-20 mA output signal does not change (always the same or reading around 4.0 mA).	External loop is open or load resistance more than 550 Ohm.	Check external connections to pins 2 and 6 of the D-connector. Make sure the loop resistance is less than 550 Ohm.
		Output 4-20 mA schematic is burned out or damaged.	Return ZFM to factory for repair.
6	Calibration is off (more than ± 1.0 % F.S.).	ZFM has initial zero shift.	Shut off the flow of gas into the ZFM ensure gas source is disconnected and no seepage or leak occurs into the meter). Wait for 15 min. with no flow condition and perform Auto Zero calibration Procedure (see section 6.4.12 "Zero Calibration").
7	OLED reading is above maximum flow range and output voltage 0-5 Vdc signal is more than 5.0 Vdc when gas flows through the ZFM.	Sensor under swamping conditions (flow is more than 10% above maximum flow rate for particular ZFM).	Lower the flow through ZFM within calibrated range or shut down the flow completely. The swamping condition will end automatically.
		PC board or sensor is defective.	Return ZFM to factory for repair.

NO.	INDICATION	LIKELY REASON	SOLUTION
8	Gas flows through the ZFM, but OLED Display reading and the output voltage 0-5 Vdc signal do not respond to flow.	The gas flow is too low for particular model of ZFM.	Check maximum flow range on transducer's front panel and make required flow adjustment.
		Wrong or not calibrated gas table/ K-Factor is selected.	Select proper Gas Table. Disable KFactor.
		Sensor or PC board is defective.	Return ZFM to factory for repair.
9	Gas does not flow through the ZFM with inlet pressure applied to the inlet fitting. OLED Display reading and output voltage 0-5 Vdc signal show zero flow.	Filter screen obstructed at inlet.	Flush clean or disassemble to remove impediments or replace the filter screen (see section 7.2.1). NOTE: Calibration accuracy can be affected.
10	Gas flows through the ZFM, output voltage 0-5 Vdc signal does not respond to flow (reading near 1mV). OLED Display reading is negative.	Direction of the gas flow is reversed.	Check the direction of gas flow as indicated by the arrow on the front of the meter and make required reconnection in the installation.
		ZFM is connected in the installation with back pressure conditions and gas leak exist in the system.	Locate and correct gas leak in the system. If ZFM has internal leak return it to factory for repair.
11	The Diagnostic events code 2 or 3 are active	Sensor temperature is too low or too high.	Make sure the ambient and gas temperatures are within specified range (above 0 and below 50°C).
12	The Diagnostic event code 0 is active	CPU temperature is too high (overload).	Disconnect power from the ZFM. Make sure the ambient temperature is within specified range (below 50°C). Let the device cool down for at least 15 minutes. Apply power to the ZFM and check DE #0 status. If DE with code #0 is active again the unit has to be returned to the factory for repair.
13	The Status LED indicator is constantly on with the RED light.	Fatal Error (EEPROM or Auto Zero error).	Cycle the power on the ZFM. If Status LED still constantly on with RED light, wait 6 minutes and start Auto Zero function (see 6.4.12 Zero Calibration). If after Zero Calibration the Fatal Error condition will be indicated again the unit has to be returned to the factory for repair.
14	OLED Displays flow reading (analog output reading is correct) but main communication interface does not work.	Wrong host PC interface, or wiring connection	Make sure interface type (RS232 or RS485) on the host PC is the same as on ZFM device. If required, use RS232 to RS485 converter. Check communication wiring connection according to Paragraph 3.3
		ZFM has RS485 interface, but device address does not match to address used by host PC.	Change ZFM RS485 address to be matched to host PC software settings (see Paragraph 6.4.11.2).

11.3 Technical Assistance

Aalborg® Instruments will provide technical assistance over the phone to qualified repair personnel. Please call our Technical Assistance at 845-770-3000. Please have your Serial Number and Model Number ready when you call.

12. CALIBRATION CONVERSIONS FROM REFERENCE GASES

The calibration conversion incorporates the K factor. The K factor is derived from gas density and coefficient of specific heat. For diatomic gases:

$$K_{\text{gas}} = \frac{1}{d \times C_p}$$

where d = gas density (gram/liter)
Cp = coefficient of specific heat (cal/gram)

Note in the above relationship that d and Cp are usually chosen at the same conditions (standard, normal or other).

If the flow range of a Mass Flow Meter remains unchanged, a relative K factor is used to relate the calibration of the actual gas to the reference gas.

$$K = \frac{Q_a}{Q_r} = \frac{K_a}{K_r}$$

where Q_a = mass flow rate of an actual gas (sccm)
Q_r = mass flow rate of a reference gas (sccm)
K_a = K factor of an actual gas
K_r = K factor of a reference gas

For example, if we want to know the flow rate of oxygen and wish to calibrate with nitrogen at 1000 SCCM, the flow rate of oxygen is:

$$Q_{O_2} = Q_a = Q_r \times K = 1000 \times 0.9926 = 992.6 \text{ sccm}$$

where K = relative K factor to reference gas (oxygen to nitrogen)



NOTE: If particular K factor is activated via digital interface, the user does not need to perform any conversion. All conversion computations will be performed internally by CPU.

APPENDIX I INTERNAL "K" FACTORS



CAUTION: K-Factors at best are only an approximation. K factors should not be used in applications that require accuracy better than +/- 5 to 10%.

Index	ACTUAL GAS NAME	FORMULA	K Factor Relative to N2	Cp [Cal/g]	STD Density [g/l]
1	Acetylene	C2H2	0.5829	0.4036	1.0818
2	Ammonia	NH3	0.7310	0.492	0.7076
3	Arsine	AsH3	0.6735	0.1167	3.2380
4	Boron Trifluoride	BF3	0.5082	0.1778	2.8163
5	Bromine	Br2	0.8083	0.0539	6.6380
6	Butane	C4H10	0.2631	0.4007	2.4141
7	Carbon Monoxide	CO	1.0000	0.2488	1.1637
8	Cyanogen	C2N2	0.6100	0.2613	2.1618
9	Chlorine	Cl2	0.8600	0.114	2.9447
10	Carbonyl Fluoride	COF2	0.5428	0.1710	2.7418
11	Carbonyl Sulfide	COS	0.6606	0.1651	2.4951
12	Carbon Disulfide	CS2	0.6026	0.1428	3.1626
13	Ethane	C2H6	0.5000	0.420	1.2494
14	Ethylene	C2H4	0.6000	0.365	1.1647
15	Fluorine	F2	0.9784	0.1873	1.5780
16	Hydrogen	H2	1.0106	3.419	0.0837
17	Hydrogen Chloride	HCl	1.0000	0.1912	1.5147
18	Methane	CH4	0.7175	0.5328	0.6656
19	Nitrous Oxide	N2O	0.7128	0.2088	1.8284
20	Neon	Ne	1.4600	0.246	0.8379
21	Nitric Oxide	NO	0.9900	0.2328	1.2466
22	Phosphine	PH3	0.7590	0.2374	1.4123
23	Propane	C3H8	0.3500	0.399	1.8313
24	Propylene	C3H6	0.4000	0.366	1.7475
25	Sulfur Dioxide	SO2	0.6900	0.1488	2.6608
26	Xenon	Xe	1.4400	0.0378	5.4538
27	User Defined				

APPENDIX II GAS FACTOR TABLE (“K FACTORS”)



CAUTION: K-Factors at best are only an approximation. K factors should not be used in applications that require accuracy better than +/- 5 to 10%.

INDEX	ACTUAL GAS	K Factor Relative to N ₂	Cp [Cal/g]	DENSITY [g/l]
0	Acetylene C ₂ H ₂	0.5829	.4036	1.162
1	Air	1.000	0.24	1.293
2	Allene (Propadiene) C ₃ H ₄	0.4346	0.352	1.787
3	Ammonia NH ₃	.7310	.492	.760
4	Argon Ar	1.4573	.1244	1.782
5	Arsine AsH ₃	0.6735	0.1167	3.478
6	Boron Trichloride BCl ₃	0.4089	0.1279	5.227
7	Boron Trifluoride BF ₃	0.5082	0.1778	3.025
8	Bromine Br ₂	0.8083	0.0539	7.130
9	Boron Tribromide Br ₃	0.38	0.0647	11.18
10	Bromine Pentafluoride BrF ₅	0.26	0.1369	7.803
11	Bromine Trifluoride BrF ₃	0.3855	0.1161	6.108
12	Bromotrifluoromethane CBrF ₃	0.3697	0.1113	6.644
13	1,3-Butadiene C ₄ H ₆	0.3224	0.3514	2.413
14	Butane C ₄ H ₁₀	.2631	.4007	2.593
15	1-Butane C ₄ H ₈	0.2994	0.3648	2.503
16	2-Butane C ₄ H ₈ CIS	0.324	0.336	2.503
17	2-Butane C ₄ H ₈ TRANS	0.291	0.374	2.503
18	Carbon Dioxide CO ₂	.7382	.2016	1.964
19	Carbon Disulfide CS ₂	0.6026	0.1428	3.397
20	Carbon Monoxide C ₀	1.00	.2488	1.250
21	Carbon Tetrachloride CCl ₄	0.31	0.1655	6.860
22	Carbon Tetrafluoride (Freon-14) CF ₄	0.42	0.1654	3.926
23	Carbonyl Fluoride COF ₂	0.5428	0.1710	2.945
24	Carbonyl Sulfide COS	0.6606	0.1651	2.680
25	Chlorine Cl ₂	0.86	0.114	3.163
26	Chlorine Trifluoride ClF ₃	0.4016	0.1650	4.125
27	Chlorodifluoromethane (Freon-22) CHClF ₂	0.4589	0.1544	5.326
28	Chloroform CHCl ₃	0.3912	0.1309	5.326
29	Chloropentafluoroethane (Freon -115) C ₂ ClF ₅	0.2418	0.164	6.892
30	Chlorotrifluoromethane (Freon-13) CClF ₃	0.3834	0.153	4.660
31	Cyanogen C ₂ N ₂	0.61	0.2613	3.322
32	Helium He	1.454	1.241	.1786
33	Hydrogen H ₂	1.0106	3.419	.0899
34	Hydrogen H ₂ (> 100 L/min)	1.92	3.419	0.0899
35	Oxygen O ₂	0.9926	0.2193	1.427

ACTUAL GAS	K FACTOR Relative to N ₂	Cp [Cal/g]	Density (@ 0°C) [g/l]
Deuterium D ₂	1.00	1.722	1.799
Diborane B ₂ H ₆	.4357	.508	1.235
Dibromodifluoromethane CBr ₂ F ₂	.1947	.15	9.362
Dichlorodifluoromethane (Freon-12) CCl ₂ F ₂	.3538	.1432	5.395
Dichlorofluoromethane (Freon-21) CHCl ₂ F	.4252	.140	4.592
Dichloromethylsilane (CH ₃) ₂ SiCl ₂	.2522	.1882	5.758
Dichlorosilane SiH ₂ Cl ₂	.4044	.150	4.506
Dichlorotetrafluoroethane (Freon-114) C ₂ Cl ₂ F ₄	.2235	.1604	7.626
1,1-Difluoroethylene (Freon-1132A) C ₂ H ₂ F ₂	.4271	.224	2.857
Dimethylamine (CH ₃) ₂ NH	.3714	.366	2.011
Dimethyl Ether (CH ₃) ₂ O	.3896	.3414	2.055
2,2-Dimethylpropane C ₃ H ₁₂	.2170	.3914	3.219
Ethane C ₂ H ₆	.50	.420	1.342
Ethanol C ₂ H ₆ O	.3918	.3395	2.055
Ethyl Acetylene C ₄ H ₆	.3225	.3513	2.413
Ethyl Chloride C ₂ H ₅ Cl	.3891	.244	2.879
Ethylene C ₂ H ₄	.60	.365	1.251
Ethylene Oxide C ₂ H ₄ O	.5191	.268	1.965
Fluorine F ₂	.9784	.1873	1.695
Fluoroform (Freon-23) CHF ₃	.4967	.176	3.127
Freon-11 CCl ₃ F	.3287	.1357	6.129
Freon-12 CCl ₂ F ₂	.3538	.1432	5.395
Freon-13 CClF ₃	.3834	.153	4.660
Freon-13B1 CBrF ₃	.3697	.1113	6.644
Freon-14 CF ₄	.4210	.1654	3.926
Freon-21 CHCl ₂ F	.4252	.140	4.592
Freon-22 CHClF ₂	.4589	.1544	3.858
Freon-113 CCl ₂ CClF ₂	.2031	.161	8.360
Freon-114 C ₂ Cl ₂ F ₄	.2240	.160	7.626
Freon-115 C ₂ ClF ₅	.2418	.164	6.892
Freon-C318 C ₄ F ₈	.1760	.185	8.397
Germane GeH ₄	.5696	.1404	3.418
Germanium Tetrachloride GeCl ₄	.2668	.1071	9.565
Helium He (= <10 L/min)	1.454	1.241	.1786
Helium He-1 (>50 L/min)	2.43	1.241	.1786
Helium He-2 (>10-50 L/min)	2.05	1.241	.1786
Hexafluoroethane C ₂ F ₆ (Freon-116)	.2421	.1834	6.157
Hexane C ₆ H ₁₄	.1792	.3968	3.845
Hydrogen H ₂ -1 (= <10 L/min)	1.0106	3.419	.0899
Hydrogen H ₂ -2 (>10-100 L)	1.35	3.419	.0899
Hydrogen H ₂ -3 (>100 L)	1.9	3.419	.0899

ACTUAL GAS	K FACTOR Relative to N ₂	Cp [Cal/g]	Density (@ 0°C) [g/l]
Hydrogen Bromide HBr	1.000	.0861	3.610
Hydrogen Chloride HCl	1.000	.1912	1.627
Hydrogen Cyanide HCN	.764	.3171	1.206
Hydrogen Fluoride HF	.9998	.3479	.893
Hydrogen Iodide HI	.9987	.0545	5.707
Hydrogen Selenide H ₂ Se	.7893	.1025	3.613
Hydrogen Sulfide H ₂ S	.80	.2397	1.520
Iodine Pentafluoride IF ₅	.2492	.1108	9.90
Isobutane CH(CH ₃) ₃	.27	.3872	3.593
Isobutylene C ₄ H ₈	.2951	.3701	2.503
Krypton Kr	1.453	.0593	3.739
Methane CH ₄ (<=10 L/min)	.7175	.5328	.715
Methane CH ₄ -1 (>=10 L/min)	.75	.5328	.715
Methanol CH ₃	.5843	.3274	1.429
Methyl Acetylene C ₃ H ₄	.4313	.3547	1.787
Methyl Bromide CH ₂ Br	.5835	.1106	4.236
Methyl Chloride CH ₃ Cl	.6299	.1926	2.253
Methyl Fluoride CH ₃ F	.68	.3221	1.518
Methyl Mercaptan CH ₃ SH	.5180	.2459	2.146
Methyl Trichlorosilane (CH ₃)SiCl ₃	.2499	.164	6.669
Molybdenum Hexafluoride MoF ₆	.2126	.1373	9.366
Monoethylamine C ₂ H ₅ NH ₂	.3512	.387	2.011
Monomethylamine CH ₃ NH ₂	.51	.4343	1.386
Neon NE	1.46	.246	.900
Nitric Oxide NO	.990	.2328	1.339
Nitrogen N ₂	1.000	.2485	1.25
Nitrogen Dioxide NO ₂	.737	.1933	2.052
Nitrogen Trifluoride NF ₃	.4802	.1797	3.168
Nitrosyl Chloride NOCl	.6134	.1632	2.920
Nitrous Oxide N ₂ O	.7128	.2088	1.964
Octafluorocyclobutane (Freon-C318) C ₄ F ₈	.176	.185	8.397
Oxygen O ₂	.9926	.2193	1.427
Oxygen Difluoride OF ₂	.6337	.1917	2.406
Ozone	.446	.195	2.144
Pentaborane B ₅ H ₉	.2554	.38	2.816
Pentane C ₅ H ₁₂	.2134	.398	3.219
Perchloryl Fluoride ClO ₃ F	.3950	.1514	4.571
Perfluoropropane C ₃ F ₈	.174	.197	8.388
Phosgene COCl ₂	.4438	.1394	4.418
Phosphine PH ₃	.759	.2374	1.517

ACTUAL GAS	K FACTOR Relative to N ₂	Cp [Cal/g]	Density (@ 0°C) [g/l]
Phosphorous Oxychloride POCl ₃	.36	.1324	6.843
Phosphorous Pentafluoride PH ₅	.3021	.1610	5.620
Phosphorous Trichloride PCl ₃	.30	.1250	6.127
Propane C ₃ H ₈	.35	.399	1.967
Propylene C ₃ H ₆	.40	.366	1.877
Silane SiH ₄	.5982	.3189	1.433
Silicon Tetrachloride SiCl ₄	.284	.1270	7.580
Silicon Tetrafluoride SiF ₄	.3482	.1691	4.643
Sulfur Dioxide SO ₂	.69	.1488	2.858
Sulfur Hexafluoride SF ₆	.2635	.1592	6.516
Sulfuryl Fluoride SO ₂ F ₂	.3883	.1543	4.562
Tetrafluoroethane (Forane 134A) CF ₃ CH ₂ F	.5096	.127	4.224
Tetrafluorohydrazine N ₂ F ₄	.3237	.182	4.64
Trichlorofluoromethane (Freon-11) CCl ₃ F	.3287	.1357	6.129
Trichlorosilane SiHCl ₃	.3278	.1380	6.043
1,1,2-Trichloro-1,2,2 Trifluoroethane (Freon-113) CCl ₂ CClF ₂	.2031	.161	8.36
Triisobutyl Aluminum (C ₄ H ₉) ₃ AL	.0608	.508	8.848
Titanium Tetrachloride TiCl ₄	.2691	.120	8.465
Trichloro Ethylene C ₂ HCl ₃	.32	.163	5.95
Trimethylamine (CH ₃) ₃ N	.2792	.3710	2.639
Tungsten Hexafluoride WF ₆	.2541	.0810	13.28
Uranium Hexafluoride UF ₆	.1961	.0888	15.70
Vinyl Bromide CH ₂ CHBr	.4616	.1241	4.772
Vinyl Chloride CH ₂ CHCl	.48	.12054	2.788
Xenon Xe	1.44	.0378	5.858

APPENDIX III COMPONENT DIAGRAM

TOP COMPONENT SIDE

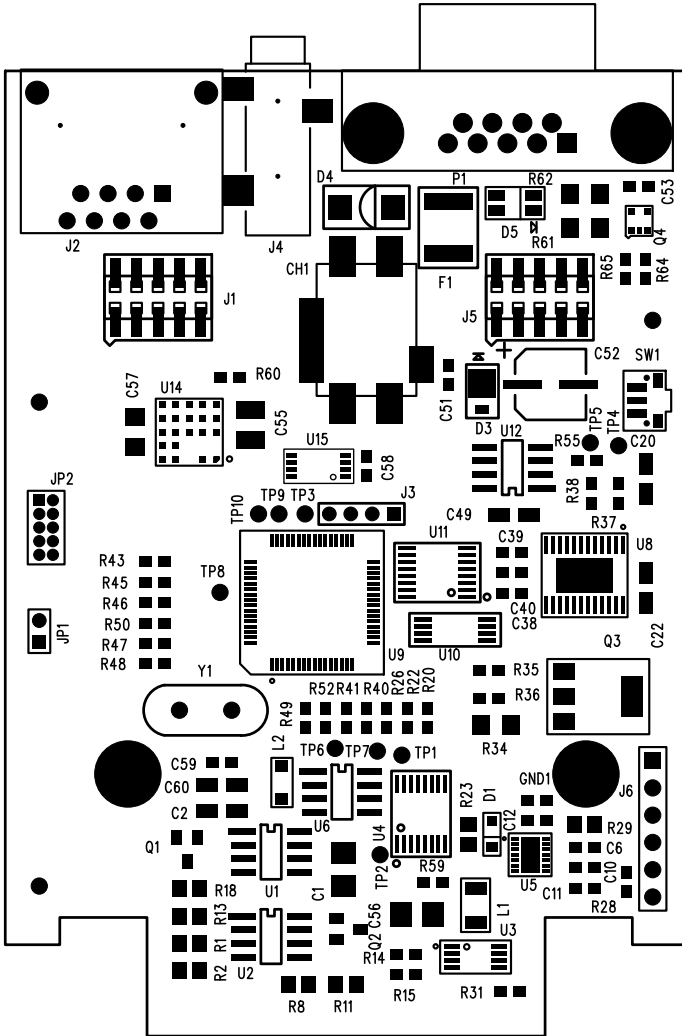

BOTTOM COMPONENT SIDE

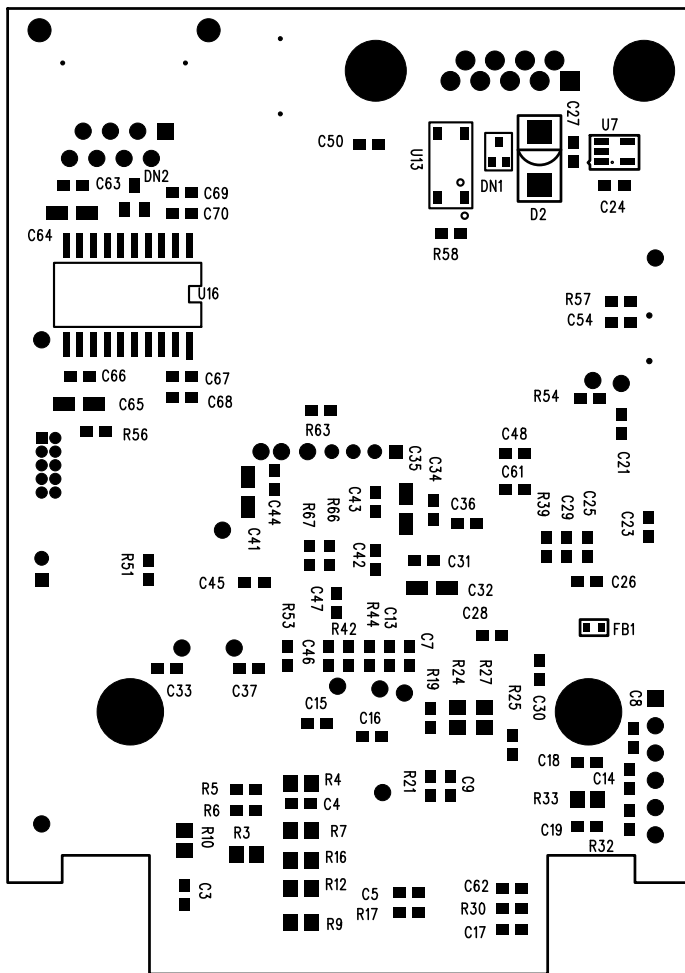

APPENDIX IV

DIMENSIONAL DRAWINGS

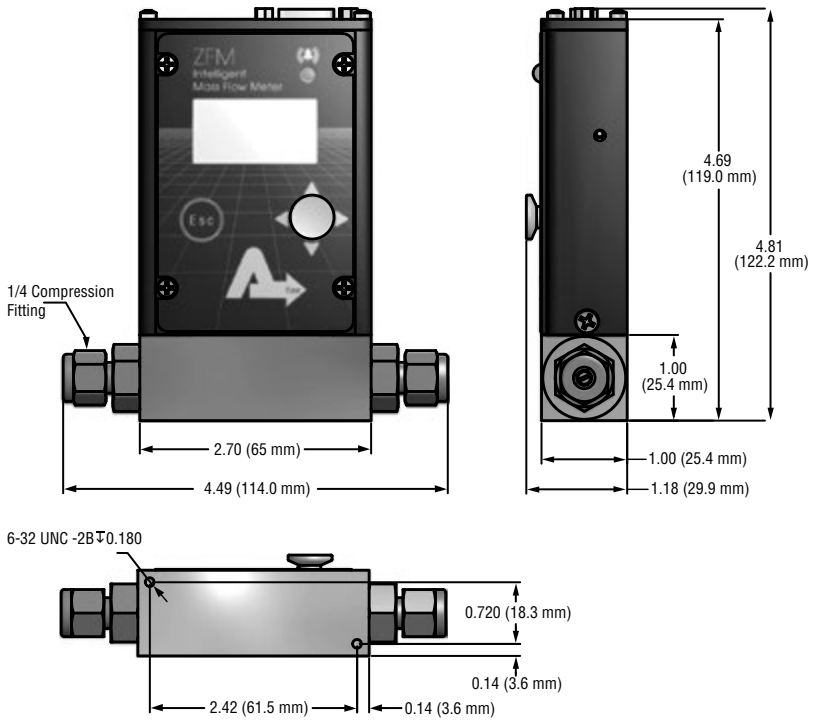

NOTE: Aalborg® reserves the right to change designs and dimensions at its sole discretion at any time without notice. For certified dimensions please contact Aalborg®.

APPENDIX

WARRANTY

Aalborg® Mass Flow Systems are warranted against parts and workmanship for a period of one year from the date of purchase. Calibrations are warranted for up to six months after date of purchase, provided calibration seals have not been tampered with. It is assumed that equipment selected by the customer is constructed of materials compatible with gases used. Proper selection is the responsibility of the customer. It is understood that gases under pressure present inherent hazards to the user and to equipment, and it is deemed the responsibility of the customer that only operators with basic knowledge of the equipment and its limitations are permitted to control and operate the equipment covered by this warranty. Anything to the contrary will automatically void the liability of Aalborg® and the provisions of this warranty. Defective products will be repaired or replaced solely at the discretion of Aalborg® at no charge. Shipping charges are borne by the customer. This warranty is void if the equipment is damaged by accident or misuse, or has been repaired or modified by anyone other than Aalborg® or factory authorized service facility. This warranty defines the obligation of Aalborg® and no other warranties expressed or implied are recognized.

NOTE: Follow Return Procedures In Section 1.3.

Products Manufactured By Aalborg

ROTAMETERS

Single Tube

Aluminum / Brass / Stainless • Interchangeable Glass Flow Tubes • Optional Valves

Multiple Tube

Two to Six Channels • Aluminum or Stainless

PTFE Single and Multiple Tube

Chemically Inert • 1 to 4 Channels • Interchangeable Glass Flow tubes

PTFE - PFA

Chemically Inert • Low to Medium Flow of Corrosive Liquids with PFA Flow Tube

Kits

Aluminum / Stainless / PTFE • Including Five Glass Flow Tubes and a Set of Floats

Gas Proportioners

Aluminum / Stainless • Used for Blending Two or Three Gases

Medium Range

Glass Safety Shield • Dual Air and Water Scale

Optical Sensor Switch

Non-Invasive Means for Detection of a High or Low Flow

High Flow Industrial Stainless Steel Flow Meters

Heavy Duty Stainless Steel • Direct Reading Air and Water Scales

VALVES

Barstock

Brass or Stainless • Standard or High Precision

PTFE

Chemically Inert • Needle or Metering

Proportionating Solenoid

Stainless • For Controlling Gas or Liquid Flow

• Pulse width Modulated

SMV • Stepping Motor Valve

PERISTALTIC PUMPS

Fixed RPM Pumps

Pump Heads

Tubing Pumps

Variable Speeds

Dispensing Pumps

Flexible Tubings

ELECTRONIC METERS & CONTROLLERS

Low Cost Mass Flow Meters

Aluminum or Stainless • With or Without LCD Readout

Low Cost Mass Flow Controllers

Aluminum or Stainless • With or Without LCD Readout

Mass Flow Controllers

Stainless • One to Four Channel Systems

Digital Mass Flow Controllers

Auto Zero • Totalizer • Alarms = Built in RS485

Multi-Parameter Digital Mass Flow Meters

Displays Flow Pressure and Temperature

Paddle Wheel Meters

For Liquids • Optional Temperature Measurements

Vortex In-Line and Insertion Flow Meters

Steam / Liquid and Gas Service

Smart Rate / Totalizer / Signal Conditioner

LCD Keypad • RS232 / 485 • Pulse Output • Alarms